

PROFINET®

Connection solutions for industrial networks



Bem-vindo

Добро пожаловать

Witamy

Varmt välkommen

欢迎光临 **Vítáme vás**

Hoş geldiniz

Herzlich willkommen

Ласкаво просимо

환영합니다 **Bienvenue**

Hartelijk welkom

Welcome

Bienvenidos

Bine ați venit

Benvenuti

Welcome

To contact your local Lapp Group representative please visit www.lappgroup.com/worldwide

Table of contents

Informations about the company

Brand quality from Stuttgart	2
Reliably connecting the world	3
Product finder – don't search, find it!	4

Industrial Ethernet

INTRODUCTION	
What is Industrial Ethernet?	6
THE LAPP RANGE	
Your solution provider for PROFINET® cabling and connection	8
CABLE EXPERTISE	
General information on the selection criteria and measures for proper application of cables and wires	10

Copper cables in focus

INTRODUCTION	
Industrial cabling with copper data cables	14
CABLE EXPERTISE	
General information on PROFINET®/ type specification according to the PROFINET® guideline	15
OVERVIEW/FINDER	
The complete range: sensor/actuator cabling	16
2-pair copper conductor	17
4-pair copper conductor	20
Copper connectors	24
Installation instructions	26
Assembly selection overview	28
Connector finder	30

Fibre optic cables in focus

INTRODUCTION	
Fibre optic cables	33
CABLE EXPERTISE	
PROFINET® transmission via fibre optic cables	34
Different fibre optic cables in the PROFINET® range	35
THE LAPP RANGE	
PROFINET® fibre optic cables	36
CONNECTOR EXPERTISE	
Fibre optic connectors for PROFINET® applications according to PNO	38
THE LAPP RANGE	
PROFINET® fibre optic connectors for on-site assembly	40
Assembly sets for PROFINET® fibre optic connectors	41
OVERVIEW/FINDER	
Connector/cable finder	42

Appendix

ADDITIONAL MATERIAL	
Manufacturer's declaration and PROFIBUS and PROFINET® User Organization (PNO)	44



Brand quality from Stuttgart



ÖLFLEX® Power and control cables

ÖLFLEX® has become synonymous with power and control cables. Our flexible and oil-resistant cables satisfy the highest demands and can withstand even the very toughest conditions.



EPIC® Industrial connectors

EPIC® industrial connectors can be found everywhere in industrial machinery and plant engineering, for measuring, control and drives. EPIC® is a flexible system of housings, inserts and contacts: all extremely robust, absolutely safe and simplicity itself to assemble.



UNITRONIC® Data communication systems

Our high-quality UNITRONIC® data network cables and field bus components provide a forward-looking solution for all applications in industrial machinery and plant engineering. From transmission of simple control signals to field bus signals in complex network structures – we offer a dependable cabling and connection solution for almost every situation.



SKINTOP® Cable glands

Simply feed in the cable and twist. That's it. Our SKINTOP® cable glands provide secure connections in no time. The universal systems are simple but effective. They secure and centre the cable, hermetically seal it and guarantee optimum strain relief.



ETHERLINE® Data communication systems for ETHERNET technology

Our ETHERLINE® branded products open up a secure, fast and reliable path to the future of Ethernet applications. The systems are made up of durable and robust cables and connection components for passive network technology, and deliver an effective solution for almost any application, particularly in an industrial environment.



SILVYN® Protective cable conduit systems and cable carrier systems

The universal range of SILVYN® protection and guidance systems protect cables effectively against dust, moisture, mechanical, thermal and chemical influences. The versatile SILVYN® CHAIN range of energy supply chains also protects and guides cables in dynamic applications.



HITRONIC® Optical transmission systems

HITRONIC® fibre optic cables make transmitting large data volumes easy: fault free, bug proof and at almost light speed. Even electromagnetic radiation does not interfere with the transmission. The HITRONIC® range includes the ideal solution for indoor or outdoor use, for demanding conditions, and even for use in power chains.



FLEXIMARK® Marking systems

The requirement: Permanent marking. The solution: FLEXIMARK®. These sophisticated systems mean that a clear overview inside a control cabinet is no longer just a pipe dream. From simple labels for manual marking through to electronic markings, the FLEXIMARK® range is guaranteed to be permanent.

Reliably connecting the world

We want to help you become even more productive and successful. This is why we work tirelessly on optimising our processes. We do everything to make sure we always find the best solution for you and also provide you with quick, efficient and effective support.

No matter where you are – we are always by your side. Our plants, sales companies, partners and, above all, our competent teams of advisers ensure we offer you a comprehensive service on every continent. We do not simply distribute cable technology, we also

manufacture our products ourselves – which represents another advantage for you. As a manufacturer with 17 of our own production facilities, you will benefit from our expertise in the development, design and manufacture of cables, system products and cable accessories. Thanks to this expertise, we can guarantee that Lapp will provide you with the quality that you require and that you demand.

You can always rely on quality from Lapp – wherever you are in the world. This is also embodied by our strong brands.

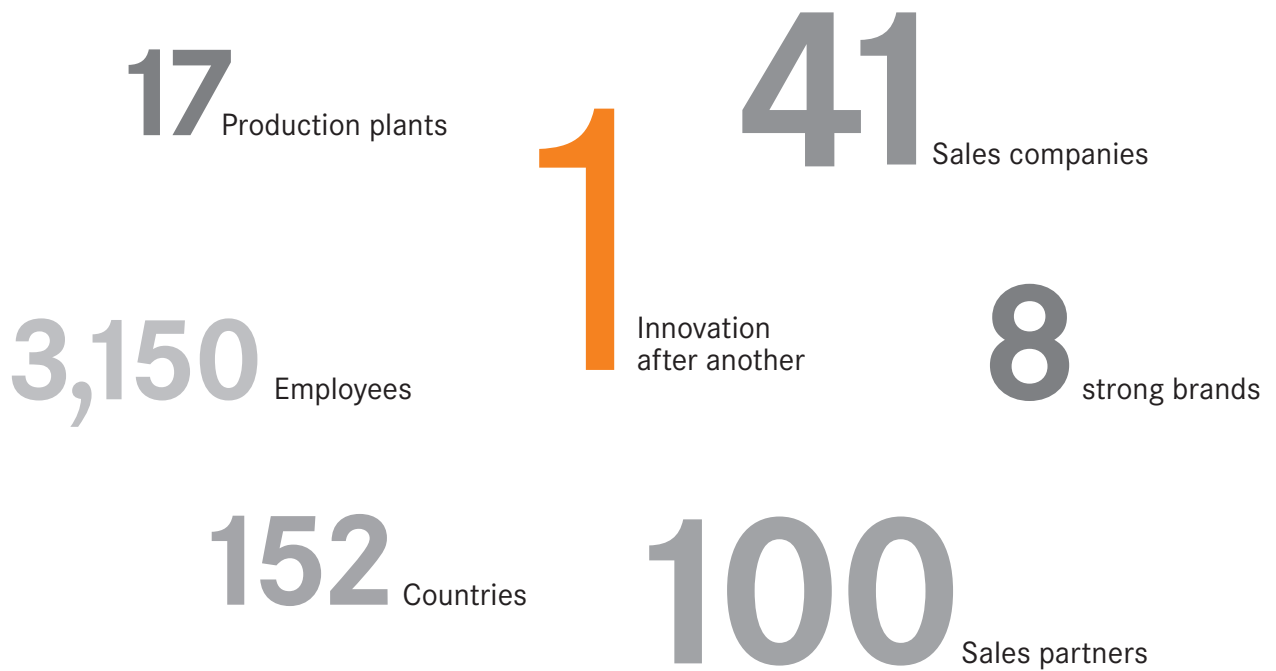

www.lappgroup.com/worldwide



Product finder – don't search, find it!

The Lapp Group not only offers you more than 40,000 articles, but also the quickest way to find the right cables, connectors and whatever else you need.

- Straightforward selection of the desired filter properties for quickly finding the product of your choice
- Possible to order immediately from the e-shop
- Fast interactive product finder

Simply use our product finder at
www.lappgroup.com/productfinder

Cable Assembly Finder

Based on criteria such as the number of pins, connector/female, sheath material and cable length, you are able to find the suitable cable assembly in a matter of moments from the following areas:

- UNITRONIC® Sensor/actuator
- ETHERLINE® Industrial Ethernet
- UNITRONIC® Fieldbus
- HITRONIC® Fibre optic cable

www.lappgroup.com/assemblyfinder

Cable Finder

Based on criteria such as the number of cores, cross-section in mm² and nominal voltage, it directs you to the correct article in seconds.

www.lappgroup.com/cablefinder

Cable Gland Finder

Use the SKINTOP® Finder to help you identify the cable gland you need and the required accessories. What's more, the online catalogue provides you with a direct route to your order or to more detailed product information.

www.lappgroup.com/cable-glandfinder

Connector Finder

Design, insert, housing and counterpart. These four selections take you to the appropriate connector in just a few clicks.

www.lappgroup.com/connectorfinder

Connector Housing Configurator

configure your own individual industrial connector housing with locking concept and cable entries.

www.lappgroup.com/connector-housing

Cable Marking Finder

Use our FLEXIMARK® Cable Marking Finder to quickly identify the appropriate marking and labelling for your application. You can also view the corresponding accessories and more detailed product information.

www.lappgroup.com/markfinder

Charging Cable Configurator

The Charging Cable Configurator enables you to find the cables and connectors you need to create the perfect charging cable in no time.

www.lappgroup.com/emobility-cablefinder

INDUSTRIAL ETHERNET

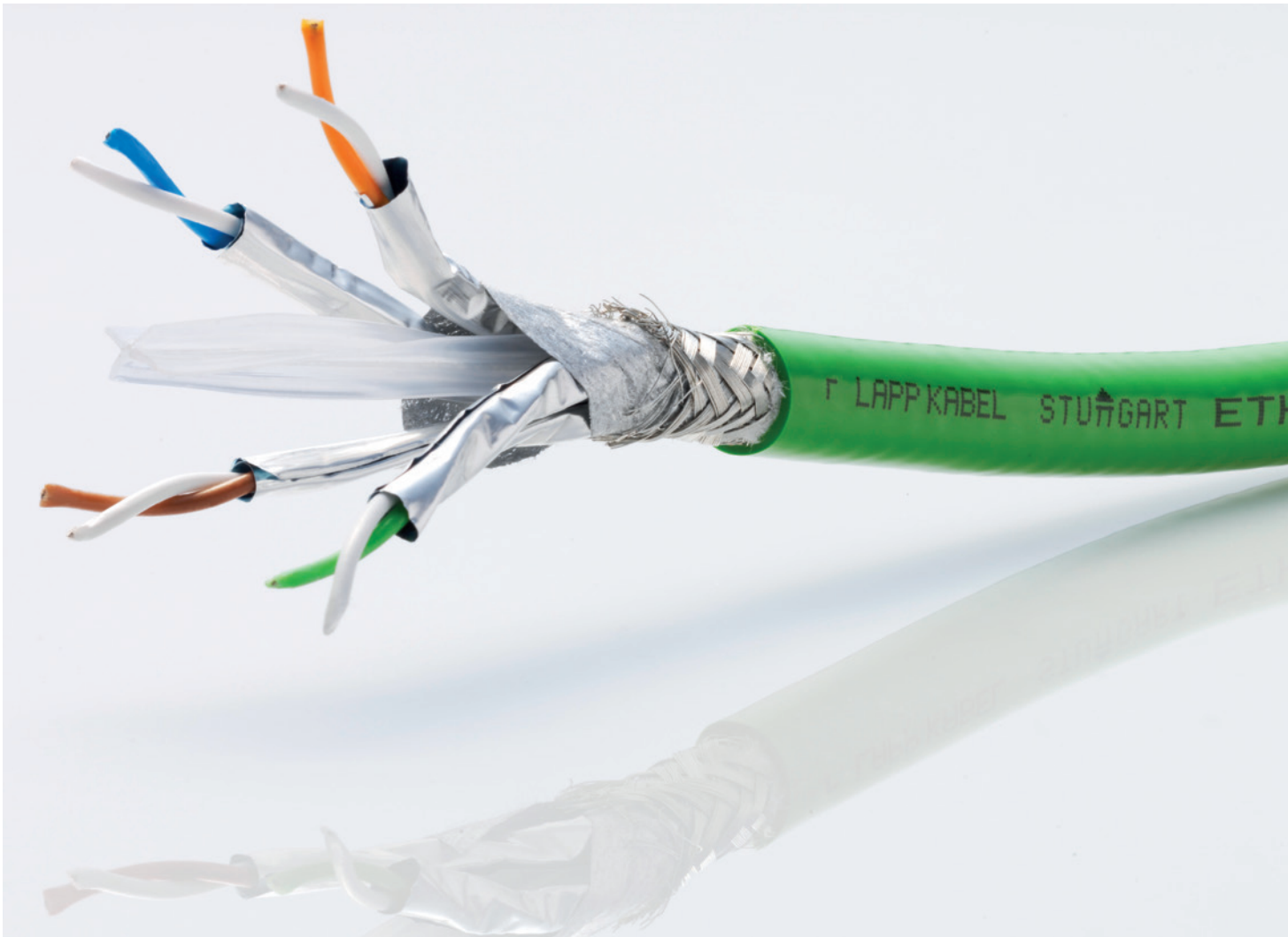

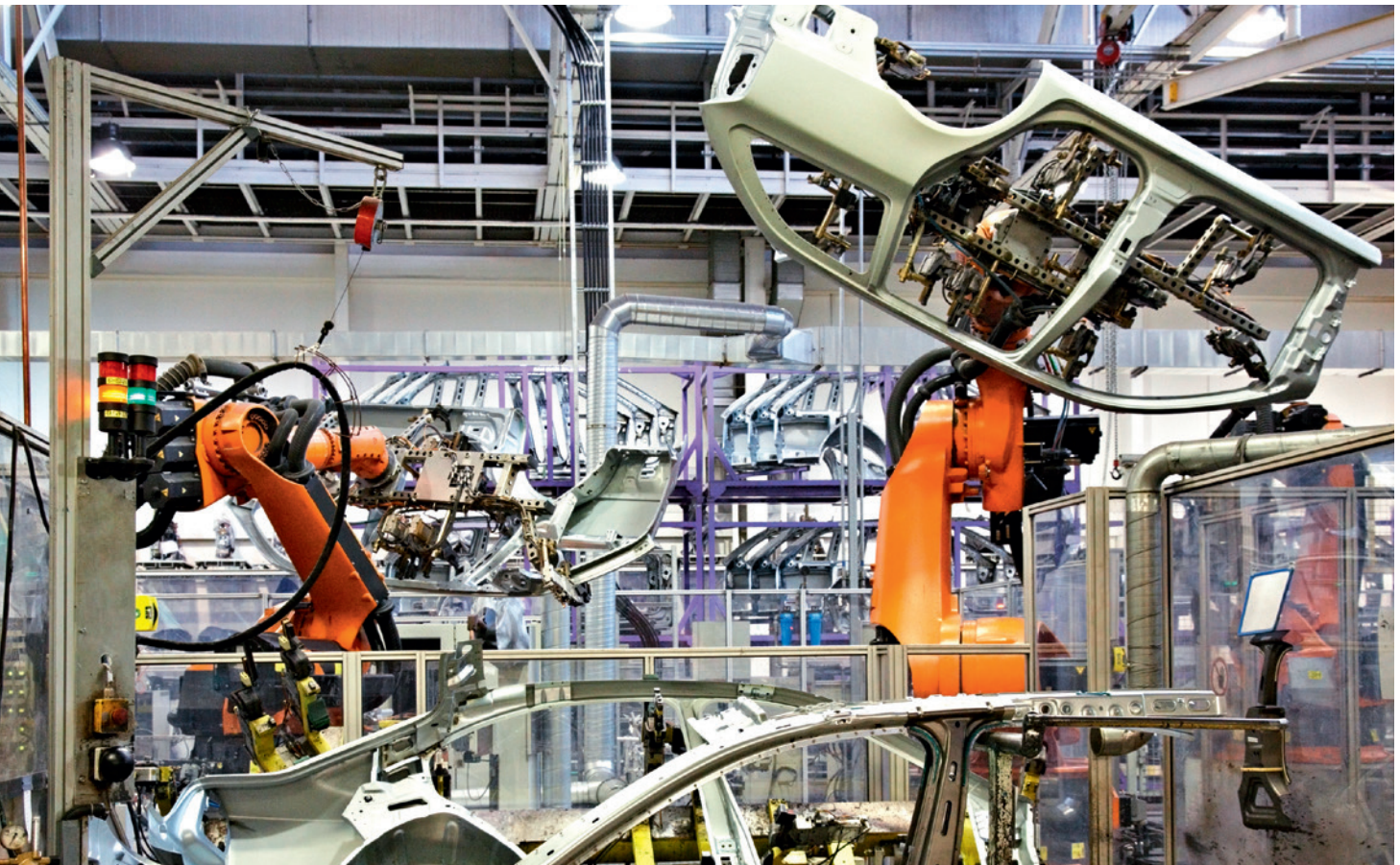

What is Industrial Ethernet?

The simple nature of the Ethernet standard makes it indispensable in company operations.

The reason for its acceptance and popularity lies not only in the continuous networking of a company but far more that it forms the basic technology for the largest network in the world, the Internet. The ETHERNET is the most commonly-used standard in the world.

The benefits of the Ethernet and the associated concept of networking are obvious:

- Use of IT innovations in the production environment
- Simple, flexible expansion options
- Standardised connection system with RJ45 or M12
- Dynamic bandwidth adjustment with 10/100 Mbit/s, 1 Gbit/s and up to 10 Gbit/s
- Continuous networking of the office, control and sensor/actuator level



All the information on the topic of PROFINET® at Lapp can be found here.
www.lappgroup.com/profinet

As a result of these advantages, more and more companies are also using the performance of the Ethernet to their benefit in their machinery and plant control as well as in production and process automation. With Industrial Ethernet, it is now possible to link the world of the office to the world of industry. This enables continuous communication with only a handful of interfaces and an almost unlimited number of participants in the network. Example applications include remote diagnostics via the Internet. Industrial Ethernet systems such as PROFINET® are special protocol variants and are ideally suited to use in industrial applications.

- Company-wide access and extensive availability of business intelligence
- Increased data rates available promptly for higher-speed information exchange
- Improved efficiency and speed of workflows and corresponding increase in energy efficiency and performance of the plants
- Continuous and coordinated monitoring and controlling of the plants for optimisation of production
- Wiring from the office area to the device level of the machinery
- Uniform cabling and connection standard from the office area to the device level of the machinery

A cross-level network such as Ethernet can offer further significant advantages over commercial fieldbus systems as a result of its usage and the components designed for industrial purposes. Here are a few examples:

For the purpose of physically connecting the Ethernet-supported components to one another, the user can choose between a twisted pair cable (TP), optical cables or wireless technology. The different transmission media generate differing maximum transmission length.

TRANSMISSION LENGTH DEPENDING ON THE MEDIUM

	Medium	Cables	Transmission length
ETHERNET	10 Base-T	Twisted pair	100 m
	10 Base-FL	62.5 µm, 50 µm multi-mode fibre optic cables	2,000 m
Fast ETHERNET	100 Base-TX	Twisted pair	100 m
	100 Base-FX	62.5 µm, 50 µm multi-mode fibre optic cables FDX	412 m
		62.5 µm, 50 µm multi-mode fibre optic cables HDX	2,000 m
Gigabit ETHERNET	1000 Base-CX	Twinax STP (150 Ω)	25 m
	1000 Base-T	Twisted pair	100 m
		62.5 µm multi-mode fibre optic cables	275 m
	1000 Base-SX 850 nm	50 µm multi-mode fibre optic cables	550 m
		62.5 µm multi-mode fibre optic cables	550 m
		50 µm multi-mode fibre optic cables	550 m
Single-mode fibre optic cables		5,000 m	
10 gigabit ETHERNET	10G Base-T	Twisted pair	100 m
	10G Base-LX4 WWDM	Single-mode fibre optic cables	10,000 m
	10G Base-LX4 WWDM	Multi-mode fibre optic cables	300 m
	10G Base-SR/SW 850 nm	62,5 µm multi-mode fibre optic cables	26 m
		50 µm multi-mode fibre optic cables	82 m
	10G Base-LR/LW 850 nm	Single-mode fibre optic cables	10,000 m
	10G Base-ER/EW 1550 nm	Single-mode fibre optic cables	40,000 m

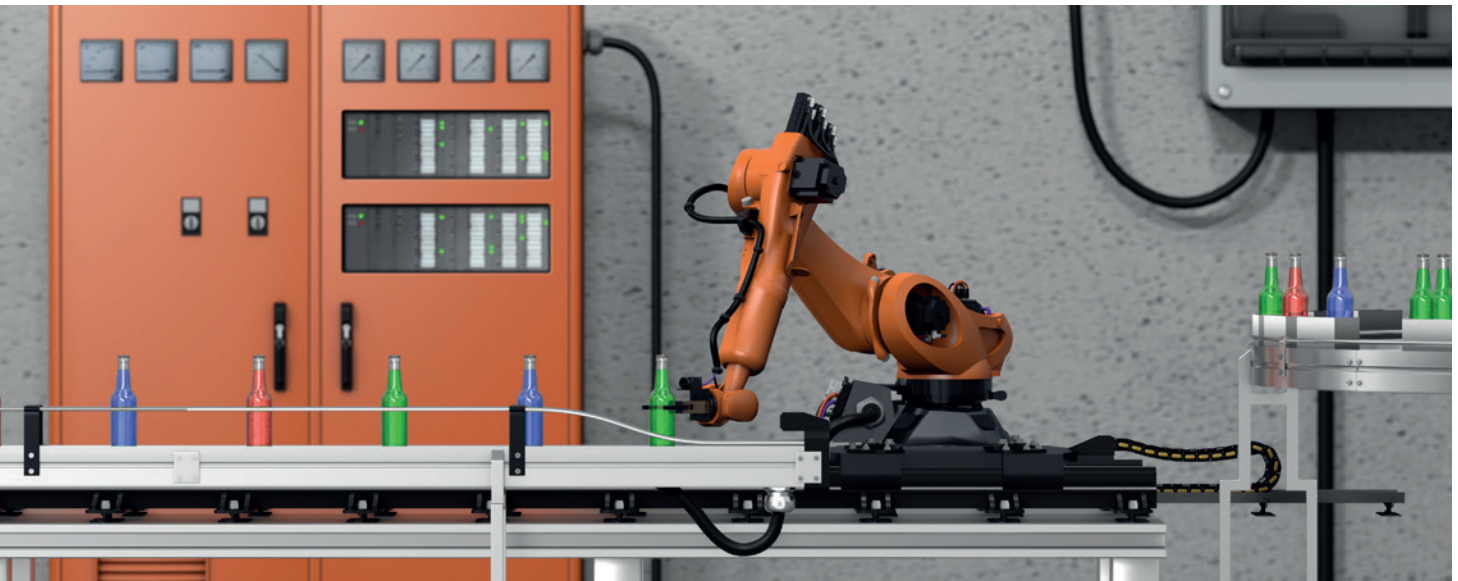

Watch the Lapp Group's
PROFINET® animation on YouTube.



Your solution provider for PROFINET® cabling and connection

You can rely on the continuous and high-quality overall system of cabling solutions from the Lapp Group to prevent failures, downtime and quality-related issues. A comprehensive range of standard and customised solutions are available here. Our wide range of PROFINET® cables for all uses are subject to precision testing at our test centre and laboratory. The Lapp range features true all-rounders for particularly demanding requirements relating to a diverse application range, flexibility (as required in applications featuring highly dynamic flexing with permanent bending and torsion), chemical and mechanical resistance, and approvals.

From 4-core or 8-core PROFINET® cables from the ETHERLINE® brand to fibre optic cables featuring POF or PCF designs from our HITRONIC® range, the Lapp Group has the right cabling solution for your PROFINET® application.

Connectors that are easy to connect play a particularly important role in Industrial Ethernet, whether it is the RJ45 that is familiar from office use or the M12 that is standard in the industrial environment. The EPIC® Data connector range is easy to connect to the matching cable – without the use of special tools. This not only saves time during assembly, this helps you, our customer, save money.

Overmoulded ETHERLINE® assemblies are also available in the range. These factory-tested products provide proven cable quality together with high-quality connectors. They feature guaranteed impermeability and guaranteed transmission characteristics. This helps you avoid spending time on assembly and prevents differences in connection quality, and even enables you to attain a higher protection class than can be achieved using field mountable connectors.



ETHERLINE® COPPER CABLES

- Copper data network cables for transmission in PROFINET® applications
- The right cable for almost every application area
- All current types are available with UL certification
- Special cables for highly flexible applications such as use in drag chains or for torsion applications
- For data transmission rates from 100 Mbit/s up to 10 Gbit/s with Cat.7 cables
- Cables are designed for harsh industrial use

ETHERLINE® ASSEMBLIES AND CONNECTORS

- Proven cable quality combined with high-quality connectors
- Highly flexible cables for transmission category Cat.6_A with overmoulded X-coded M12 connectors, suitable for drag chains or torsion applications
- Configurable connectors for field assembly – fast and without the use of special tools
- Straight or angled RJ45 connectors with colour-coded wire manager for easy connection to 2-pair or 4-pair cables

HITRONIC® FIBRE OPTIC CABLES

- Fibre optic cables for optical signal transmission in PROFINET® applications
- POF, PCF and GOF as fibre optic cable fibre type
- Cable designs for fixed installation (type B) or highly flexible use (type C)
- Sheath designs in PVC for standard applications and in PUR for applications with high mechanical load or chemical stress in the industrial environment
- Range of connector and assembly sets tailored to the cable designs
- Connector types LC, SC-RJ and ST(BFOC)

General information on the selection criteria and measures for proper application of cables and wires

Selection criterion Insulation and sheath materials

Every application makes its own demands of the cabling. The selection of the outer sheath material can be decisive in finding the suitable cable for an application.

To provide an overview of the properties of different sheath materials, the table (below left) lists four typical sheath materials that are used in PROFINET® applications.

The technical tables and the appendix in the Lapp main catalogue provide a detailed overview of all the properties of the ETHERLINE® and HITRONIC® cables. www.lappgroup.com/products

Polyurethane (PUR) is used in cables and wires that are designed for permanent flexing, e.g. in drag chain applications or torsion applications. In this context, these

cables must withstand high mechanical loads such as abrasion and lateral pressure.

Polyvinylchloride (PVC) is used in cables and wires that must meet requirements concerning resistance to chemical media or oil-resistance. PVC cables are also highly flame-retardant.

FRNC (flame-retardant non-corrosive) sheath materials are used wherever the absence of halogens is required in the context of a minor release of poisonous flue gas during a fire. These cables are frequently used as installation cables in the building infrastructure.

Polyethylene (PE) is normally used as a sheath material for cables that are suitable for direct burial. Further application areas include semi-permanent installation in water or outdoor applications. Together with carbon black (black sheath material), PE provides optimum protection against UV radiation.

PROPERTIES OF INSULATION AND SHEATHING OF CABLES AND WIRES

	PUR	PVC	FRNC	PE
Absence of halogens	+	--	+	+
Flame retardance	+	+	+	•
Low flue gas development	•	-	++	-
Low emissions of corrosive gases	•	--	++	•
Low flue gas toxicity	•	-	++	•
Abrasion resistance	++	+	-	•
Stripping	-	+	+	•
Oil-resistance	++	+	-	+
Acids	--	+	+	++

Legend:
 ++ = very good + = good • = moderate - = low -- = poor

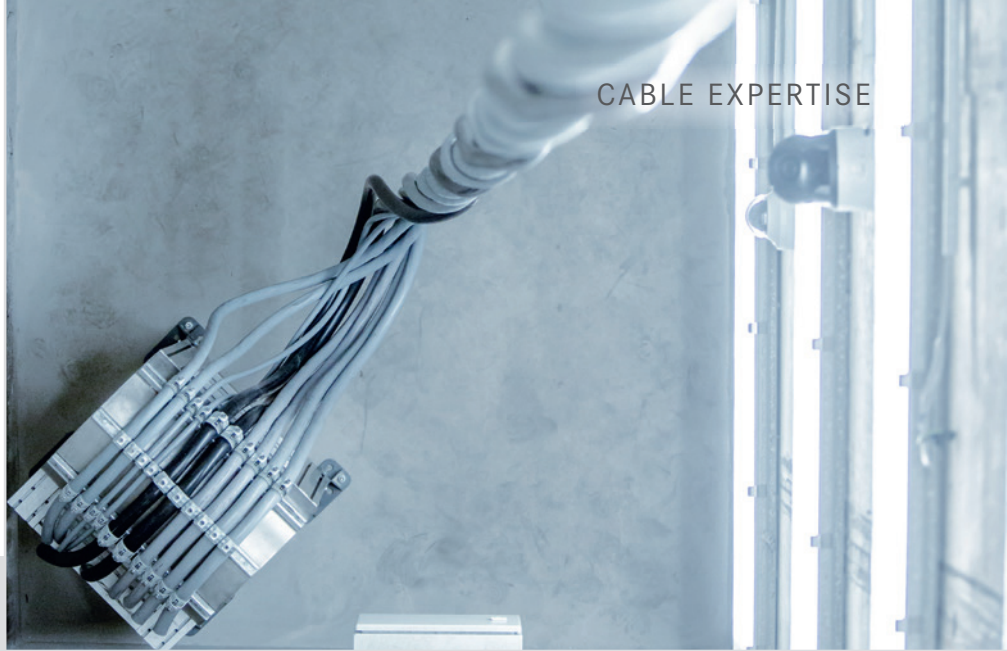

Cable requirements in highly dynamic systems

The cabling and connection solutions (data network cables, connecting and control cables, connectors and cable accessories) that are used are subjected to a wide range of mechanical loads during use and must be able to withstand these for a long period of time without sustaining any damage. In this context, this includes push and pull loads, pressure loads, bending, degree of bending freedom and torsional forces.

Push and pull forces generally refer to the loads that act on cables and connectors in a longitudinal direction. These forces are generally divided into three categories:

- Static: vertically hanging cables that are subject to gravity
- Dynamic: horizontally flexing cables in a guide chain that are subject to acceleration. For example, when used in power chains, the cable is subject to tensile force in both directions during acceleration
- Static and dynamic: vertically flexing cables in guide chain systems that are subject to acceleration forces, braking forces and gravity

An additional mechanical stress is applied to the cables during bending in guide chains. Accordingly, cables installed in drag chains must be suitable for power chains as they are subject to permanent bending stress along the entire length of the cable. A normal cable would not be able to withstand this highly dynamic load. The cables

in question are also subject to continuous alternate bending.

In addition to the materials used, the bending radius is decisive in ensuring a long service life in the context of an application such as this. It must be ensured that the specified minimum bending radius is not undershot or this will lead to 'kinking' of the cable, affecting the cable properties. This poses a risk of the cable design being affected, e.g. as a result of the distance between the cores being changed or due to breakage of the insulation or the core. In the case of data network cables, changes to the positioning of the core pairs in relation to one another leads to increased attenuation and characteristic impedance values. If these properties are changed, for example, this will inevitably lead to an interruption in transmission and/or a reduction in the data transmission rate.

In addition to the aforementioned applications in guiding systems (drag chains, cable protection hoses), applications featuring torsional loads such as the use of cables in robots or wind turbines are particularly significant in terms of the service life.

Torsional loads lead to torsional forces that twist the cable around the longitudinal axis in a positive and negative direction, which also results in the cable being subject to a high dynamic load.

Cable criteria for the American market

With respect to the use of cables and wires in North America and Canada, these must first be checked for potential risks such as their flammability and electric shock. The regulations in this regard are stated in the NEC (National Electrical Code), which is issued by the NFPA (National Fire Protection Association). The different application areas of the cables and wires led to the definition of different requirements concerning fire behaviour.

In the proper use of cables and wires, a distinction is also made between 'listed cables & wires' and 'Appliance Wiring Material'.

The figure shows the most important NEC and NFPA codes for an industrial manufacturing facility. Every code involves different requirements for the cables and lines used.

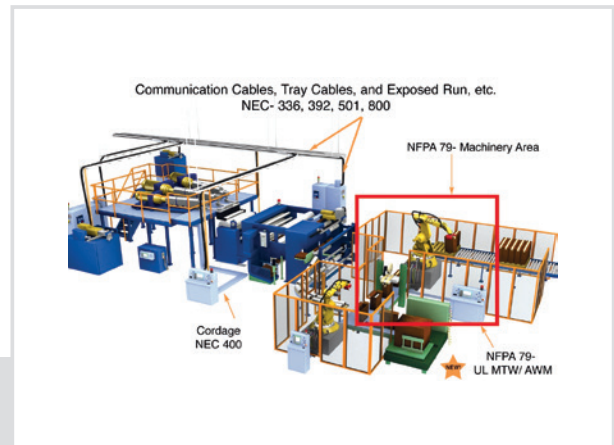

Listed cables & wires

The initial category defines fixed cabling in buildings for residential purposes, as well as commercial and industrial use. Listed cables and wires not only have to meet individual UL product standards, but must also comply with the relevant articles of the National Electrical Code (NEC). The NEC contains detailed specifications relating to the correct usage of listed cables and wires. The listed cables and wires can be used for factory wiring of electrical equipment, devices, appliances and machinery as well as for on-site or field cabling of industrial machinery and plants according to NFPA 79.

Appliance Wiring Material (AWM)

AWM includes cables and wires intended for the use of electrical equipment, devices, appliances, control cabinets and industrial machinery that are fully wired ex works. AWM is not intended for field wiring purposes. Cables and wires with AWM-style UL labelling must be used for individual applications as stipulated by the relevant style designation. The use of cables with AWM classification is restricted to the applications that are stated in the corresponding description (www.ul.com).

NEC

Article 800 of the NEC dedicates the chapter ‘Communication Circuits’ to data network cables. This chapter distinguishes between different fire behaviour levels: the higher the level, the higher the requirements relating to fire behaviour. All levels are downward compatible (see table).

Application areas

of the respective approvals:

- Plenum: no additional protection in closed cable ducts via suspended ceilings or air supply
- Riser: installation in riser duct between a minimum of two storeys
- General purpose: general applications; standard in machinery and plant engineering
 - CMG/CM: connection of machine or production cell to control cabinet
 - PLTC: metallicly protected installation on open cable conduits and between other devices
 - PLTC-ER: free and open installation on cable conduit and between cable conduit and industrial machinery/plant
- Residential: CMX: limited to use within a machine or production cell (automation island)

NEC HIERARCHY

	Communication Cables	Nonconductive Optical Fibre Cables	Conductive Optical Fibre Cables	Tray Cables
Plenum FR-05 NFPA 262, UL910 (Steiner Tunnel)	CMP ↓	OFNP ↓	→ OFCP ↓	
Riser FR-04, UL 1666 (Vertical Shaft)	CMR ↓	OFNR ↓	→ OFCR ↓	
General purpose FR-03, UL 1581 (Vertical Tray or CSA FT4)	CMG CM ↓	OFNG OFN ↓	→ OFCG OFC	TC-ER ↓ TC
Residential FR-02 UL 1581, VW-1 (Vertical Flame)	CMX			

COPPER CABLES IN FOCUS

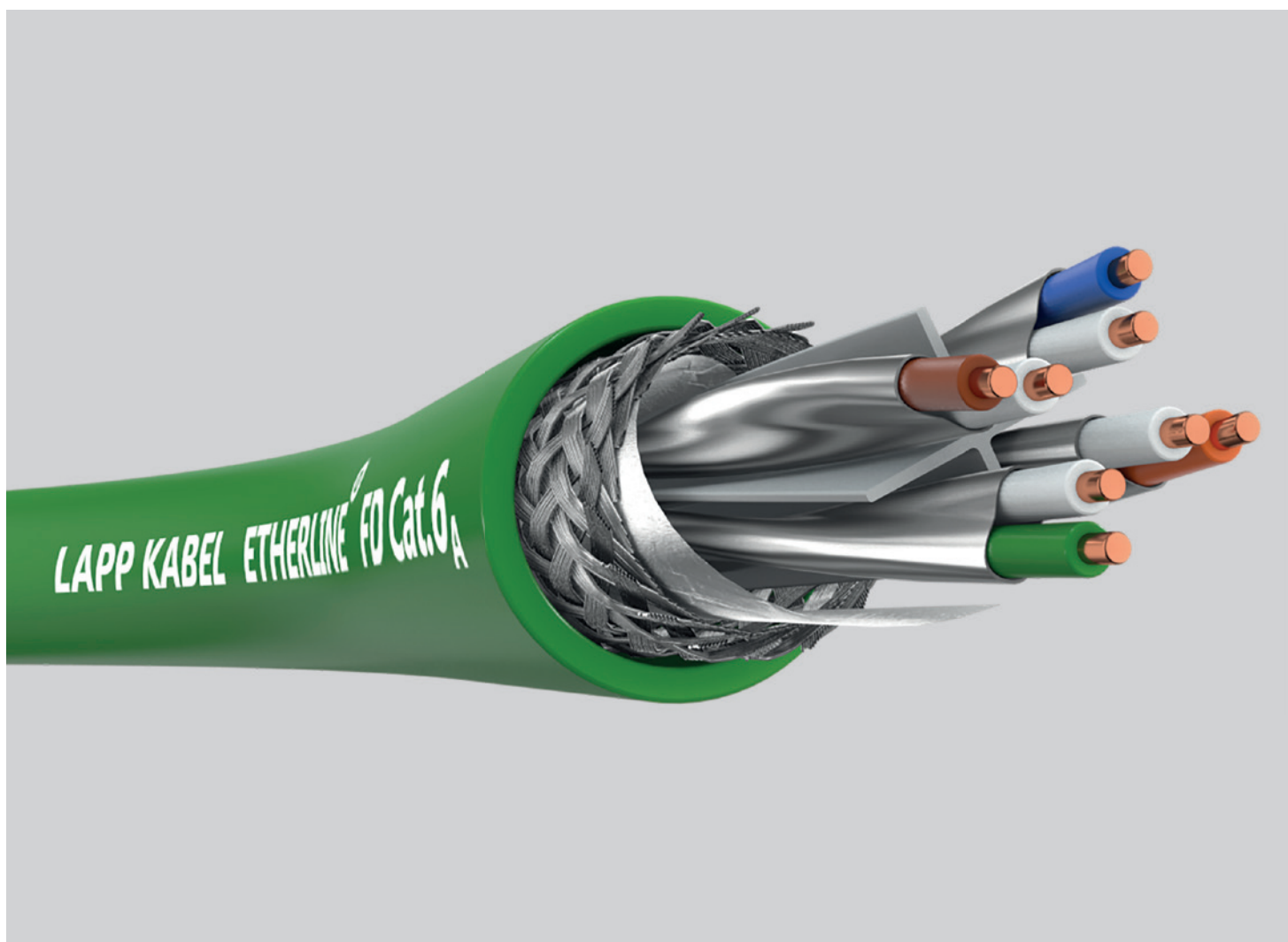



Industrial cabling with copper data cables

Copper conductors are often used for the purpose of cabling machinery and plants, as well as for generic cabling within a building. With respect to various applications and services, the international

standardisation has been used to standardise transmission classes with the corresponding transmission categories for the components. All categories are downward compatible.

APPLICATION CLASSES OF LAN CABLES (COPPER CABLING)

Application class	Category	Transmission frequency	Services and applications
Class A	-	Up to 100 kHz	
Class B	-	Up to 1 MHz	Telephone, ISDN
Class C	Cat.3	Up to 16 MHz	Telephone, ISDN, TokenRing, Ethernet
Class D	Cat.5/5e	Up to 100 MHz	100 Mbit/s (Fast Ethernet) 1Gbit/s (Gigabit Ethernet)
Class E	Cat.6	Up to 250 MHz	100 Mbit/s (Fast Ethernet) 1Gbit/s (Gigabit Ethernet)
Class E _A	Cat.6 _A	Up to 500 MHz	100 Mbit/s (Fast Ethernet) 1Gbit/s (Gigabit Ethernet) 10Gbit/s (10 Gigabit Ethernet)
Class F	Cat.7	Up to 600 MHz	100 Mbit/s (Fast Ethernet) 1Gbit/s (Gigabit Ethernet) 10Gbit/s (10 Gigabit Ethernet)
Class F _A	Cat.7 _A	Up to 1 GHz	100 Mbit/s (Fast Ethernet) 1Gbit/s (Gigabit Ethernet) 10Gbit/s (10 Gigabit Ethernet)

CABLE DESIGN

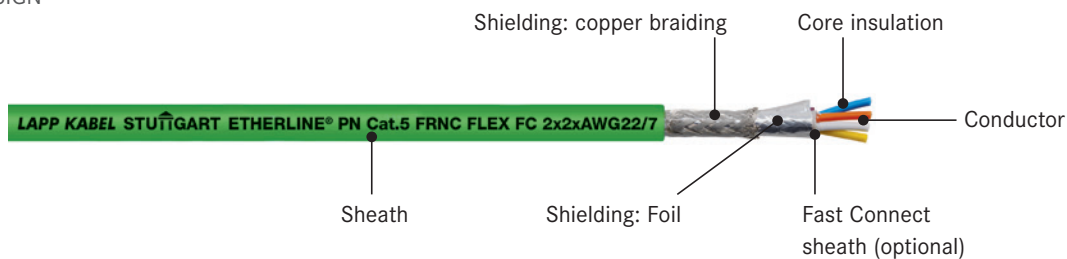

General information on PROFINET® / type specification according to the PROFINET® guideline

General structure

Data network cables may feature different structures. A general structure is shown in the figure above. In this case, the respective components fulfil the following functions:

- Sheath: protection against chemical media or mechanical influences
- Shielding:
 - Copper braiding: protection against external EMC influences
 - Foil screening as overall screening: protection against external EMC influences, protection against crosstalk from two data network cables (from inside to outside)
 - Foil screening as individual pair screening: screening of the individual core pairs from one another (reduction of near end crosstalk)
- Fast Connect sheath (optional): sheath and shielding are cut to the right length for quick connection to the connector
- Core insulation: responsible for the transmission characteristics, e.g. capacity or characteristic impedance
- Conductor: electrical connection for data and power

PROFINET® guideline

The Industrial Ethernet system PROFINET® was developed by Siemens AG together with the PROFIBUS & PROFINET® User Organization (PNO). This organization is now active worldwide and has hundreds of members.

The PROFINET® system is specified internationally in IEC 61918 'Industrial communication networks - Installation of communication networks in industrial premises' for cabling within and between automation islands and/or production islands. The specific infrastructure for PROFINET® cabling and connection solutions is standardised in turn in IEC 61784-5-3. This applies for copper-based and fibre optic transmission media and wireless transmission. The 'PROFINET® Cabling and Interconnection Technology Guideline' is created by a working group within the PNO. This guideline reflects IEC 61784-5-3. It always specifies three cable types for copper conductors - for 2-pair and 4-pair cables. This specification therefore defines the exact structure and the mechanical and electrical requirements.

- Type A: for fixed installation, no flexing after installation (solid conductor)
- Type B: for flexible installation, occasional flexing of the cable following installation (7-wire stranded conductor)
- Type C: for special requirements such as use in power chains, torsion applications, etc. (solid wire or flexible stranded conductors with up to 19-wire structure)

Two cable types are defined for hybrid cables (data pairs and control cores).

- Type B: for flexible installation, occasional flexing of the cable following installation, and vibrations
- Type C: for special applications such as use in power chains, torsion applications, etc.

Initially, PROFINET® was specified only for transmission of data at 100 Mbit/s with 2-pair Cat.5 cables. However, in order to make this Industrial Ethernet system even more efficient, 4-pair cables for transmission of data at up to 10 Gbit/s have also been standardised since 2013. The following dimensions have been defined for the three specified cable types respectively.

The following table provides an overview of the cables and wires available from the Lapp Group for specific cabling according to the PROFINET® specifications:

Number of pairs/cable type	Type A	Type B	Type C
2-pair (2x2)	AWG22/1	AWG22/7	AWG22/1...19
4-pair (4x2)	Min. AWG23/1	Min. AWG23/7	Min. AWG24/1...19

The complete range: sensor/actuator cabling

PROFINET® guideline

In addition to the cables and connectors for data transmission, the PROFINET® guideline also specifies connectors for the power supply.

One example of this is the M12 A-coded connector that is available in both a connector design and a female design. The M12 connector corresponds to IEC 60512 and is defined as either a 4-pin or 5-pin design.

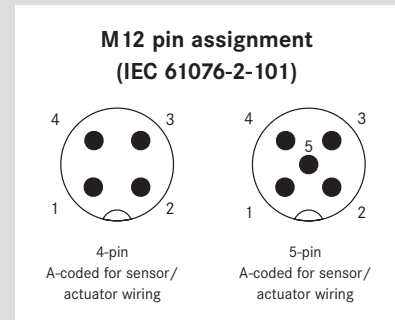

Sensor/actuator flush-type connectors and field mountable connectors

For the purpose of connecting devices, we recommend M12 flush-type connectors with integrated stranded wire for PCB connection or a fast connection. Use field mountable connectors for rapid configuration of individual cable

lengths for M8 and M12 sensor/actuator cables. Whether you need a screw connection or a fast connection, we will deliver according to your requirements.



Sensor/actuator cables

Do you need to perform quick cabling of sensors and actuators in the field? Not a problem – thanks to our comprehensive range of overmoulded cables with M8, M12 and valve connector connections.

Signal statuses can be monitored with ease by means of the sensor/actuator cable designs featuring LEDs. Cables with a screened wire also comply with the requirements concerning increased EMC compatibility.



Sensor/actuator boxes

In standardised connection systems, sensor/actuator boxes enable connection with all commonly used sensors and actuators and are the solution for decentralising small-scale I/O. Regardless of whether the installation is to be performed on profiles, on even surfaces or under challenging condi-

tions, the assembly concept ensures flexibility and reduces installation costs. The devices enable two assembly directions and are suitable for all uses. The allocation of the connectors also ensures that assembly time is kept to a minimum even under challenging conditions.

You can find the complete range of sensor/actuator cabling either in the Automation & Network Guide or by using the preassembled cable finder on our website: www.lappgroup.com/assemblyfinder

2-pair copper conductor



PROFINET® TYPE A 2-PAIR:
CAT.5 CABLES FOR FIXED INSTALLATION

Product image	1	2	3
Product	ETHERLINE® PN Cat.5e Y	ETHERLINE® Y FC Cat.5	ETHERLINE® TRAY ER PN Y FC Cat.5e
Article number	2170891	2170893	2170879
Application area	<ul style="list-style-type: none"> For fixed installation between machinery and plants Wiring of machinery, devices and control cabinets Can be used in dry or damp rooms 	<ul style="list-style-type: none"> For fixed installation between machinery and plants Wiring of machinery, devices and control cabinets Can be used in dry or damp rooms Also suitable for outdoor applications Installation on closed cable conduits With 600 V rating for installation near live cables 	<ul style="list-style-type: none"> For fixed installation between machinery and plants Wiring of machinery, devices and control cabinets Can be used in dry or damp rooms Also suitable for outdoor applications Installation on open cable conduits With 600 V rating for installation near live cables
Properties	<ul style="list-style-type: none"> Cat.5 according to IEC 61156-5 UL (CMX) approval Flame-retardant according to IEC 60332-1-2 and VW-1 according to UL 1581 	<ul style="list-style-type: none"> Cat.5 according to EN 50288-2-1 UL (PLTC) and UL (CMG) approval 75°C AWM style 21694 Flame-retardant according to UL 1685 (CSA FT 4) UV-resistant according to UL 1581 Sec. 1200 	<ul style="list-style-type: none"> Cat.5 according to EN 50288-2-1 UL (PLTC-ER) and UL (CMG) approval 75°C AWM style 21694 Flame-retardant according to UL 1685 (CSA FT 4) UV-resistant according to UL 1581 Sec. 1200
Temperature range	<ul style="list-style-type: none"> Flexing: -5°C up to +50°C Fixed installation: -40°C up to +75°C 	<ul style="list-style-type: none"> Flexing: -20°C up to +60°C Fixed installation: -40°C up to +80°C 	<ul style="list-style-type: none"> Flexing: -20°C up to +60°C Fixed installation: -40°C up to +80°C
Bending radius	<ul style="list-style-type: none"> Flexing: 7.5 x cable diameter Fixed installation: 3 x cable diameter 	<ul style="list-style-type: none"> Flexing: 15 x cable diameter Fixed installation: 10 x cable diameter 	<ul style="list-style-type: none"> Flexing: 15 x cable diameter Fixed installation: 10 x cable diameter
Cable structure (inside to outside)	<ul style="list-style-type: none"> Star quad structure Solid bare copper conductor with PE insulation Double shielding consisting of plastic-laminated foil and shield braiding made from tinned copper wires (85% degree of coverage) PVC outer sheath material Max. outer diameter 6.5 mm 	<ul style="list-style-type: none"> Star quad structure Solid bare copper conductor with PE insulation Inner sheath made from PVC for Fast Connect system Double shielding consisting of plastic-laminated foil and shield braiding made from tinned copper wires (85% degree of coverage) PVC outer sheath material Max. outer diameter 6.8 mm 	<ul style="list-style-type: none"> Star quad structure Solid bare copper conductor with PE insulation Inner sheath made from PVC for Fast Connect system Double shielding consisting of plastic-laminated foil and shield braiding made from tinned copper wires (85% degree of coverage) PVC outer sheath material Max. outer diameter 6.8 mm

2-pair copper conductor



PROFINET® TYPE B 2-PAIR:
CAT.5 CABLES FOR FLEXIBLE USE

Product image	4	5	6	7
Product	ETHERLINE® PN Cat.5 Y FLEX FC	ETHERLINE® PN Cat.5 FRNC FLEX FC	ETHERLINE® MARINE FRNC FC Cat.5	ETHERLINE® Cat.5e 105 plus
Article number	2170886	2170890	2170889	2170636
Application area	<ul style="list-style-type: none"> For fixed installation and flexible applications between machinery and plants Wiring of machinery, devices and control cabinets Can be used in dry or damp rooms Also suitable for outdoor applications Installation on closed cable conduits With 600 V rating for installation near live cables 	<ul style="list-style-type: none"> For fixed installation and flexible applications between machinery and plants Wiring of machinery, devices and control cabinets Can be used in dry or damp rooms Installation on closed cable conduits 	<ul style="list-style-type: none"> For fixed installation on and below deck on civilian ships between machinery and plants Can be used in dry or damp rooms Also suitable for outdoor applications 	<ul style="list-style-type: none"> Wind turbines: for installation in the hollow shaft between the transmission and the pitch system For fixed installation and flexible applications between machinery and plants Can be used in dry or damp rooms Also suitable for outdoor applications High temperature resistance
Properties	<ul style="list-style-type: none"> Cat.5 according to EN 50288-2-1 UL (PLTC) and UL (CMG) approval 75°C AWM style 21694 Flame-retardant according to UL 1685 (CSA FT 4) UV-resistant according to UL 1581 Sec. 1200 	<ul style="list-style-type: none"> Cat.5e according to EN 50288-2-1 UL (PLTC) and UL (CMG) approval 75°C Flame-retardant according to UL 1685 (CSA FT 4) UV-resistant according to UL 1581 Sec. 1200 	<ul style="list-style-type: none"> Cat.5 according to EN 50288-2-1 Approvals: Germanischer Lloyd, Lloyds Register of Shipping ABS Europe Ltd Bureau Veritas Det Norske Veritas (DNV) Flame-retardant according to IEC 60332-3 Halogen-free according to IEC 60754-1 and -2 	<ul style="list-style-type: none"> Cat.5 according to IEC 61156-5
Temperature range	<ul style="list-style-type: none"> Flexing: -20°C up to +60°C Fixed installation: -40°C up to +80°C 	<ul style="list-style-type: none"> Flexing: -25°C up to +80°C Fixed installation: -25°C up to +80°C 	<ul style="list-style-type: none"> Flexing: 0°C up to +50°C Fixed installation: -25°C up to +70°C 	<ul style="list-style-type: none"> Fixed installation: -40°C up to +105°C Flexing: -30°C up to +105°C Short-term max. 4500 h: +120°C
Bending radius	<ul style="list-style-type: none"> Flexing: 15 x cable diameter Fixed installation: 10 x cable diameter 	<ul style="list-style-type: none"> Flexing: 8 x cable diameter Fixed installation: 4 x cable diameter 	<ul style="list-style-type: none"> During installation: 7.5 x cable diameter Fixed installation: 3 x cable diameter 	<ul style="list-style-type: none"> During installation: 15 x cable diameter Fixed installation: 10 x cable diameter
Cable structure (inside to outside)	<ul style="list-style-type: none"> Star quad structure Tinned 7-wire braided conductor with PE insulation Inner sheath made from PVC for Fast Connect system Double shielding consisting of plastic-laminated foil and shield braiding made from tinned copper wires (85% degree of coverage) PVC outer sheath material Max. outer diameter 6.8 mm 	<ul style="list-style-type: none"> Star quad structure Tinned 7-wire braided conductor with PE insulation Inner sheath made from flame-retardant halogen-free material for Fast Connect system Double shielding consisting of plastic-laminated foil and shield braiding made from tinned copper wires (85% degree of coverage) FRNC outer sheath material Max. outer diameter 6.8 mm 	<ul style="list-style-type: none"> Star quad structure Tinned 7-wire braided conductor with PE insulation Inner sheath made from flame-retardant halogen-free material for Fast Connect system Double shielding consisting of plastic-laminated foil and shield braiding made from tinned copper wires (85% degree of coverage) Max. outer diameter of FRNC outer sheath material 6.8 mm 	<ul style="list-style-type: none"> Star quad structure Bare 7-wire braided conductor with PE insulation (heat-resistant) Double shielding consisting of plastic-laminated foil and shield braiding made from tinned copper wires (85% degree of coverage) Max. outer diameter of TPE outer sheath material 6.5 mm

2-pair copper conductor



PROFINET® TYPE C 2-PAIR:
CAT.5 CABLES FOR SPECIAL USE

Product image	8	9	10	11
Product	ETHERLINE® FD P FC Cat.5	ETHERLINE® TORSION Cat.5	ETHERLINE® Cat.5 ARM	ETHERLINE® Y Cat.5e BK
Article number	2170894	2170888	2170496	2170901
Application area	<ul style="list-style-type: none"> For highly flexible applications such as use in drag chains Wiring of machinery, devices and control cabinets Can be used in dry or damp rooms Also suitable for outdoor applications Largely resistant to oils and greases 	<ul style="list-style-type: none"> For highly flexible applications such as use in torsion applications For a minimum of one million cycles at $\pm 180^\circ$ /m Wiring of machinery, devices and control cabinets Can be used in dry or damp rooms Also suitable for outdoor applications Largely resistant to oils and greases 	<ul style="list-style-type: none"> For fixed installation between machinery and plants For more demanding mechanical stresses Rodent protection via two layers of galvanised steel tape Can be used in dry or damp rooms Also suitable for outdoor applications 	<ul style="list-style-type: none"> For fixed installation and flexible applications between machinery and plants Wiring of machinery, devices and control cabinets Can be used in dry or damp rooms Also suitable for outdoor applications
Properties	<ul style="list-style-type: none"> Cat.5 according to EN 50288-2-2 UL (CMX) approval Flame-retardant according to UL 1581 (VW-1) Halogen-free according to VDE 0472-815 	<ul style="list-style-type: none"> Cat.5 according to EN 50288-2-2 UL (AWM) style 21161 (80°C) Flame-retardant according to IEC 60332-1-2 and UL 1581 (horizontal flame test) Halogen-free according to VDE 0472-815 	<ul style="list-style-type: none"> Cat.5 according to EN 50288-2-1 UV-resistant Hydrolysis-resistant 	<ul style="list-style-type: none"> Cat.5 according to IEC 61156-5 Flame-retardant according to IEC 60332-1-2 UV-resistant
Temperature range	<ul style="list-style-type: none"> Flexing: -20°C up to +60°C Fixed installation: -30°C up to +70°C 	<ul style="list-style-type: none"> Flexing: -40°C up to +80°C 	<ul style="list-style-type: none"> Flexing: -20°C up to +60°C Fixed installation: -40°C up to +70°C 	<ul style="list-style-type: none"> Fixed installation: -40°C up to +80°C
Bending radius	<ul style="list-style-type: none"> Flexing: 8 x cable diameter 	<ul style="list-style-type: none"> Flexing: 5 x cable diameter 	<ul style="list-style-type: none"> Flexing: 15 x cable diameter Fixed installation: 10 x cable diameter 	<ul style="list-style-type: none"> Flexing: 15 x cable diameter Fixed installation: 10 x cable diameter
Cable structure (inside to outside)	<ul style="list-style-type: none"> Star quad structure Tinned 7-wire braided conductor with PE insulation Inner sheath made from flame-retardant halogen-free material for Fast Connect system Double shielding consisting of plastic-laminated foil and shield braiding made from tinned copper wires (85% degree of coverage) PUR outer sheath material, green RAL 6018 Max. outer diameter 6.8 mm 	<ul style="list-style-type: none"> Star quad structure Tinned 19-wire braided conductor with foam skin PE insulation Fleece shield braiding made from tinned copper wires (85% degree of coverage) PUR outer sheath material, green RAL 6018 Max. outer diameter 6.8 mm 	<ul style="list-style-type: none"> Star quad structure Solid bare copper conductor with PE insulation Plastic tape Inner sheath made from PVC material for Fast Connect system Double shielding consisting of plastic-laminated foil and shield braiding made from tinned copper wires (85% degree of coverage) PVC inner sheath, green; max. outer diameter 6.7 mm Two layers of galvanised steel tape PE outer sheath material, black Max. outer diameter 9.8 mm 	<ul style="list-style-type: none"> Star quad structure Bare 7-wire braided conductor with PE insulation Double shielding consisting of plastic-laminated foil and shield braiding made from tinned copper wires (85% degree of coverage) PVC outer sheath material, black Max. outer diameter 6.5 mm

4-pair copper conductor

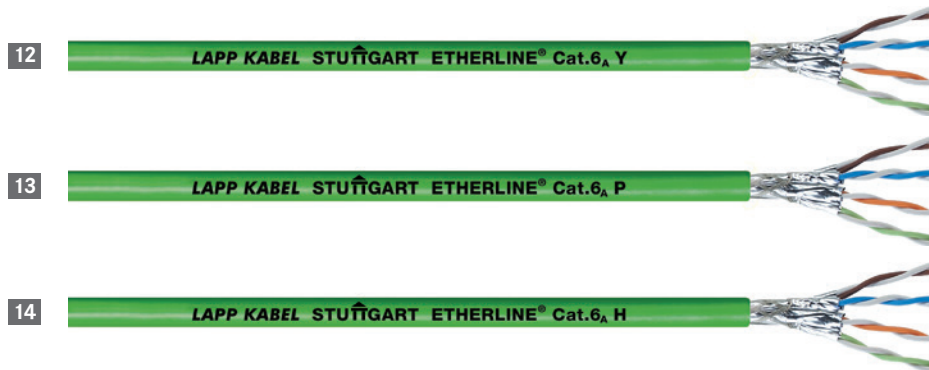

PROFINET® TYPE A 4-PAIR:
CAT.6_A CABLES FOR FIXED INSTALLATION

Product image	12	13	14
Product	ETHERLINE® Cat.6 _A Y	ETHERLINE® Cat.6 _A P	ETHERLINE® Cat.6 _A H
Article number	2170464	2170465	2170466
Application area	<ul style="list-style-type: none"> For fixed installation between machinery and plants Wiring of machinery, devices and control cabinets Can be used in dry or damp rooms Installation on closed cable conduits 	<ul style="list-style-type: none"> For fixed installation between machinery and plants Wiring of machinery, devices and control cabinets Can be used in dry or damp rooms For more demanding mechanical requirements 	<ul style="list-style-type: none"> For fixed installation between machinery and plants Wiring of machinery, devices and control cabinets Can be used in dry or damp rooms Where the absence of halogens is required
Properties	<ul style="list-style-type: none"> Cat.6_A according to IEC 61156-5 UL (CMG) approval 75°C Flame-retardant according to IEC 60332-3-24 and FT4 according to UL 1685/CSA Oil-resistant I according to UL 1581 Sec. 480 UV-resistant according to UL 1581 Sec. 1200 	<ul style="list-style-type: none"> Cat.6_A according to IEC 61156-5 UL (CMX) approval 75°C Flame-retardant according to IEC 60332-1-2 and VW-1 according to UL 1581 Sec. 1080 Oil-resistant according to IEC 60811-2-1 or DIN VDE 0282 Part 10 Halogen-free according to IEC 60754 or DIN VDE 0472 Part 815 	<ul style="list-style-type: none"> Cat.6_A according to IEC 61156-5 Flame-retardant according to IEC 60332-3-24 Halogen-free according to IEC 60754 or DIN VDE 0472 Part 815
Temperature range	Fixed installation: -40°C up to +80°C	Fixed installation: -40°C up to +80°C	Fixed installation: -25°C up to +80°C
Bending radius	Fixed installation: 10 x cable diameter	Fixed installation: 10 x cable diameter	Fixed installation: 10 x cable diameter
Cable structure (inside to outside)	<ul style="list-style-type: none"> 2 cores stranded as pair, 4 screened pairs to cable core (4x2xAWG22) Solid bare copper conductor with foam skin PE insulation Pair screening made from plastic-laminated foil Overall screening consisting of braiding made from tinned copper wires (85% degree of coverage) PVC outer sheath material Max. outer diameter 9.0 mm 	<ul style="list-style-type: none"> 2 cores stranded as pair, 4 screened pairs to cable core (4x2xAWG22) Solid bare copper conductor with foam skin PE insulation Pair screening made from plastic-laminated foil Overall screening consisting of braiding made from tinned copper wires (85% degree of coverage) PUR outer sheath material Max. outer diameter 9.0 mm 	<ul style="list-style-type: none"> 2 cores stranded as pair, 4 screened pairs to cable core (4x2xAWG22) Solid bare copper conductor with foam skin PE insulation Pair screening made from plastic-laminated foil Overall screening consisting of braiding made from tinned copper wires (85% degree of coverage) FRNC outer sheath material Max. outer diameter 9.0 mm

4-pair copper conductor

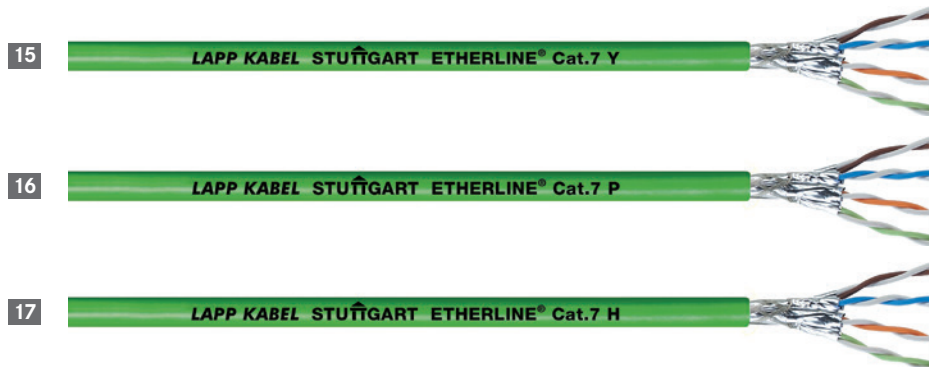

PROFINET® TYPE A 4-PAIR:
CAT.7 CABLES FOR FIXED INSTALLATION

Product image	15	16	17
Product	ETHERLINE® Cat.7 Y	ETHERLINE® Cat.7 P	ETHERLINE® Cat.7 H
Article number	2170474	2170475	2170476
Application area	<ul style="list-style-type: none"> • For fixed installation between machinery and plants • Wiring of machinery, devices and control cabinets • Can be used in dry or damp rooms • Installation on closed cable conduits 	<ul style="list-style-type: none"> • For fixed installation between machinery and plants • Wiring of machinery, devices and control cabinets • Can be used in dry or damp rooms • For more demanding mechanical requirements 	<ul style="list-style-type: none"> • For fixed installation between machinery and plants • Wiring of machinery, devices and control cabinets • Can be used in dry or damp rooms • Where the absence of halogens is required
Properties	<ul style="list-style-type: none"> • Cat.7 according to IEC 61156-5 • UL (CMG) approval 75°C • Flame-retardant according to IEC 60332-3-24 and FT4 according to UL 1685/CSA • Oil-resistant I according to UL 1581 Sec. 480 • UV-resistant according to UL 1581 Sec. 1200 	<ul style="list-style-type: none"> • Cat.7 according to IEC 61156-5 • UL (CMX) approval 75°C • Flame-retardant according to IEC 60332-1-2 and VW-1 according to UL 1581 Sec. 1080 • Oil-resistant according to IEC 60811-2-1 or DIN VDE 0282 Part 10 • Halogen-free according to IEC 60754 or DIN VDE 0472 Part 815 	<ul style="list-style-type: none"> • Cat.7 according to IEC 61156-5 • Flame-retardant according to IEC 60332-3-24 • Halogen-free according to IEC 60754 or DIN VDE 0472 Part 815
Temperature range	• Fixed installation: -40°C up to +80°C	• Fixed installation: -40°C up to +80°C	• Fixed installation: -25°C up to +80°C
Bending radius	• Fixed installation: 10 x cable diameter	• Fixed installation: 10 x cable diameter	• Fixed installation: 10 x cable diameter
Cable structure (inside to outside)	<ul style="list-style-type: none"> • 2 cores stranded as pair, 4 screened pairs to cable core (4x2xAWG22) • Solid bare copper conductor with foam skin PE insulation • Pair screening made from plastic-laminated foil • Overall screening consisting of braiding made from tinned copper wires (85% degree of coverage) • PVC outer sheath material • Max. outer diameter 9.0 mm 	<ul style="list-style-type: none"> • 2 cores stranded as pair, 4 screened pairs to cable core (4x2xAWG22) • Solid bare copper conductor with foam skin PE insulation • Pair screening made from plastic-laminated foil • Overall screening consisting of braiding made from tinned copper wires (85% degree of coverage) • PUR outer sheath material • Max. outer diameter 9.0 mm 	<ul style="list-style-type: none"> • 2 cores stranded as pair, 4 screened pairs to cable core (4x2xAWG22) • Solid bare copper conductor with foam skin PE insulation • Pair screening made from plastic-laminated foil • Overall screening consisting of braiding made from tinned copper wires (85% degree of coverage) • FRNC outer sheath material • Max. outer diameter 9.0 mm

4-pair copper conductor

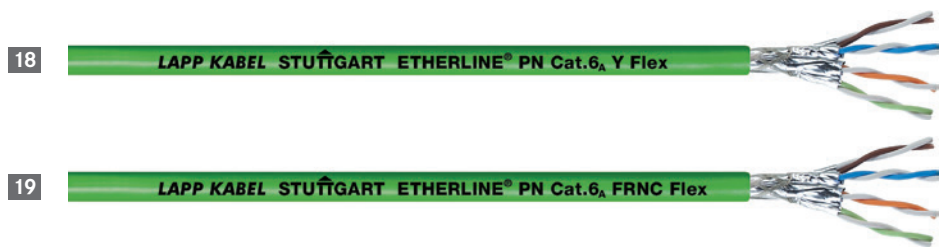

PROFINET® TYPE B 4-PAIR:
CAT.6_A CABLES FOR FLEXIBLE USE

Product image	18	19
Product	ETHERLINE® PN Cat.6_A Y FLEX	ETHERLINE® PN Cat.6_A FRNC FLEX
Article number	2170930	2170931
Application area	<ul style="list-style-type: none"> • For fixed installation and flexible applications between machinery and plants • Wiring of machinery, devices and control cabinets • Can be used in dry or damp rooms • Installation on closed cable conduits 	<ul style="list-style-type: none"> • For fixed installation and flexible applications between machinery and plants • Wiring of machinery, devices and control cabinets • Can be used in dry or damp rooms • Where the absence of halogens is required
Properties	<ul style="list-style-type: none"> • Cat.6_A according to IEC 61156-5 • UL (CMG) approval 75°C • Flame-retardant according to IEC 60332-3-24 and UL 1685 (CSA FT 4) • Oil-resistant I according to UL 1581 Sec. 480 	<ul style="list-style-type: none"> • Cat.6_A according to IEC 61156-5 • UL (CM) approval • Flame-retardant according to IEC 60332-1-2
Temperature range	• Flexing/fixed installation: -10°C up to +70°C	• Fixed installation: -25°C up to +80°C
Bending radius	<ul style="list-style-type: none"> • Flexing: 15 x cable diameter • Fixed installation: 8 x cable diameter 	<ul style="list-style-type: none"> • Flexing: 15 x cable diameter • Fixed installation: 8 x cable diameter
Cable structure (inside to outside)	<ul style="list-style-type: none"> • 2 cores stranded as pair, 4 screened pairs to cable core (4x2xAWG23) • Tinned 7-wire braided conductor with foam skin PE insulation • Pair screening made from plastic-laminated foil • Overall screening consisting of braiding made from tinned copper wires (85% degree of coverage) • PVC outer sheath material • Max. outer diameter 9.0 mm 	<ul style="list-style-type: none"> • 2 cores stranded as pair, 4 screened pairs to cable core (4x2xAWG23) • Tinned 7-wire braided conductor with foam skin PE insulation • Pair screening made from plastic-laminated foil • Overall screening consisting of braiding made from tinned copper wires (85% degree of coverage) • FRNC outer sheath material • Max. outer diameter 9.0 mm

4-pair copper conductor

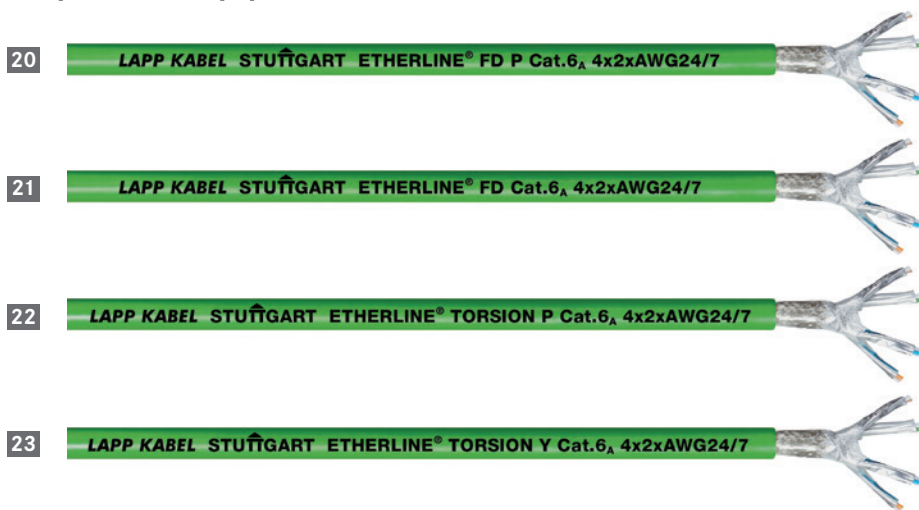

PROFINET® TYPE C 4-PAIR:
CAT.6_A CABLES FOR SPECIAL USE

Product image	20	21	22	23
Product	ETHERLINE® FD P Cat.6 _A	ETHERLINE® FD Cat.6 _A	ETHERLINE® TORSION P Cat.6 _A	ETHERLINE® TORSION Y Cat.6 _A
Article number	2170484	2170485	2170483	2170482
Application area	<ul style="list-style-type: none"> For highly flexible applications such as use in drag chains Min. 2.5 million bending cycles Wiring of machinery, devices and control cabinets Can be used in dry or damp rooms Also suitable for outdoor applications Largely resistant to oils and greases 1000 V rating enables cable routing near live cables (according to UL 758) 	<ul style="list-style-type: none"> For highly flexible applications such as use in drag chains Min. 2.5 million bending cycles Wiring of machinery, devices and control cabinets Can be used in dry or damp rooms 	<ul style="list-style-type: none"> For torsion applications, e.g. in wind turbines Min. 1 million cycles with flexing of ±180°/metre Wiring of machinery, devices and control cabinets Can be used in dry or damp rooms Also suitable for outdoor applications Largely resistant to oils and greases 1000 V rating enables cable routing near live cables (according to UL 758) 	<ul style="list-style-type: none"> For torsion applications, e.g. in wind turbines Min. 1 million cycles with flexing of ±180°/metre Wiring of machinery, devices and control cabinets Can be used in dry or damp rooms
Properties	<ul style="list-style-type: none"> Cat.6_A according to IEC 61156-6 UL (CMX) approval UL (AWM) style 21576 (1000 V, 80°C) Flame-retardant according to UL 1581 (VW-1) Oil-resistant according to IEC 60811-2-1 Halogen-free according to VDE 0472-815 	<ul style="list-style-type: none"> Cat.6_A according to IEC 61156-6 UL (CM) approval Flame-retardant according to IEC 60332-1-2, vertical tray according to UL 1685 Oil-resistant according to IEC 60811-2-1 	<ul style="list-style-type: none"> Cat.6_A according to IEC 61156-6 UL (CMX) approval UL (AWM) style 21576 (1000 V, 80°C) Flame-retardant according to UL 1581 (VW-1) Oil-resistant according to IEC 60811-2-1 Halogen-free according to VDE 0472-815 	<ul style="list-style-type: none"> Cat.6_A according to IEC 61156-6 UL (CM) approval Flame-retardant according to IEC 60332-1-2, vertical tray according to UL 1685 Oil-resistant according to IEC 60811-2-1
Temperature range	<ul style="list-style-type: none"> Flexing: -30°C up to +70°C Fixed installation: -40°C up to +80°C 	<ul style="list-style-type: none"> Flexing: -10°C up to +70°C Fixed installation: -40°C up to +80°C 	<ul style="list-style-type: none"> Flexing: -30°C up to +70°C Fixed installation: -40°C up to +80°C 	<ul style="list-style-type: none"> Flexing: -10°C up to +70°C Fixed installation: -40°C up to +80°C
Bending radius	<ul style="list-style-type: none"> Flexing: 15 x cable diameter Fixed installation: 8 x cable diameter 	<ul style="list-style-type: none"> Flexing: 15 x cable diameter Fixed installation: 8 x cable diameter 	<ul style="list-style-type: none"> Flexing: 15 x cable diameter Fixed installation: 8 x cable diameter 	<ul style="list-style-type: none"> Flexing: 15 x cable diameter Fixed installation: 8 x cable diameter
Cable structure (inside to outside)	<ul style="list-style-type: none"> 2 cores stranded as pair, 4 screened pairs to cable core (4x2xAWG24) Tinned 7-wire braided conductor with foam skin PE insulation Pair screening made from plastic-laminated foil Overall screening consisting of braiding made from tinned copper wires (85% degree of coverage) PUR outer sheath material Max. outer diameter 9.0 mm 	<ul style="list-style-type: none"> 2 cores stranded as pair, 4 screened pairs to cable core (4x2xAWG24) Tinned 7-wire braided conductor with foam skin PE insulation Pair screening made from plastic-laminated foil Overall screening consisting of braiding made from tinned copper wires (85% degree of coverage) PVC outer sheath material Max. outer diameter 9.0 mm 	<ul style="list-style-type: none"> 2 cores stranded as pair, 4 screened pairs to cable core (4x2xAWG24) Tinned 7-wire braided conductor with foam skin PE insulation Pair screening made from plastic-laminated foil Overall screening consisting of braiding made from tinned copper wires (85% degree of coverage) PUR outer sheath material Max. outer diameter 9.0 mm 	<ul style="list-style-type: none"> 2 cores stranded as pair, 4 screened pairs to cable core (4x2xAWG24) Tinned 7-wire braided conductor with foam skin PE insulation Pair screening made from plastic-laminated foil Overall screening consisting of braiding made from tinned copper wires (85% degree of coverage) PVC outer sheath material Max. outer diameter 9.0 mm

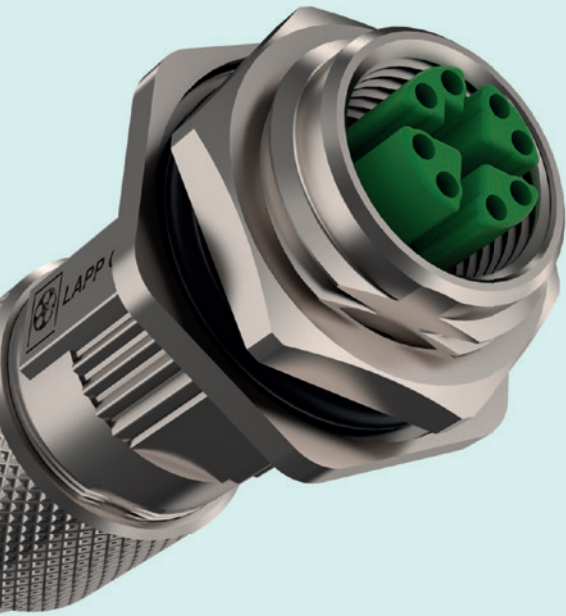

Copper connectors

RJ45 pin assignment (IEC 60603-7-51)

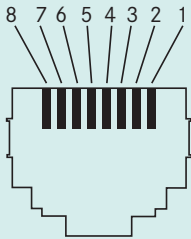

M12 pin assignment (IEC 61076-2-101)

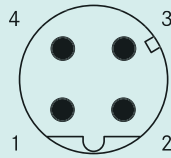

4-pin
D-coded
for Industrial
Ethernet

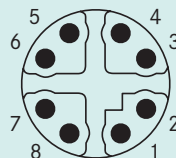

8-pin
X-coded
for Cat.6_A

Pin assignments

TIA 568-A	TIA 568-B	PROFINET®	RJ45	M12 D-coded	M12 X-coded
White/green	White/orange	Yellow	1	1	1
Green	Orange	Orange	2	3	2
White/orange	White/green	White	3	2	3
Blue	Blue	-	4		8
White/blue	White/blue	-	5		7
Orange	Green	Blue	6	4	4
White/brown	White/brown	-	7		5
Brown	Brown	-	8		6

Copper connectors

The PROFINET® guideline specifies various connector designs for the copper conductor connection system – both for cabling in protected areas such as in the control cabinet, where the lower protection class IP20 is required, and for cabling in the field with more demanding requirements for protection classes up to IP68.

Two standards have been established for connectors with respect to the transmission of data from Industrial Ethernet – RJ45 and M12. While RJ45 is most familiar from the world of IT, M12 connectors have been a fixture in the industrial environment for decades. The RJ45 elegantly solves the issue of 4-pin or 8-pin cabling with the same connector face. This enables the transmission of Fast Ethernet or even 10 Gbit Ethernet using a single connector.

In contrast, two different codings have established themselves among M12 connectors. For connection to a 4-pin cable,

a D-coded connector is used to achieve the transmission of up to 100 Mbit/s.

In order to achieve transmission rates of up to 10 Gbit/s, an 8-core cable is connected to an M12 connector with X-coding. The bandwidth is ensured by the screening cross that separates the four pairs from one another.

With respect to field mountable connectors, the main focus should be on ensuring that the connection process is as easy as possible and performed without the use of special tools where possible. In addition, the connectors should be able to connect to as many cables as possible. This means that they cover a broad spectrum of core cross-sections and diameters, conductor stranding and cable outer diameters.

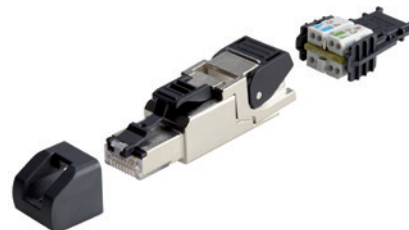

FIELD MOUNTABLE CONNECTORS

						
Product	M12 X-coded, IP67		RJ45 straight, Cat.5, Cat.6A, IP20		RJ45 angled, Cat.5, Cat.6A, IP20	
Article number	21700602/21700621/21700622		21700605/21700600/21700601		21700638/21700636/21700637	
	Min.	Max.	Min.	Max.	Min.	Max.
Cable outer diameter mm	5	9.7	5	9	5.5	10
Core outer diameter mm	0.85	1.6	1.0	1.6	1.0	1.6
AWG stranded wire, 7-wire	27	22	27	22	27	22
AWG solid	24	22	24	22	24	22
Ambient temperature in °C	-40	85	-40	85	-40	85
Housing material	Zinc die-cast		Zinc die-cast		Zinc die-cast	
Connection system	IDC		IDC		IDC	
Key features	Only two individual parts		Easy assembly thanks to twist-proof core manager 3-level cable support		Cable outlet possible in four different 90° steps	

Installation instructions



ASSEMBLING RJ45 CONNECTORS – DO IT YOURSELF IN A FEW SHORT STEPS

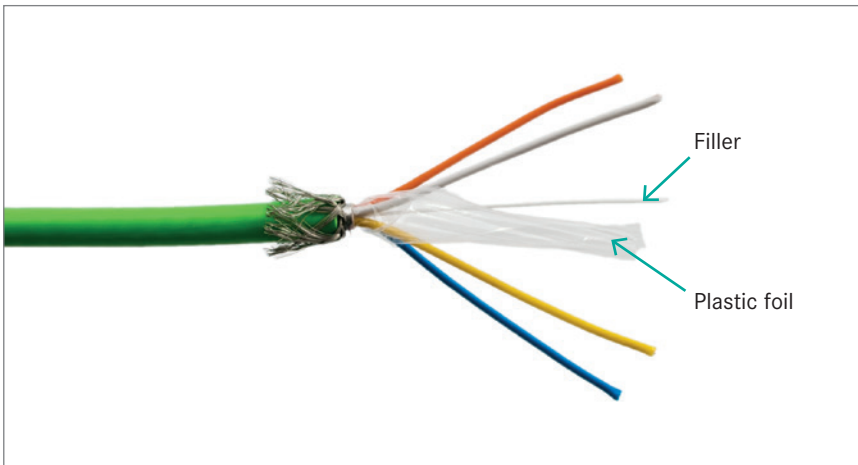

Preparing the cable

- Remove outer sheath and push back braided conduit
- Cut and remove the braided foil and inner sheath
- Remove filler and plastic foil

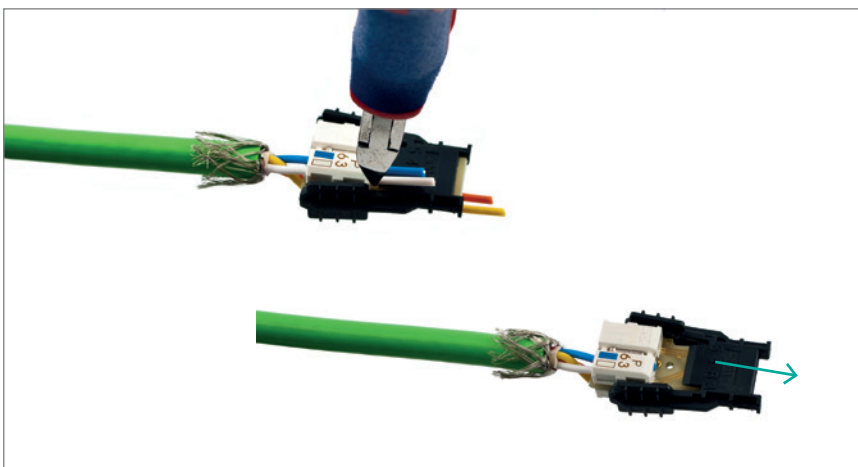

Contact with the wire manager

- Guide core pairs into the wire manager and press the wire manager
- First cut the wire such that they are flush, then remove the assembly aid

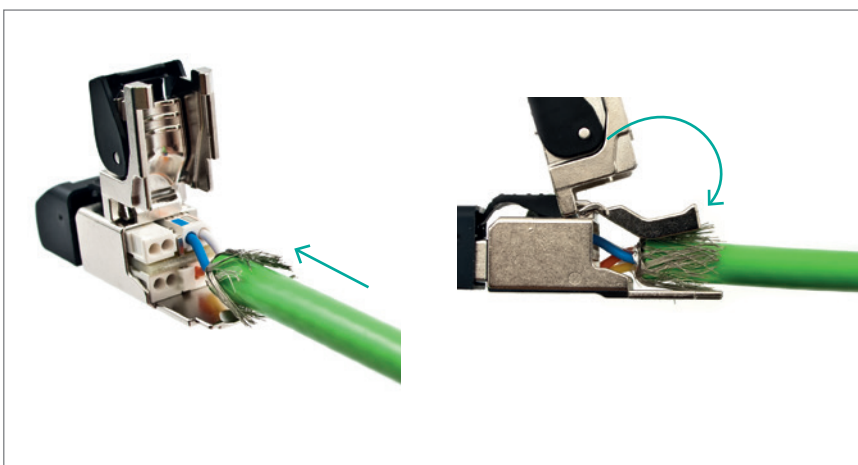

Guiding the wire manager into the housing

- Push in the wire manager according to the coding
- The braid cover can be used to move the wire manager to the end position
- Lock the housing parts in place and secure the cable support

Detailed installation instructions can be found on our website and are also available on request.



ASSEMBLING M12 X-CODED CONNECTORS – DO IT YOURSELF IN A FEW SHORT STEPS

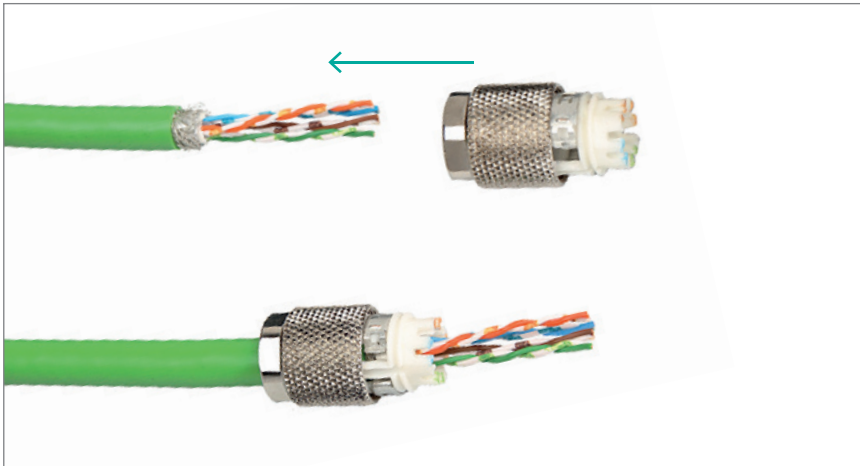

Preparing the cable

- Remove outer sheath and inner separating cross
- Guide the cable into the stuffer cap until the braided shield is positioned at the height of the braided clamps
- Press the braided clamps into the latching

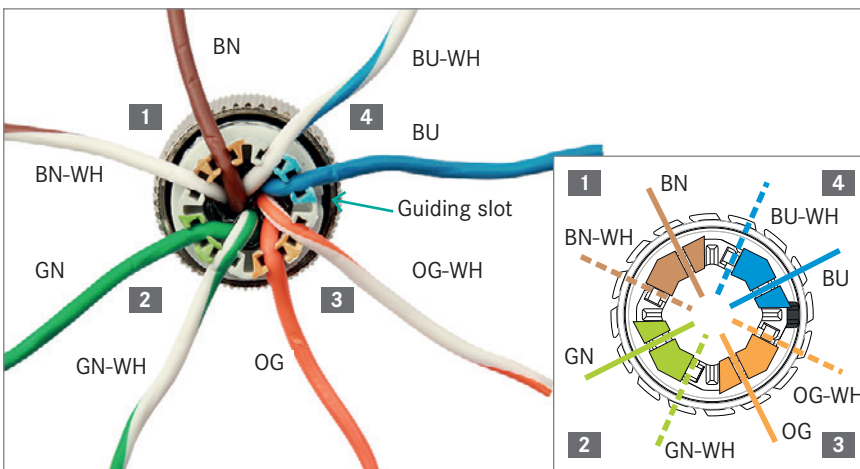

Positioning the cores in the stuffer cap

- Pay attention to the positioning of the cables in the cable stuffer and rotate the cables to adapt to the colour coding
- Twist on the core pairs and position these in the gaps in the stuffer cap
- Cut the cores such that they are flush with the stuffer cap

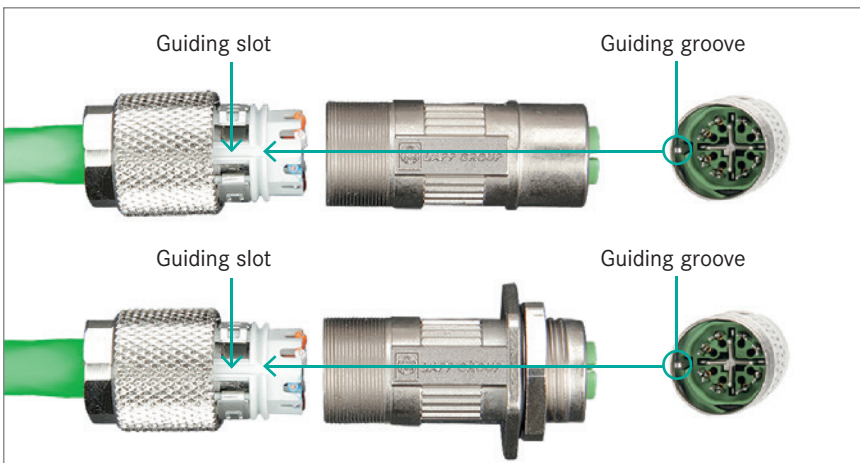

Joining the stuffer cap to the housing

- Align the guiding groove of the stuffer cap and the strip of the housing with one another
- Securely screw together the stuffer cap and the housing

Detailed installation instructions can be found on our website and are also available on request.

COPPER CABLES IN FOCUS

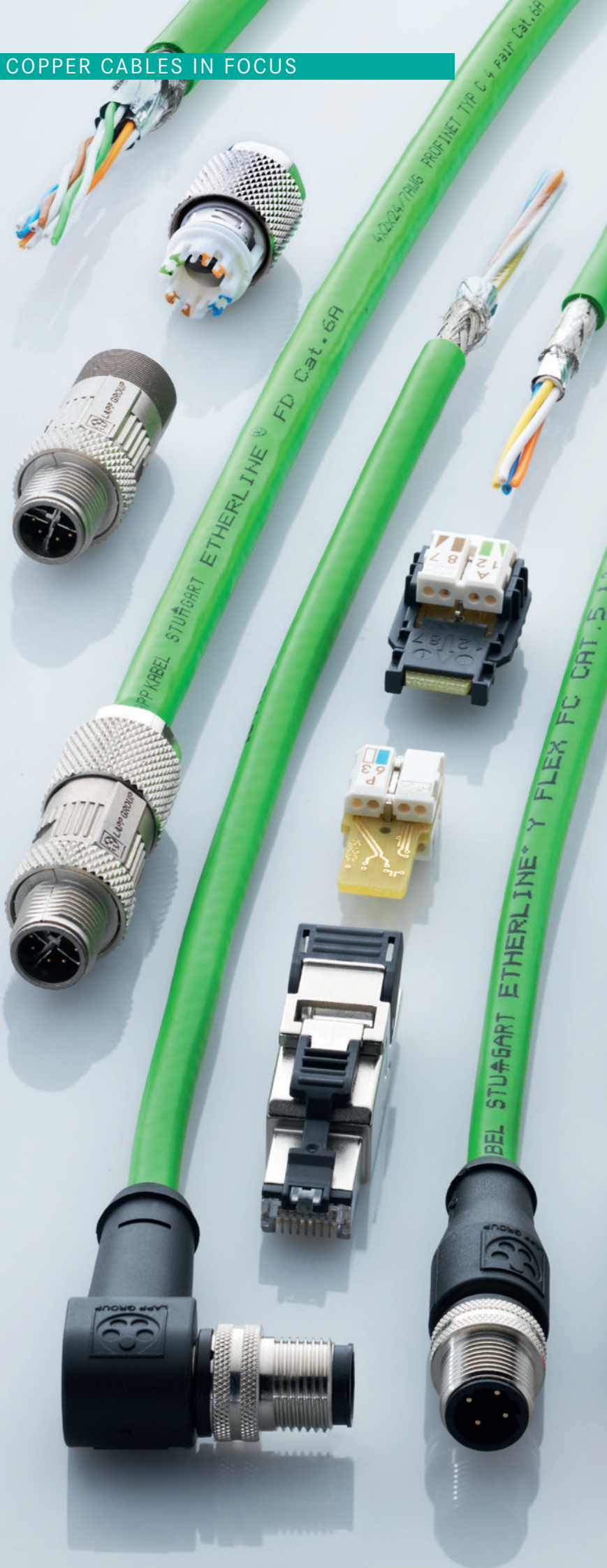

Industrial Ethernet connectors are available as field mountable designs or as overmoulded assemblies. These factory-tested products combine proven Lapp cable quality with high-quality connectors. All PROFINET® assemblies feature Lapp ETHERLINE® PROFINET® cables. UL approval also applies for all 2-pair assemblies of types A, B and C with M12 connectors in combination with the approved cables that are used.

With 360° shielding, the ETHERLINE® assemblies are protected against external electromagnetic interference and in turn do not affect their devices as a result of electrical interference.

Double extrusion ensures maximum sealing tightness and optimum appearance. Integrated vibration protection ensures even greater security.

Overmoulded assemblies help you save time if you connect the cables yourself, prevent differences in connection quality and even enable you to attain a higher level of sealing tightness than can be achieved using field mountable connectors.

Assembly selection overview

PROFINET® assemblies			Length in m	2-pair cables			4-pair cables			
				PROFINET®					FD	TORSION
				Type A	Type B	Type C				
			Article number	Article number	Article number	Article number	Article number			
Cable connection type	Connector to connector	M12 – M12 (straight)	1	2171001	2171025	2171049	2172001	2172101		
			2	2171002	2171026	2171050	2172002	2172102		
			3	2171003	2171027	2171051	2172003	2172103		
			5	2171004	2171028	2171052	2172004	2172104		
			10	2171005	2171029	2171053	2172005	2172105		
		20	2171006	2171030	2171054	2172006	2172106			
		M12 (angled) – M12 (straight)	1	2171013	2171037	2171061				
			2	2171014	2171038	2171062				
			3	2171015	2171039	2171063				
			5	2171016	2171040	2171064				
	10		2171017	2171041	2171065					
	M12 – RJ45 (straight)	1	2171165	2171215	2171265					
		2	2171166	2171216	2171266					
		3	2171167	2171217	2171267					
		5	2171168	2171218	2171268					
		10	2171169	2171219	2171269					
	RJ45 – RJ45 (straight)	1	2171179	2171229	2171279					
		2	2171180	2171230	2171280					
		3	2171181	2171231	2171281					
		5	2171182	2171232	2171282					
10		2171183	2171233	2171283						
Female to connector	M12 – M12 (straight)	20	2171170	2171220	2171270					
		1				2172029	2172129			
		2				2172030	2172130			
		3				2172031	2172131			
		5				2172032	2172132			
Connector to free cable end (OE)	M12 (straight) – OE	1	2171007	2171031	2171055	2172008	2172108			
		2	2171008	2171032	2171056	2172009	2172109			
		3	2171009	2171033	2171057	2172010	2172110			
		5	2171010	2171034	2171058	2172011	2172111			
		10	2171011	2171035	2171059	2172012	2172112			
		20	2171012	2171036	2171060	2172013	2172113			
	M12 (angled) – OE	1	2171019	2171043	2171067					
		2	2171020	2171044	2171068					
		3	2171021	2171045	2171069					
		5	2171022	2171046	2171070					
		10	2171023	2171047	2171071					
	RJ45 (straight) – OE	20	2171024	2171048	2171072					
		1	2171186	2171236	2171286					
		2	2171187	2171237	2171287					
		3	2171188	2171238	2171288					
		5	2171189	2171239	2171289					
		10	2171190	2171240	2171290					
	Female to free cable end	M12 (straight) – OE	20	2171191	2171241	2171291				
			1				2172171	2172178		
			2				2172172	2172179		
3						2172173	2172180			
5						2172174	2172181			
			10				2172175	2172182		
			20				2172176	2172183		
Cables used			Article number	Article number	Article number	Article number	Article number			
			2170893	2170886	2170894	2170484	2170483			

Connector finder



PROFINET® 2-PAIR UP TO 100 MBIT/S

Cables			Suitable connectors			
Application	Article number	Description	Application	Article number	Description	
4-pin type A for fixed installation	2170891	ETHERLINE® PN Cat.5e Y 2X2XAWG22	M12 plug, D-coded	22260820	AB-C4-M12MSD-SH	
	2170893	ETHERLINE® Y FC Cat.5				
	2170494	ETHERLINE® PN Cat.5e YY				
4-pin type B for flexible application	2170886	ETHERLINE® PN Cat.5 Y FLEX FC	M12 socket, D-coded	22261016	AB-C4-M12FSD-SH	
	2170890	ETHERLINE® PN Cat.5e FRNC FLEX FC				
	2170889	ETHERLINE® MARINE FRNC FC Cat.5				
4-pin type C for special application	Drag chain	2170894	ETHERLINE® FD P FC Cat.5	RJ45 connector, straight	21700605	ED-IE-AX-5-PN-20-FC
	Torsion	2170888	ETHERLINE® TORSION P Cat.5 AWM			
	Routing underground	2170496	ETHERLINE® Cat.5 ARM	RJ45 connector, angled	21700638	ED-IE-90-6A-PN-20-FC
	Outdoor installation	2170901	ETHERLINE® Y Cat.5e BK			
	Increased temperature range	2170636	ETHERLINE® Cat.5e 105 plus			



PROFINET® 4-PAIR UP TO 10 GBIT/S

Cables			Suitable connectors			
Application	Article number	Description	Application	Article number	Description	
8-pin type A for fixed installation	Cat.6 _A	2170466	ETHERLINE® Cat.6 _A H	M12 plug, X-coded	21700602	ED-IE-AX-M12X-6A-67-FC
		2170465	ETHERLINE® Cat.6 _A P			
		2170464	ETHERLINE® Cat.6 _A Y			
	Cat.7	2170476	ETHERLINE® H Cat.7 H	M12 socket, X-coded	21700621	ED-IE-AX-M12XF-6A-67-FC
		2170475	ETHERLINE® Cat.7 P			
		2170474	ETHERLINE® Cat.7 Y			
8-pin type B for flexible application	Cat.6 _A	2170930	ETHERLINE® PN Cat.6 _A Y FLEX 4x2x23/7	M12 socket, X coded, with flange	21700622	ED-IE-AX-M12XF-RM-6A-67-FC
		2170931	ETHERLINE® PN Cat.6 _A FRNC FLEX 4x2x23/7			
8-pin type C for special application	Drag chain, Cat.6 _A	2170485	ETHERLINE® FD Cat.6 _A 4X2X24/7AWG	RJ45 connector, straight, TIA568-B	21700601	ED-IE-AX-6A-B-20-FC
		2170484	ETHERLINE® FD P Cat.6 _A 4X2X24/7AWG			
	Torsion, Cat.6 _A	2170483	ETHERLINE® TORSION P Cat.6 _A 4X2XAWG24/7	RJ45 connector, angled, TIA568-A	21700636	ED-IE-90-6A-A-20-FC
		2170482	ETHERLINE® TORSION Y Cat.6 _A 4X2XAWG24/7			
RJ45 connector, angled, TIA568-B	21700637	ED-IE-90-6A-B-20-FC				

FIBRE OPTIC CABLES IN FOCUS

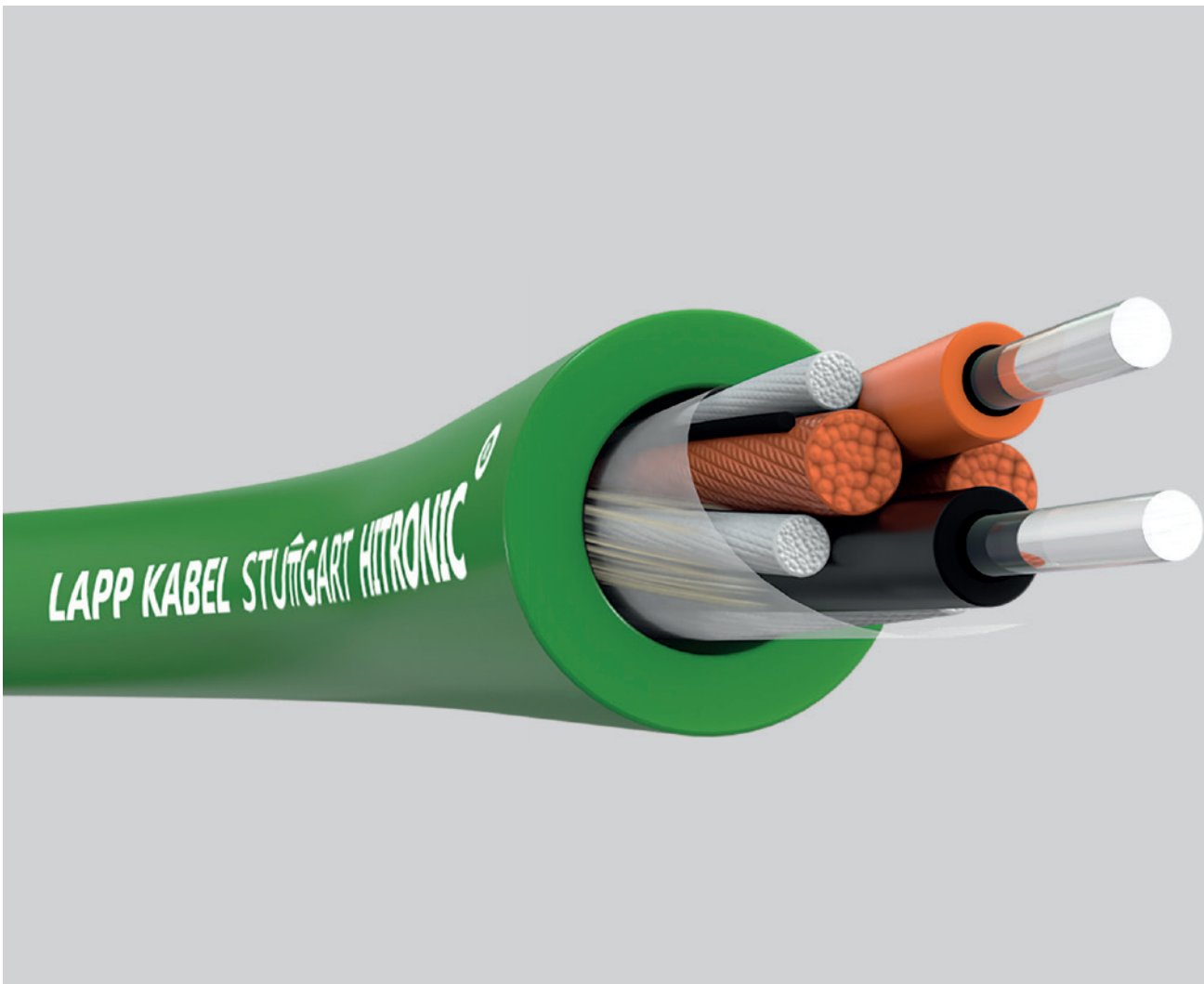



Fibre optic cables

The optical transmission of signals in fibre optic cables functions according to the principle of 'total reflection'. The reflection is attained by surrounding a light-conducting core with a sheath that is optically thinner – the light is totally reflected by the boundary surface of the sheath, enabling it to be guided through the fibre optic cable.

Although the principle of optical signal transmission has long been known, it has only been possible within the last 20 years for low-loss fibre optic cables to be developed, produced and used commercially. At a time when the demand for fast and secure communication networks is constantly growing, fibre optic cables are now an indispensable and irreplaceable communication medium.

The benefits of using fibre optic cables are as follows:

- High level of interception protection
- No EMC interference
- No EMC tests required
- Long distances covered
- No potential losses
- No crosstalk
- Low space requirement
- Low cable weight
- Can be installed in explosive environments

GENERAL TRANSMISSION CHARACTERISTICS OF FIBRE OPTIC CABLES

Fibre type/ wavelength	Maximum attenuation [dB/km]				Maximum transmission length [m]				Sheath colour code
	660 nm	850 nm	1300 nm	1550 nm	660 nm	850 nm	1300 nm	1550 nm	
POF 980 µm	160				100 Mbit/s: 60				
PCF 200 µm	10.0	8.0			100 Mbit/s: 550				
GOF MM 62.5 µm OM1		3.5 (3.0)	1.5 (0.7)			100 Mbit/s: 550 1 Gbit/s: 275 10 Gbit/s: 33	100 Mbit/s: 2,000 1 Gbit/s: 550 10 Gbit/s: 300		Orange
GOF MM 50 µm OM2		3.5 (2.5)	1.5 (0.7)			100 Mbit/s: 550 1 Gbit/s: 550 10 Gbit/s: 82	100 Mbit/s: 2,000 1 Gbit/s: 550 10 Gbit/s: 300		Orange
GOF MM 50 µm OM3		3.5 (2.5)	1.5 (0.7)			1 Gbit/s: 1,000 10 Gbit/s: 300 40 Gbit/s: 100 100 Gbit/s: 100	1 Gbit/s: 550 10 Gbit/s: 300		Aqua
GOF MM 50 µm OM4		3.5 (2.5)	1.5 (0.7)			1 Gbit/s: 1,100 10 Gbit/s: 550 40 Gbit/s: 150 100 Gbit/s: 150	1 Gbit/s: 550 10 Gbit/s: 300		Violet
GOF SM 9 µm OS2 (G652.D)			0.40 (0.35)	0.40 (0.21)			1 Gbit/s: 5,000 10 Gbit/s: 10,000	1 Gbit/s: 80,000 10 Gbit/s: 40,000	Yellow

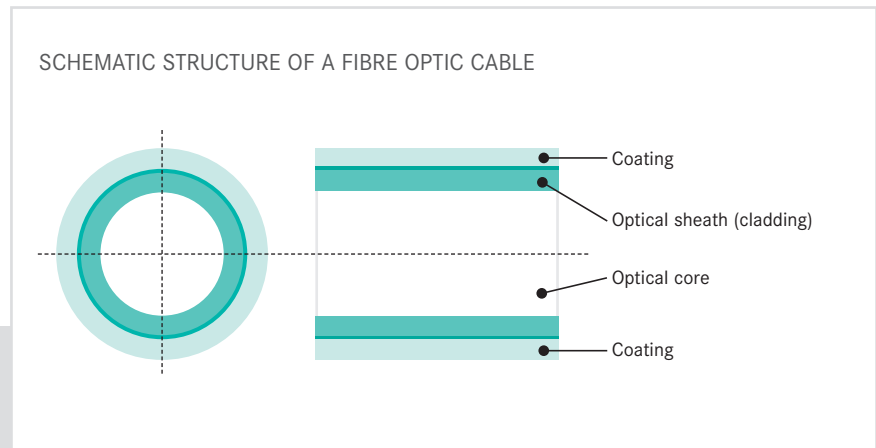

PROFINET[®] transmission via fibre optic cables

In the case of communication via fibre optic cables, the data signal that is to be transferred is converted from an electrical signal into an optical signal by an active component (e.g. media converter, switch) prior to transfer. This optical signal can then be transferred along further paths within a fibre optic cable without significant losses.

A fibre optic cable is a dielectric and transparent transmission medium. To put it simply, it is a light-conducting medium that features the following simplified structure (see above graphic).

The core and sheath each consist of a dielectric material, with the core material featuring a higher optical index of refraction than the sheath material positioned above it.

Within the core area, the optically emitted signal is guided between the media boundaries of the core and sheath area by means of reflection and refraction, enabling it to be transferred. The unit consisting of the core and sheath (fibre) is protected by a coating that is applied over it.

The dielectric medium is non-metallic and non-conductive, offering the following benefits compared with transfer using a metallic medium:

- No interference from external fields/ electromagnetic interference
- No grounding problems
- No distance-related signal losses resulting from electrical effects such as inductivity, capacities and resistances
- Lightweight design

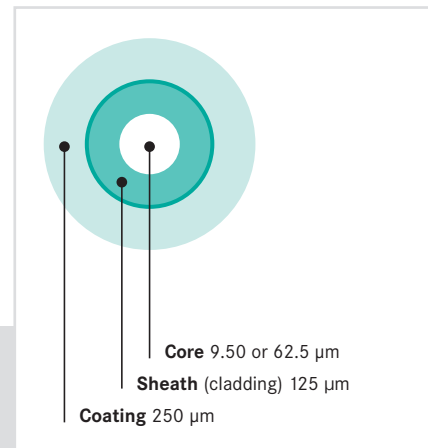
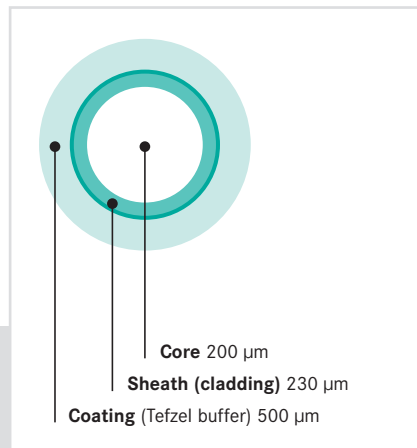
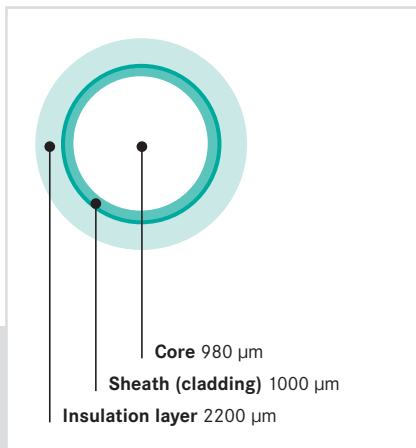

Different fibre optic cables in the PROFINET[®] range

Plastic fibre optic cables

- Compliant with IEC 61918 and IEC 61784-5-3/PNO specification
- Compliant with IEC 60793 Optical Fibres and IEC 60794 Optical Fibre Cables
- POF – plastic optical fibre
- Core and sheath made from plastic
- Core diameter: 980 µm; sheath diameter: 1000 µm
- Brief description: P980/1000 (P for plastic fibre, core diameter and sheath diameter)
- Core diameter: 2.2 mm (fibre with attached sheathing made from PE, PA or PVC)
- Cable design with 2 cores (duplex), colour-coded black and orange with printed arrows
- Cable colour: green
- Cable length up to 50 m

Glass fibres with plastic outer sheath

- Compliant with IEC 61918 and IEC 61784-5-3/PNO specification
- Compliant with IEC 60793 Optical Fibres and IEC 60794 Optical Fibre Cables
- PCF – plastic clad fibre
- Core made from glass, sheath made from plastic
- Core diameter: 200 µm; sheath diameter: 230 µm
- Brief description: K200/2300 (K for PCF structure, core diameter and sheath diameter)
- Core diameter: 500 µm (plastic sheath)
- Strain relief, non-metallic, aramide fibre yarns
- Single-cable element: 2.2 mm (core with strain relief and sheath)
- Cable design with two single-cable elements (duplex), colour-coded black and orange with printed arrows
- Cable colour: green
- Cable length up to 100 m

Glass fibres

- Compliant with IEC 61918 and IEC 61784-5-3/PNO specification
- Compliant with IEC 60793 Optical Fibres and IEC 60794 Optical Fibre Cables
- GOF – glass optical fibre
- Core and sheath made from glass
- Differentiation between multi-mode fibre (MM) and single-mode fibre (SM)
- Core diameter MM 50 µm or 62.5 µm, SM 9 µm; sheath diameter 125 µm
- Brief description of MM: G50/125 or G62.5/125 (G for multi-mode gradient index fibre, core diameter, sheath diameter)
- Brief description of SM: E9/125 (E for single-mode fibre, core diameter, sheath diameter)
- Initial protective sheath: 250 µm (plastic sheath)
- Core diameter: 500 µm (plastic sheath)
- Strain relief, non-metallic, aramide fibre yarns
- Single-cable element: 2.9 mm (core with strain relief and sheath)
- Cable design with two single-cable elements (duplex), colour-coded black and orange with printed arrows
- Cable colour: green
- Cable length: depends on fibre type and application (up to 30 km)



All the fibre optic cables featured here are robust round cables. Their dimensions and structure make them suitable for direct connector assembly. See the 'Connectors' section with regard to this topic. This means that the cables are easy to install in the field and are easy to connect according to the fibre type. If the exact application is already known, the use of pre-assembled cables simplifies the commissioning procedure and thereby helps save time.

Lapp is your perfect partner for pre-assembled PROFINET® cables – all you need to do is get in touch with us.

There is a diverse range of available cable types: due to the different applications and requirements, it is often possible to choose between a number of different cables for PROFINET® application types B and C. These normally differ in terms of the material and the structure of the outer sheath.

Selecting the sheath material for applications

- **PVC sheath design**
for standard applications in an industrial environment
- **PUR sheath design**
for high mechanical or chemical stress
in an industrial environment

Fibre optic cable application classes according to PNO

- **Type B**
for stationary installation or flexible use
- **Type C**
for special applications such as permanent flexing (drag chain), vibration or torsion

Note: all cable constructions (applies to type B and C) contain two fibres (duplex structure).

PROFINET® fibre optic cables

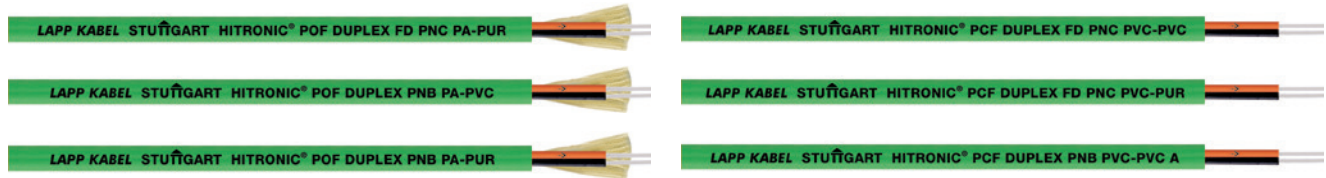

HITRONIC® POF DUPLEX

Benefits

- Optical signal transmission up to 70 m
- Easy to handle
- No interference from external fields
- No grounding problems
- Suitable for direct connector assembly

Application range

- Plastic fibre-optic cable for optical signal transmission in industrial applications
- PROFINET®/Industrial Ethernet
- Up to 100 Mbit/s: max. length 50 m

Design

PROFINET® type B:
for fixed installation



HITRONIC® POF
DUPLEX PNB PA-PUR
Article number: 28051002



HITRONIC® POF
DUPLEX PNB PA-PVC
Article number: 28052002

PROFINET® type C:
for flexing applications (drag chain)



HITRONIC® POF
DUPLEX FD PNC PA-PUR
Article number: 28351002

HITRONIC® PCF DUPLEX

Benefits

- Optical signal transmission up to 500 m
- Easy to handle
- No interference from external fields
- No grounding problems
- Suitable for direct connector assembly

Application range

- PCF DUPLEX cable for optical signal transmission in industrial applications
- PROFINET®/Industrial Ethernet
- Up to 100 Mbit/s: max. length 100 m

Design

PROFINET® type B:
for fixed installation



HITRONIC® PCF
DUPLEX PNB PVC-PVC A
Article number: 28055702
(cable design with c(UL)us listing type OFNG according to UL 1651 for USA and Canada)



HITRONIC® PCF
DUPLEX PNB PVC-PVC
Article number: 28052702

PROFINET® type C:
for flexing applications (drag chain)



HITRONIC® PCF
DUPLEX FD PNC PVC-PUR
Article number: 28351702



HITRONIC® PCF
DUPLEX FD PNC PVC-PVC
Article number: 28352702

PROFINET® glass fibre cables available on request:

- HITRONIC® GOF DUPLEX PNB: Fibre type 62.5/125 OM1, 50/125 OM2 or 9/125 OS2
- HITRONIC® GOF DUPLEX PNC: Fibre type 62.5/125 OM1, 50/125 OM2 or 9/125 OS2

Fibre optic connectors for PROFINET® applications according to PNO

In terms of connectors, a distinction is made with regard to the fibre type and the application.

Connector for fibre type POF

- Very easy to handle. Configurable by means of crimp or clamp connection
- Connector with inner bore > 1 mm at a fibre diameter of 1000 µm and pin diameter (ferrule) of 2.5 mm
- Tailored tool set for straightforward field configuration

Connector for fibre type PCF

- Easy to handle. Configurable by means of crimp and cleave technology
- Connector with inner bore > 230 µm at a fibre diameter of 230 µm and pin diameter (ferrule) of 2.5 mm
- Tailored tool set for straightforward field configuration

Connector for fibre type GOF

- Handling requires existing knowledge. Assembly by means of bonding and polishing process
- Connector with inner bore > 125 µm at a fibre diameter of 125 µm and pin diameter (ferrule) of 2.5 mm or 1.25 mm (depending on connector type)
- Assembly by qualified staff
- The use of pre-assembled cables is recommended



SCHEMATIC SIZE COMPARISON OF CONNECTOR PIN (2.5 MM) AND HOLE (POF - PCF - GOF)

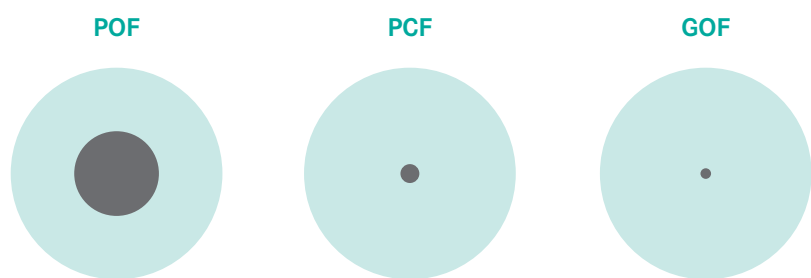

When comparing the different connector holes with regard to the fibre diameter, it becomes apparent that these are not interchangeable with one another. In other words, a PCF connector cannot be used for a POF cable. A PCF connector cannot be used for a POF cable as the fibre geometries and parameters are not compatible with one another.



Connector type SC-RJ

- Corresponds to IEC 61754-24
- For POF, PCF and GOF
- Push-pull connector
- SFF measurements (small form factor, compact measurements)
- Pin diameter (ferrule) 2.5 mm
- IP20



Connector type LC

- Corresponds to IEC 61754-20
- For GOF single-mode and multi-mode
- Push-pull connector
- SFF measurements (small form factor, compact measurements)
- Pin diameter (ferrule) 1.25 mm
- IP20



Connector type ST(BFOC)

- Corresponds to IEC 61754-2
- BFOC – bayonet fibre optic connector
- For POF, PCF and GOF
- Circular connector
- Bayonet locking
- Pin diameter (ferrule) 2.5 mm
- IP20



Optical M12 connection system

Available on request as assembled cable.

General distinction between applications

- In the control cabinet or protected area – connectors with protection class IP20
- Outside the control cabinet or under harsh environmental conditions – connectors with protection class IP6X

Connector types in the protected area:

- SC-RJ for fibre types POF and PCF
- LC for fibre type GOF
- Exception for existing applications and installations: ST(BFOC) and SC-DUPLEX

Connector types outside the protected area:

- SC-RJ connector in protected IP6x housing (SC-RJ push-pull connector) and optical M12 duplex connector upon discussion

PROFINET® fibre optic connectors for on-site assembly



SC-RJ CONNECTOR FOR POF/PCF CABLE

- The connector type SC-RJ is available for POF and PCF cables on request
- For POF cables featuring crimp design
- For PCF cables featuring crimp and cleave assembly design
- Connector set contains all necessary individual components

ST(BFOC) CONNECTOR FOR POF CABLE

- The connector type ST(BFOC) can be used for previously installed plants – **not for new installations**
- Connectors for two different assembly options:
 - Crimp design for fixed and permanent connection
 - Clamp design for quick connection and multiple uses (e.g. for connection attempts and the laboratory environment)
- Connector set contains all necessary individual components
- Including anti-kink protection for a cable diameter of 2.2 mm (coloured black and red) and dust protection cap

Design

Crimp version

POF connector ST(BFOC) crimp
 Article number: 29125099 (PU, 4 pcs.)
 Article number: 29125098 (PU, 50 pcs.)

Clamp version

POF connector ST(BFOC) clamp
 Article number: 29120099 (PU, 4 pcs.)
 Article number: 29120098 (PU, 50 pcs.)

ST(BFOC) CONNECTOR FOR PCF CABLE

- The connector type ST(BFOC) can be used for previously installed plants – **not for new installations**
- Connectors for the crimp and cleave assembly technology, tailored for use with PCF; the fibres are securely clamped and separated using a special tool (see assembly set)
- Connector set contains all necessary individual components
- Including anti-kink protection for a cable diameter of 2.2 mm (coloured black and red) and dust protection cap

Design

Clamp version

PCF connector ST(BFOC) clamp 2.2
 Article number: 29125799 (PU, 4 pcs.)
 Article number: 29125798 (PU, 50 pcs.)

Assembly sets for PROFINET® fibre optic connectors



ASSEMBLY SET FOR SC-RJ CONNECTOR

- Assembly set for SC-RJ connectors; POF and PCF design; available on request
- For POF in crimp assembly technology
- For PCF in crimp and cleave assembly technology
- Sets each contain all necessary tools for connector assembly



ASSEMBLY SET FOR ST(BFOC) POF CONNECTOR

- Tailored assembly set with all necessary tools for assembling the ST(BFOC) crimp connector design

Set contains

Crimping tool, core stripper, polishing papers, polishing wheel, cutter

Assembly set

POF connector ST(BFOC)
Article number: 29500002



ASSEMBLY SET FOR ST(BFOC) PCF CONNECTOR

- Tailored assembly set with all necessary tools for assembling the ST(BFOC) clamp connector design with crimp and cleave assembly technology

Set contains

Stripping and fibre cleaving tool, Kevlar scissors, knife, microscope

Assembly set

PCF connector ST(BFOC)
Article number: 29500702

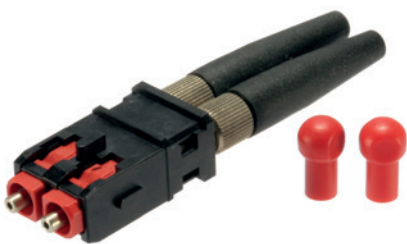

Connector/cable finder

PROFINET® components			Connectors	Crimp design		Clamp design			
			Design	POF		POF		PCF	
			Article number	29125099	29125098	29120099	29120098	29125799	29125798
Cables	Design	Article number	Description	POF connector ST(BFOC) crimp 2.2/4 pcs.	POF connector ST(BFOC) crimp 2.2/50 pcs.	POF connector ST(BFOC) clamp 2.2/4 pcs.	POF connector ST(BFOC) clamp 2.2/50 pcs.	PCF connector ST(BFOC) clamp 2.2/4 pcs.	PCF connector ST(BFOC) clamp 2.2/50 pcs.
PROFINET® FO POF	Type B	28051002	HITRONIC® POF DUPLEX PNB PA-PUR	X	X	X	X		
		28052002	HITRONIC® POF DUPLEX PNB PA-PVC	X	X	X	X		
	Type C	28351002	HITRONIC® POF DUPLEX FD PNC PA-PUR	X	X	X	X		
PROFINET® FO PCF	Type B	28055702	HITRONIC® PCF DUPLEX PNB PVC-PVC A					X	X
		28052702	HITRONIC® PCF DUPLEX PNB PVC-PVC					X	X
	Type C	28351702	HITRONIC® PCF DUPLEX FD PNC PVC-PUR					X	X
		28352702	HITRONIC® PCF DUPLEX FD PNC PVC-PVC					X	X
Assembly set	POF	29500002	Assembly set POF connector ST(BFOC)	X	X				
	PCF	29500702	Assembly set PCF connector ST(BFOC)					X	X

X = compatible

Lapp also supplies assembled PROFINET® cables on request according to your needs.

APPENDIX



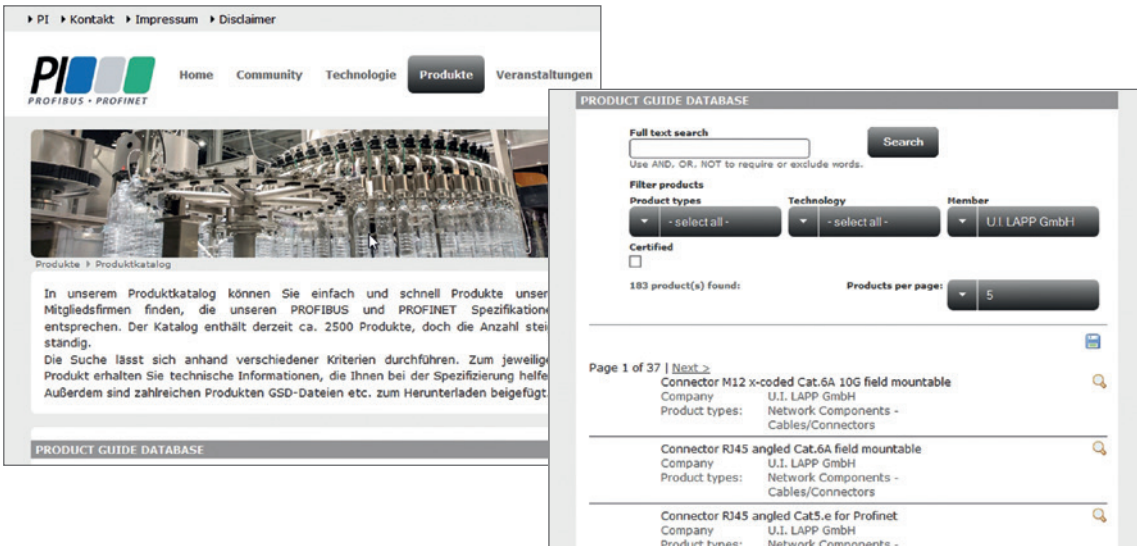

Manufacturer’s declaration and PROFIBUS and PROFINET® User Organization (PNO)

The primary objective of PROFINET® is a component approach and compatibility of components between different manufacturers. In order to ensure this compatibility, every member and/or every manufacturer of these components is obligated to submit a manufacturer’s declaration of conformity according to PROFINET® guidelines and specifications.

The Lapp Group develops its products according to the strict specifications of the ‘PROFINET® Cabling and Interconnection Technology Guideline’ and submits a manufacturer’s declaration for the components accordingly.

The Lapp Group is not only a member and a manufacturer of PROFINET®-compliant products, but is also actively involved in the standardisation of cabling and connection solutions.

In addition, all products for PROFINET® and for PROFIBUS can be found on the website of the User Organization:

www.lappgroup.com/products

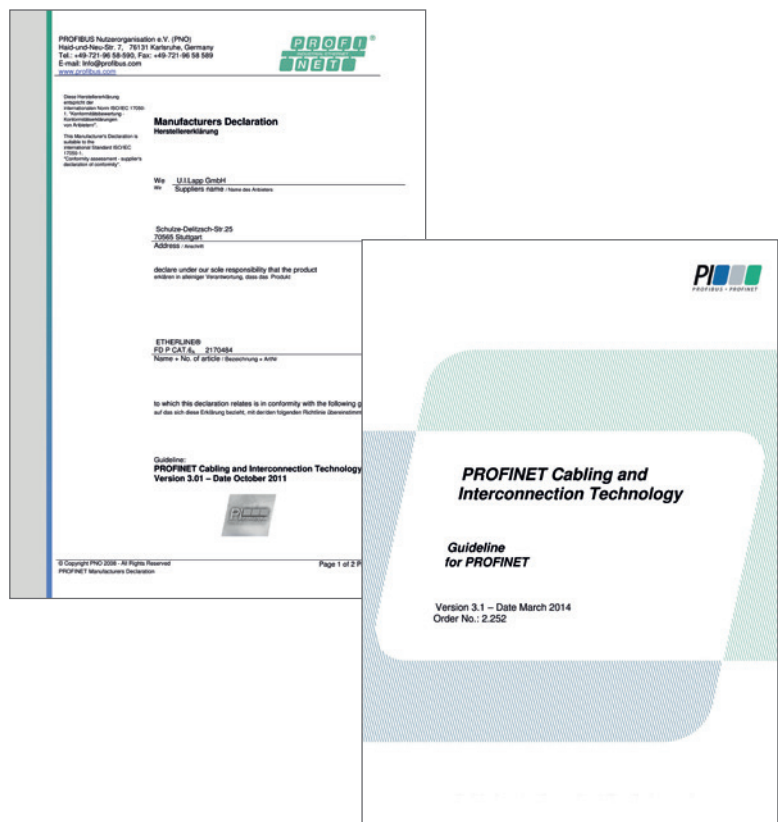

The following applies for the use of our products

The conformity of our products to the relevant European directives and compliance with the provisions contained therein shall be indicated by the CE marking.

The safety of our products is closely associated with how they are used. A knowledge of and adherence to the respective international/national standards of use

(e.g. DIN VDE 0100; 0298) are mandatory. There are particular risks if installed improperly. This applies to all our products/items:

Processing is only to be done by an authorised electrician! Otherwise, there is the risk of an electric shock or a fire ignited by electric current!

Safety

Without exception, our products are tested for application safety in accordance with defined standards and our own regulations, which complement the standards. Relevant legal requirements and safety regulations are also observed. Provided due care and attention is paid, the possibility of product-specific danger to the user may thus reasonably be excluded. Where products are used carelessly or incorrectly, however, considerable danger to persons and the environ-

ment may arise. For this reason, our cables must only be processed and/or used responsibly by trained electricians or specialists. This catalogue contains general information for the application of each product. Independent of such information, the application standards DIN VDE 0298 and DIN VDE 0891 for cables will apply. Excerpts from these standards, as well as complementary selection and application tables, design and installation guidelines, are con-

tained in the tables in the appendix to this catalogue. Our machines and installation tools are - where necessary - designed in accordance with the machine guidelines and display the CE identification mark. It must be noted, however, that our machines and installation tools must only be used by trained specialist personnel and for the purpose for which they were designed. ©Copyright by U.I. Lapp GmbH. Reprinting or reproduction of the text or the illustrations

may be made only with written approval and with correct indication of source. We reserve the right to make modifications to our products, especially those based on technical improvements or continued development. All illustrations and numerical data etc. are therefore without warranty and are subject to change.

ÖLFLEX®

UNITRONIC®

ETHERLINE®

HITRONIC®

EPIC®

SKINTOP®

SILVYN®

FLEXIMARK®

Follow the Lapp Group on



Terms of Trade:

Our general conditions of sale
can be downloaded from our website
www.lappgroup.com/terms



www.lappgroup.com

To contact your local Lapp Group representative
please visit www.lappgroup.com/worldwide