

EPIC® SENSORS
Threaded thermowells

Features

- fitted to application with thread, no welding required
- AISI 316L as delivery material, other materials on request
- length according to customer specific need
- external thread for process or enclosure attachment
- used to house MI cable structured sensor element
- HEX key shape for tightening purposes
- customer specific threads available
- 3D step models available on request.

Typical applications

- energy and power plant technology
- process industry
- chemical industry
- machinery and vessel construction
- manufacturing industry.



Technical data

Materials	AISI 316L / EN1.4404, max. temperature +550 °C, temporarily +600 °C, Other materials available on request
Thread	G, R, metric and NPT, Other threads available on request
Diameter	Ø9 mm, Other diameters available on request
Quality certificate	ISO 9001:2015 and ISO 14001:2015 issued by DNV

Drawing

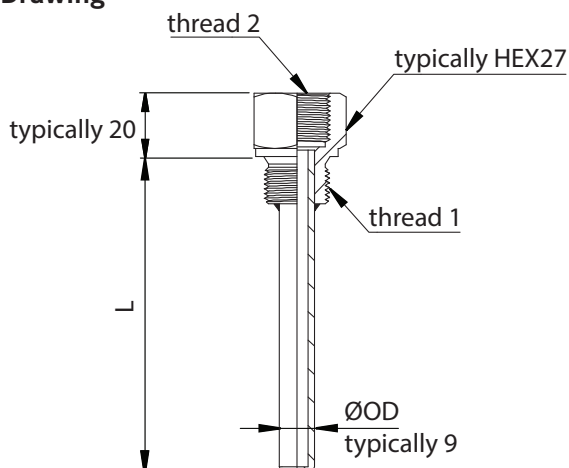

Product code key

Example code: TPIE — G½ / G½ — 9 / 100 — X

