

EPIC® SENSORS

TRACE HEATING SENSOR
TYPE W-M-TRACE, 2xW-M-TRACE
DATA SHEET 23

**INSTALLATION INSTRUCTIONS
AND USER MANUAL****Table of contents**

Product description and intended use.....	2
Temperatures, measuring.....	3
Temperatures, ambient.....	3
Temperatures, Ex e components.....	4
Sensors:	4
Enclosures:.....	4
Code key	5
Technical data.....	6
Materials.....	6
Dimensional drawing.....	7
Installation instructions and example	8
Installation of accessories	9
Pipe fittings = pipe clamps:	9
Tightening torques	9
Pt100; connection terminals.....	10
Pt100; connection wiring.....	11
Pt100; measuring current.....	11
Type label of standard versions	12
Serial number information	12
Ex e data (only for cable sensor components with Ex e approval).....	13
Ex e certificates and Ex markings of cable sensor components.....	13
Ex e type label of cable sensor components.....	14
EU Declaration of Conformity	15
Manufacturer contact information	15
Document history	15

Product description and intended use

Sensor types W-M-TRACE and 2xW-M-TRACE (resistance, RTD) are temperature sensors for trace heating applications, constructed with one or two mineral insulated sensors and a terminal box.

Sensors are intended for measuring trace heated pipe surfaces. The 2-sensor version can be used when a separate temperature measurement is wanted for limit/alarm purpose, leaving the other sensor clearly for control circuits.

The sensor elements can be designed long enough to give needed distance between heat source (pipe) and box/enclosure. Standard lengths are 1000 mm or 2000 mm. Sensor element protection tube material can be chosen, and element length can be produced according to customer needs.

Measuring elements are mineral insulated (MI) elements, which are bendable. Elements are RTD elements, standard versions are 4-wire Pt100 sensors. Tailored versions are produced on request.

NOTE! **Also available with ATEX approved, protection type Ex e components.**
Please see section *Ex data*.

When used as part of an installation, subsequent approval of the entity is required.

EPIC® SENSORS temperature sensors are measuring devices intended for professional use. They should be mounted by professionally capable installer who understands the installations surroundings. The worker should understand mechanical and electrical needs and safety instructions of the object installation. Suitable safety gear for each installation task must be used.

Temperatures, measuring

Allowed measuring temperature range for cable sensor tip is:

- Standard (non-Ex), sensor type W-M-302 -200...+450, temporarily +550 °C
- Ex e, cable sensor type WT-MI-302-...-EX -60...+550 °C

Temperatures, ambient

Allowed ambient temperatures for Ex cable sensors; please see section *Temperatures, Ex e components*.

Allowed ambient temperature range for enclosure is:

- Standard box -40...+80 °C
- Ex enclosures please see Ta classes in section *Technical data*.

Allowed ambient temperature range for terminal connectors is:

- Standard -55...+85 °C

Temperatures, Ex e components

NOTE! W-M-TRACE assembly can be equipped with Ex e approved components.

When used as part of an installation, subsequent approval of the entity is required.

Sensors:

If Ex e version cable sensors are used, the sensor types are: WT-MI-302-...-.

Allowed measuring temperature range for sensor tip is: -60...+550 °C.

With these Ex e cable sensor types, specific conditions apply according to the ATEX certificates.

For type WT-MI-302-6-...-EX, certificates EESF 18 ATEX 049 Issue 1 and EESF 18 ATEX 051 Issue 1:

The temperature classification of the sensor (550 °C, T1 - T6) is determined by the ambient temperature of the installation place.

Maximum ambient temperature is 550 °C for the sensor head and 125 °C for the connection terminals of the sensor cable.

Enclosures:

Allowed ambient temperature ranges:

- for Ex e enclosure please see *Technical data* for Ta classes.
- for terminal connectors -55...+85 °C

Please see also section *Ex data*.

Code key

Product code key

Example code: W — M — TRACE — 6 / 1000 — 4 — A — EX — X

W	= Pt100 resistance thermometer
2xW	= 2 x Pt100 resistance thermometer
M-TRACE	= mineral insulated trace heating sensor (constant in code)
3, 6	= outer diameter of sensor element (ØOD) [mm]
1000	= sensor element length, L [mm]
4,3,2	= Pt100 wire count
A,B	= Pt100 accuracy class, (class A as standard delivery)
empty	= no Ex e -approval
EX	= Ex e -approved components
X	= additional details on the text line

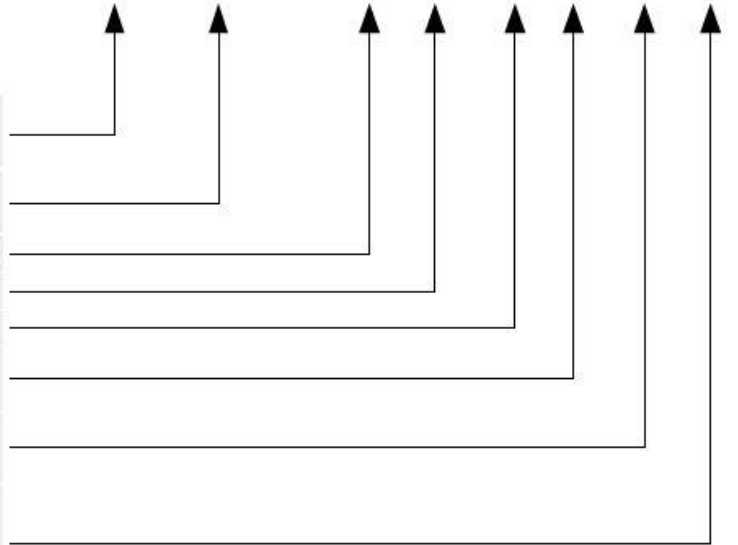

Technical data

Materials	AISI 316L, maximum temperature +450 °C, temporarily +550 °C, other materials on request
Tolerances Pt100 (IEC 60751)	A tolerance $\pm 0.15 + 0.002 \times t$, operating temperature -100...+450 °C B tolerance $\pm 0.3 + 0.005 \times t$, operating temperature -196...+600 °C B 1/3 DIN, tolerance $\pm 1/3 \times (0.3 + 0.005 \times t)$, operating temperature -196...+600 °C B 1/10 DIN, tolerance $\pm 1/10 \times (0.3 + 0.005 \times t)$, operating temperature -196...+600 °C
Temperature range Pt100	-60...+450 °C, temporarily +550 °C
Sensing element classification	II 2 GD Ex e T1-T6 Ex tD A21 IP66 T 60 °C T amb (max.) -40...+125/550 °C
Length	1000 or 2000 mm as standard delivery, other lengths on request
Diameter	3 or 6 mm, other diameters on request
Enclosure dimensions	160x160x90 mm (WxHxD)
Enclosure material	Glass-reinforced polyester as standard delivery, other materials on request
Enclosure classification	II 2 GD Ex e IIC T6 Gb (Ta = -65...+40°C, +55°C, +60°C or +65°C) Ex e IIC T4 Gb (Ta = -65°C...+90°C) Ex Ib IIC T6 Gb (Ta = -65°C...+40°C, +55°C, +60°C or +65°C) Ex Ib IIC T4 Gb (Ta = -65°C...+90°C) Ex tb IIIC T85°C Db (Ta = -65°C...+40°C, +55°C, +60°C or +65°C) Ex tb IIIC T100°C Db (Ta = -65°C...+90°C)
Box temperature range	-40...+80 °C
Cable glands	Product with 2 sensing elements: 1 x cable gland, M25x1.5, for cable diameters 6-13 mm Product with 1 sensing element: 2 x cable gland, M25x1.5, for cable diameter 6-13 mm
Approvals	Available with Ex e approved components, subsequent approval of the entity is required.
Quality certificate	ISO 9001:2015 and ISO 14001:2015 issued by DNV
IP rating	IP66 or IP67, other IP rating on request

Materials

These are the standard materials of components for the sensor types W-M-TRACE, 2xW-M-TRACE.

- Sensor element / MI cable sheet AISI 316L
- Enclosure Glass-Reinforced Polyester GRP
- Cable glands Polyamide with CR/Special Elastomer seal
- Contact terminals Polyamide PA66

Other materials can be used on request.

Dimensional drawing

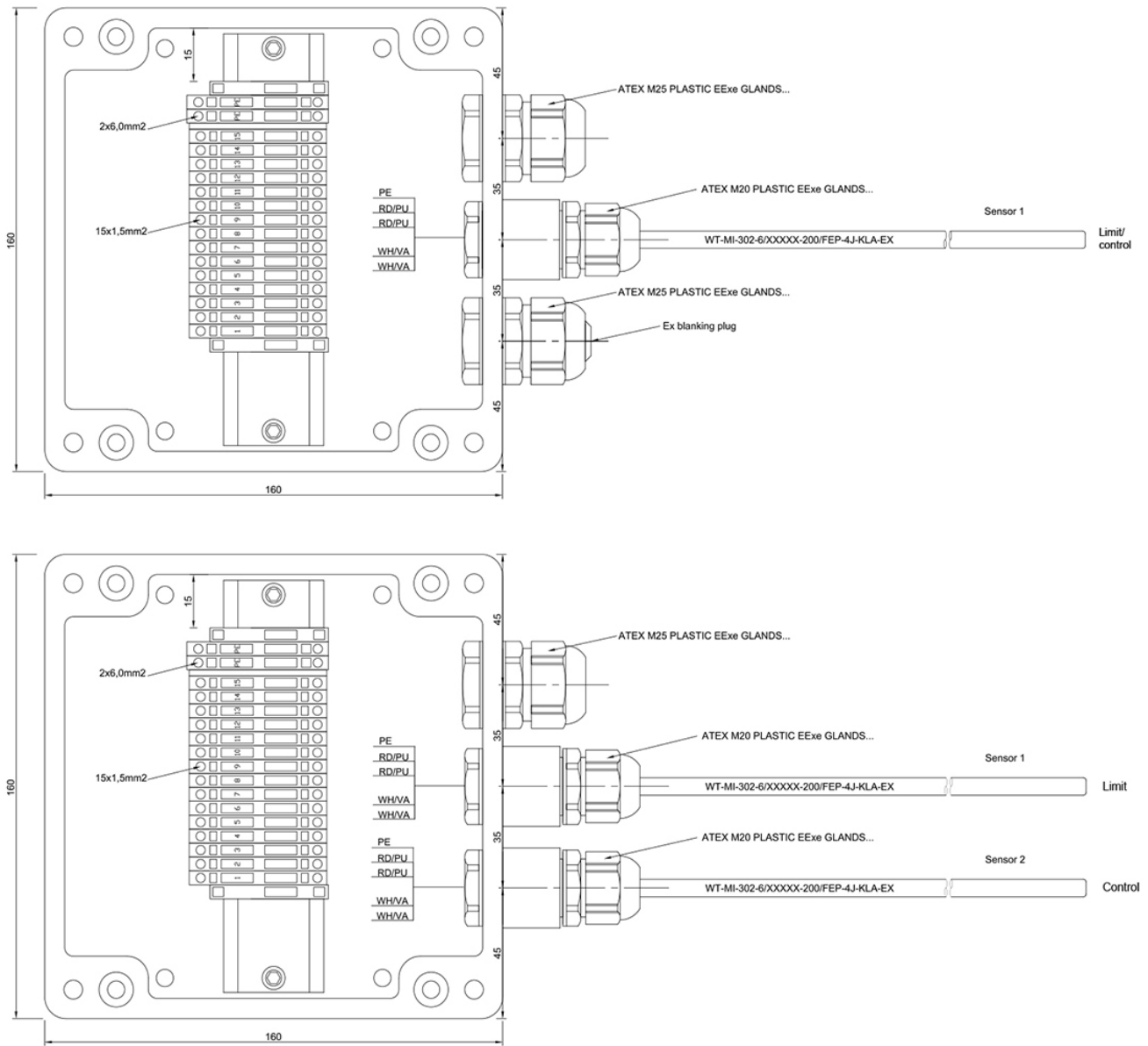

This example drawing above is presenting an application with Ex e approved components. For details about Ex applications, please see section *Ex data*.

Installation instructions and example

Before any installation, make sure the target process/machinery and site are safe to work!

Installation phases:

- Install the box/enclosure on wall, considering the length of sensors.
- During installation, remember the MI element minimum bending radius is $2x \text{ } \varnothing\text{OD}$ of the element.
- Do not bend the tip (30 mm) of RTD sensing elements, it might destroy the resistor inside.
- Bend the sensor elements to align them with the pipe surface.
- Mount the sensor securely on pipe with pipe clamps or cable ties or similar accessories.
- Mount the pipe isolation if needed.
- Make sure there is no excess bending force loading the sensing element.

Image below: this example shows a sensor installed on trace heated process pipe.



Installation of accessories

Pipe fittings = pipe clamps:

There are stainless steel (1.4401) pipe clamp (hose clamp) components available as accessories.

Installation phases:

- Select a suitable clamp size according to the pipe diameter.
- Or select a separate, 1 m long strap part, and cut it in pieces of suitable lengths. Separate clamp parts for the strap can be ordered according to the need. Insert a clamp part to one end of the band.
- Apply the strap around the pipe, leaving the sensor element under the strap.
- Tighten the strap by twisting the screw clockwise, to give a secure thermal connection between sensor and pipe surface.

The components available are:

Product number	Type	Strap length/width	Material
915589	Pipe clamp	16-27/12MM	1.4401
1125786	Pipe clamp	25-40/12MM	1.4401
1125787	Pipe clamp	32-50/9MM	1.4401
1026077	Pipe clamp	50-70/12MM	1.4401
1228601	Pipe clamp	70-90/12MM	1.4401
5120444	Pipe clamp	90-110/12MM	1.4401
5120446	Pipe clamp	110-130/12MM	1.4401
5120448	Pipe clamp	130-150/12MM	1.4401
920556	Pipe strap	1METER/12MM	1.4401
920559	Pipe strap clamp	12MM	1.4401



Tightening torques

Use only tightening torques allowed in applicable standards of each thread size and material.

Pt100; connection terminals

In the terminal box / enclosure free wire ends of sensors are available, but they are not connected to terminals, to give the customer freedom of choosing terminals.

Pt100 Connections

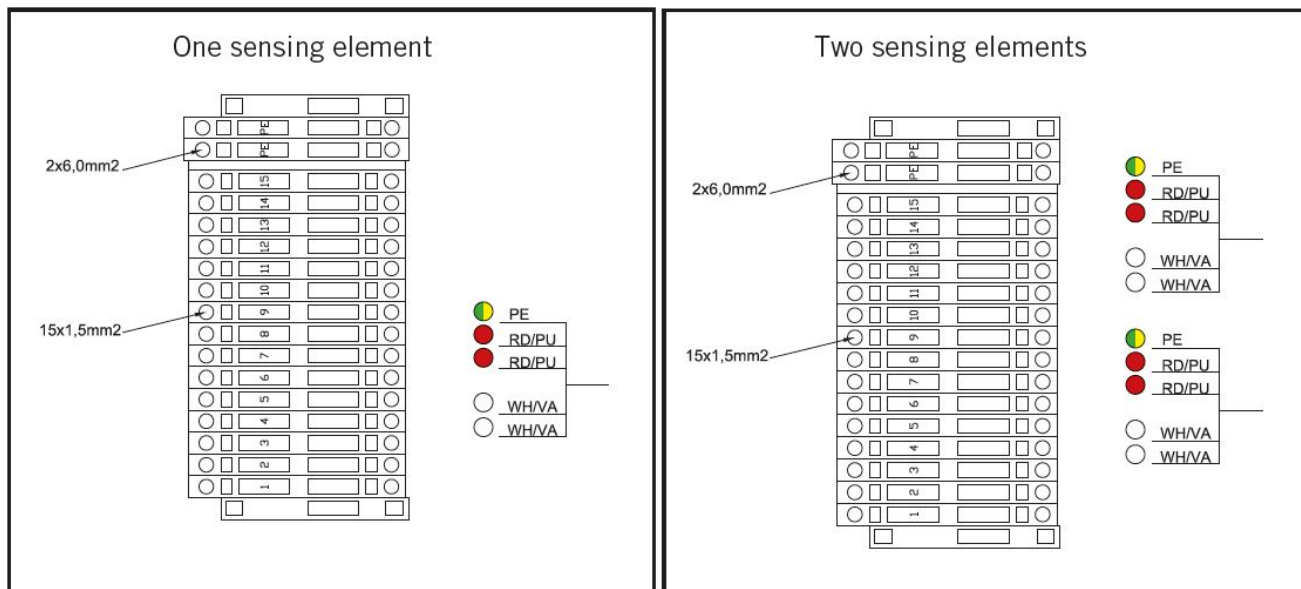

Wires are not connected, connection can be realized according to customer specification.

Pt100; connection wiring

Image below: These are the connection colors of Pt100 resistor connections, according to standard EN 60751.

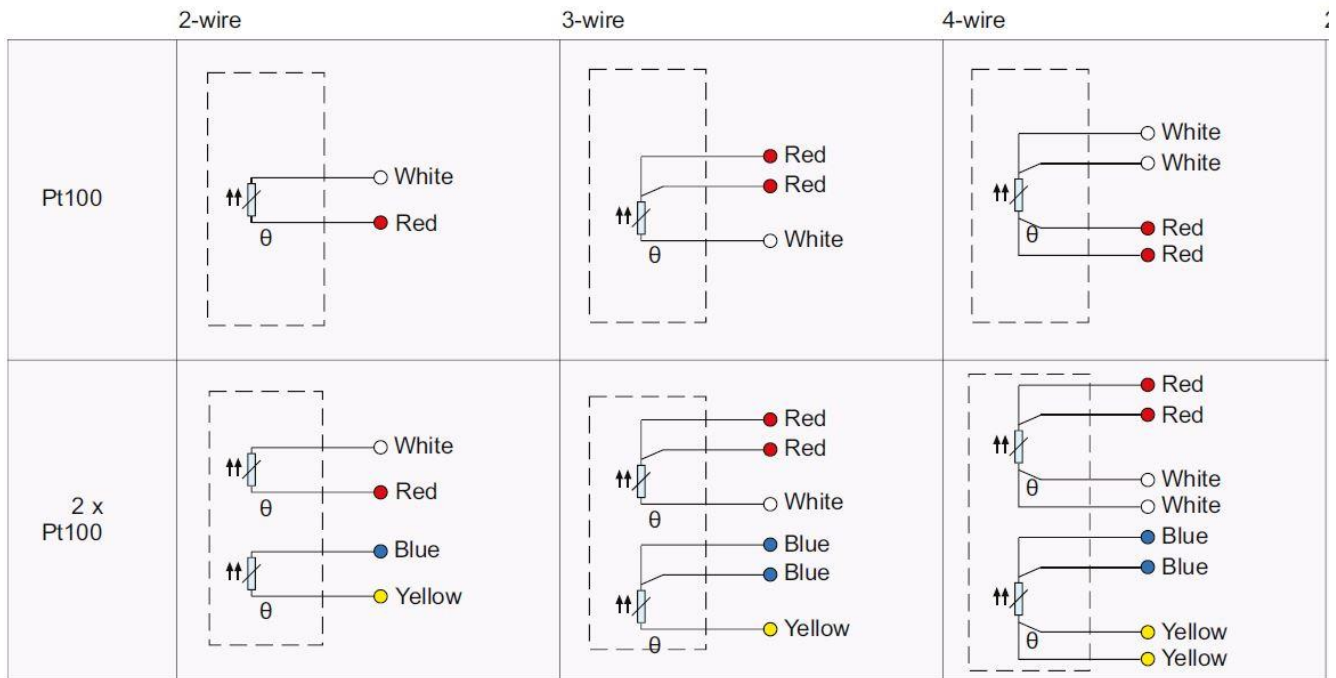

Other connections on request.

Pt100; measuring current

The highest allowed measuring current for Pt100 measuring resistors depends on resistor type and brand.

Normally the recommended maximum values are:

- Pt100 1 mA
- Pt500 0,5 mA
- Pt1000 0,3 mA.

Do not use higher measuring current. It will lead to false measurement values and might even destroy the resistor.

Type label of standard versions

Each sensor has a type label attached to it. It is a moisture and wear proof industrial grade sticker, with black text on white label. This label has printed information of trade name, web page, type code, CE-mark, product number and serial number, including production date. For these sensors manufacturer contact information is printed on a separate label.

Image below: Example of a non-Ex sensor type label.

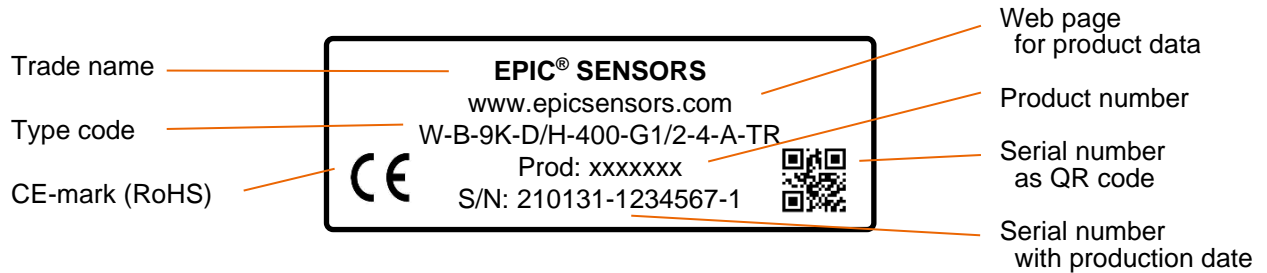

Serial number information

Serial number S/N is always printed on type label in the following form: yymmdd-xxxxxxx-x:

- yymmdd production date, e.g. “210131” = 31.1.2021
- -xxxxxxx production order, e.g. “1234567”
- -x sequential ID number within this production order, e.g. “1”

Ex e data (only for cable sensor components with Ex e approval)

If the trace heating sensor assembly W-M-TRACE is constructed with Ex e components, the cable sensor types are WT-MI-302-...-EX.

These Ex e cable sensor types are available with ATEX and EAC Ex approvals. The approved types are special versions, with type designation ending with -EX. Special data for use in Ex e applications is given in certificates.

Ex certificates and Ex markings of cable sensor components

Type Certificate number	Issued by	Applicable area	Marking
WT-MI-302-6-...-EX			
ATEX EESF 18 ATEX 049X, EESF 18 ATEX 051X	Eurofins Expert Services Oy, Finland, Notified Body Nr 0537	Europe	Ex II 2GD Ex e II T1-T6 Ex tD A21 IP66 T+60°C Tamb: -40...+125°C/+550°C
EAC Ex № EAЭC RU C- FI.AA71.B.00130-19	Lenpromexpertiza OOO, Russia	Eurasian Customs Union (Belarus, Kazakhstan, Russia)	1 Ex e IIC T6...T1 Gb X Ex tb IIIC T60°C Db X

For certificate copies and special Ex e product data, please visit:

<https://www.epicsensors.com/en/products/temperature-sensors/exe-extb-temperature-sensors/>

NOTE! When used as part of an installation, subsequent approval of the entity is required.

Ex e type label of cable sensor components

NOTE! These Ex e type labels are attached on and they only apply for cable sensor elements, which are used as components.

For **ATEX Ex e** -approved **WT-MI-302-...-EX** cable sensor Ex e versions there is more information on the label, according to applicable standards.

Image below: Example of an ATEX Ex e approved cable sensor type label.

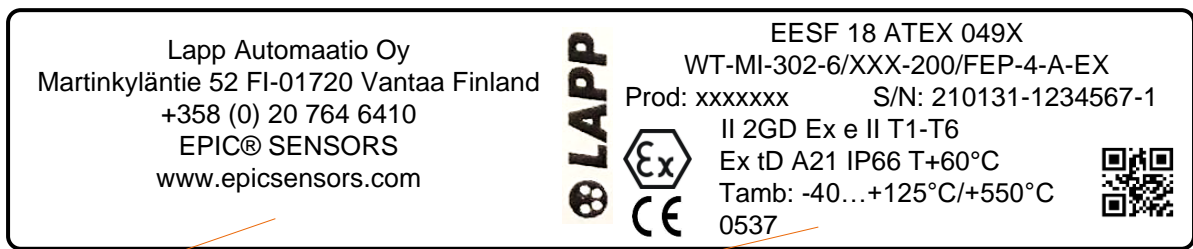

Manufacturer contact information. For some sensor types, this may also be printed on a separate label for practical reasons.

Ex certificate number(s)
 Type code
 Product number Serial number with production date
 Ex-mark (ATEX) Ex markings
 CE-mark (ATEX and RoHS) Serial number as QR code
 Notified body number
 Special technical values (if needed)

For **EAC Ex e** approved **WT-MI-302-...-EX** cable sensor versions, exported to Eurasian Customs Union area, there is a special type label.

Image below: Example of an EAC Ex-approved cable sensor type label.

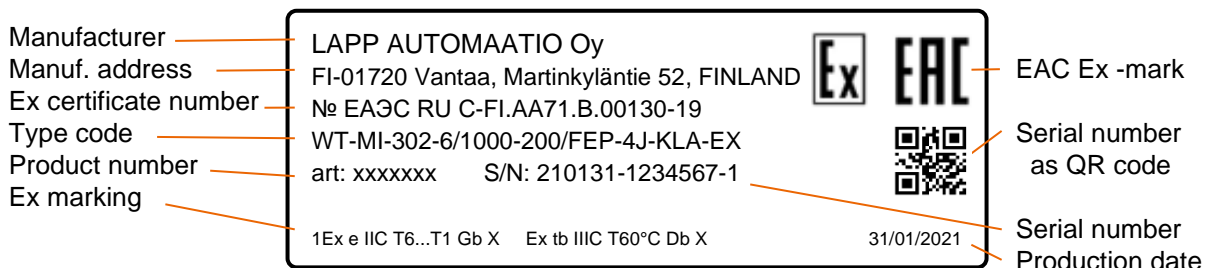

EU Declaration of Conformity

The EU Declaration of Conformity, declaring products' conformance to the European Directives, is delivered with products or sent on request.

Manufacturer contact information

Manufacturer HQ main office:

Lapp Automaatio Oy
Street address Martinkyläntie 52
Postal address FI-01720 Vantaa, Finland

Production site and logistics:

Lapp Automaatio Oy
Street address Varastokatu 10
Postal address FI-05800 Hyvinkää, Finland

Phone (sales) +358 20 764 6410

Email epicsensors.fi.lav@lapp.com
Https www.epicsensors.com

Document history

Version / date	Author(s)	Description
20230707	LAPP/VeTe	Text corrections.
20220822	LAPP/JuPi	Telephone number update
20220401	LAPP/JuPi	Original version

Although every reasonable effort is made to ensure the accuracy of the content of the operating instructions, Lapp Automaatio Oy is not responsible for the way the publications are used or for possible misinterpretations by end users. The user must ensure that she or he has the latest edition of this publication.

We reserve the right to make changes without prior notice. © Lapp Automaatio Oy