

## EPIC® SENSORS

SILICONE PATCH SENSOR WITH CABLE  
TYPE T-SIL-PATCH / W-SIL-PATCH  
DATA SHEET 24

## INSTALLATION INSTRUCTIONS AND USER MANUAL



### Table of contents

Product description and intended use.....	2
Temperatures, measuring.....	3
Temperatures, ambient.....	3
Code key.....	4
Technical data.....	5
Materials.....	5
Dimensional drawing.....	6
Installation instructions.....	7
Pt100; connection wiring.....	8
Pt100; measuring current.....	8
TC; connection wiring.....	9
TC; non-grounded or grounded types.....	9
TC; thermocouple cable standards (color table).....	10
Type label of standard versions.....	11
Serial number information.....	11
EU Declaration of Conformity.....	12
Manufacturer contact information.....	12
Document history.....	12

## Product description and intended use

Sensor types T-SIL-PATCH (thermocouple, TC) and W-SIL-PATCH (resistance, RTD) are silicone patch sensors with cable for surface temperature measurement.

Sensors are intended for quick and easy installation in various surface measurement applications. Sensor element is covered with a flexible silicone patch which can be attached in many ways to surface to be measured. As an option the silicone patch can be delivered with 2-sided adhesive aluminum foil tape with good thermal conductivity on measuring surface.

Elements can be TC or RTD elements, standard versions are K-type thermocouple (for T-SIL-PATCH) and 4-wire Pt100 (for W-SIL-PATCH). Wire and cable length and materials can be chosen.

Tailored versions are produced on request.

EPIC® SENSORS temperature sensors are measuring devices intended for professional use. They should be mounted by professionally capable installer who understands the installations surroundings. The worker should understand mechanical and electrical needs and safety instructions of the object installation. Suitable safety gear for each installation task must be used.

## Temperatures, measuring

Allowed measuring temperature range for sensor tip (silicone sensor head, patch) is:

- With Pt100 -40...+180 °C
- With TC -40...+180 °C

NOTE! Model 40x15x3: Allowed maximum temperature for heat shrink tubing on sensor end is +125 °C.  
Please see *Dimensional drawing*.

## Temperatures, ambient

Allowed maximum ambient temperature for wires or cable, according to cable type, is:

- SIL = silicone, max. +180 °C
- FEP = fluoropolymer, max. +205 °C
- GGD = glass silk cable/metal braid jacket, max. +350 °C
- FDF = FEP wire insulation/braid shield/FEP jacket, max. +205 °C
- SDS = silicone wire insulation/braid shield/silicone jacket, only available as 2 wire cable, max. +180 °C
- TDT = fluoropolymer wire insulation/braid shield/ fluoropolymer jacket, max. +205 °C
- FDS = FEP wire insulation/braid shield/silicone jacket, max. +180 °C
- FS = FEP wire insulation/silicone jacket, max. +180 °C
- CON = no cable, individual single wires, FEP wire insulation, max. +205 °C

NOTE! Model 40x15x3: Allowed maximum temperature for heat shrink tubing on sensor end is +125 °C.  
Please see *Dimensional drawing*.

Make sure the process temperature is not too much for the cable or heat shrink tube.

## Code key

Example code: W – SIL – PATCH – 40X15X3 – 5000 / SIL – 4 – A – Y – X

W	= Pt100 resistance thermometer
2xW	= 2 x Pt100 resistance thermometer
T	= thermocouple
2xT	= 2 x thermocouple
SIL-PATCH	= silicone patch sensor (constant in code)
40X15X3	
68X43X8	= silicone element size [mm]
5000	= cable or wiring length, CL [mm]
CON, SIL, FEP, GGD, FDF, TDT, SDS, FDS, FS	= cable material (for more information, look technical data on first page of the datasheet)
4,3,2	= Pt100 wire count
K,N,J	= thermocouple type
A,B	= Pt100 accuracy class, (class A as standard delivery)
1,2,3	= thermocouple accuracy class, (class 1 as standard delivery)
Y	= with aluminum foil on installation surface
N	= no aluminum foil
X	= additional details on the text line
	_____
	_____

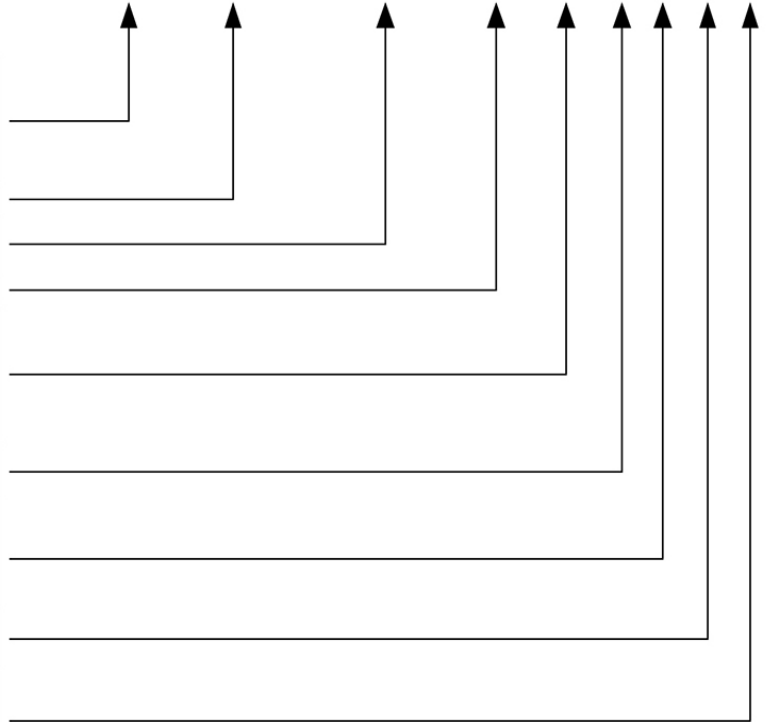



Dimensional drawing

Model 40x15x3

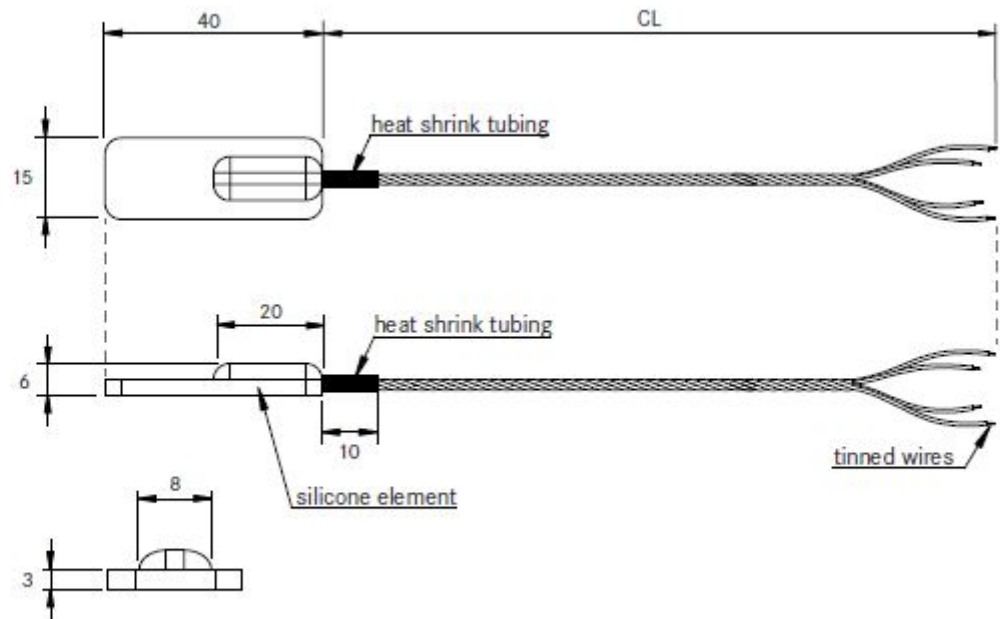

Model 68x43x8

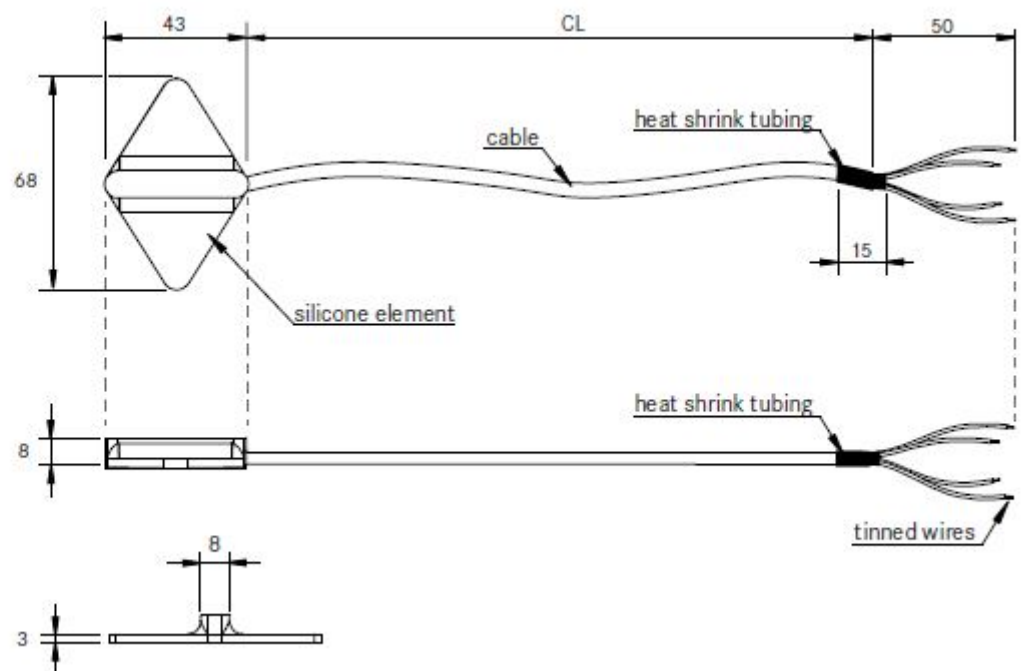

## Installation instructions

Before any installation, make sure the target process/machinery and site are safe to work!

Make sure the cable type matches the temperature and chemical requirements of the site.

### Installation phases:

- Apply the silicone patch on a surface to be measured.
- Use a pipe clamp or cable tie or similar, to fix patch closely to surface.
- Or apply the patch with 2-sided adhesive aluminum foil (delivery option)
- Or, depending on surface material, the patch can be screwed or nailed down through the patch outer ends.
- Or weld a special fixing part on the measured surface, then insert the sensor patch in.
- Make sure there is no excess bending or pulling force loading the cable.
- Mount extra strain relief, e.g. cable tie, for cable, if necessary.

Image below: this example shows sensor installed with a pipe clamp, and with a welded fixing accessory.

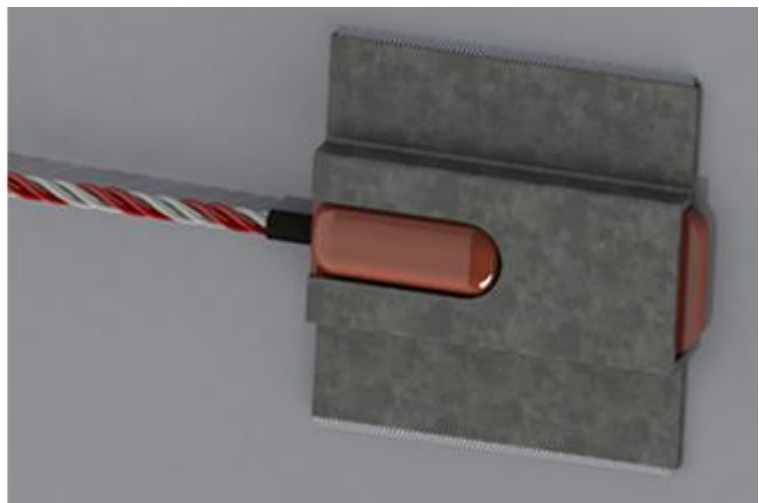

## Pt100; connection wiring

Image below: These are the connection colors of Pt100 resistor connections, according to standard EN 60751.

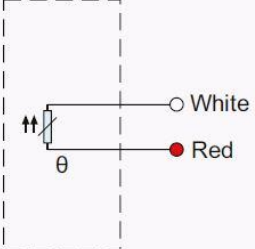
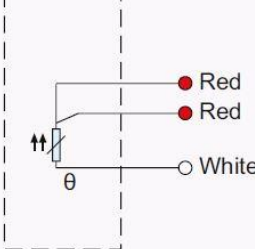
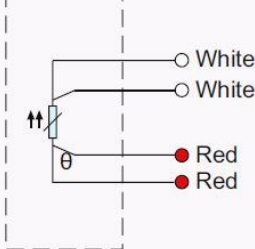
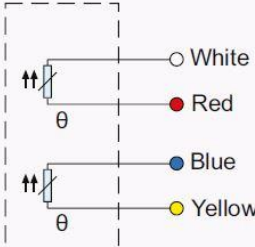
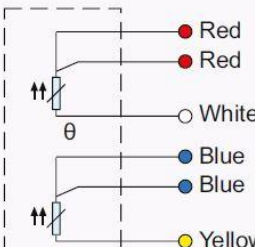
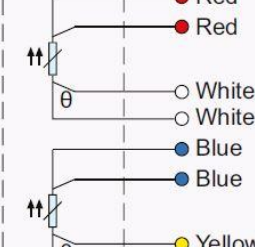
	2-wire	3-wire	4-wire
Pt100			
2 x Pt100			

Other connections on request.

## Pt100; measuring current

The highest allowed measuring current for Pt100 measuring resistors depends on resistor type and brand.

Normally the recommended maximum values are:

- Pt100            1 mA
- Pt500            0,5 mA
- Pt1000          0,3 mA.

Do not use higher measuring current. It will lead to false measurement values and might even destroy the resistor.



## TC; connection wiring

Image below: These are the connection colors of TC types J, K and N.

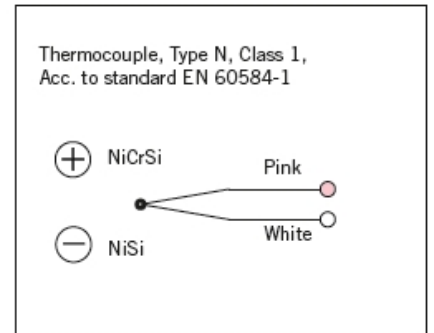
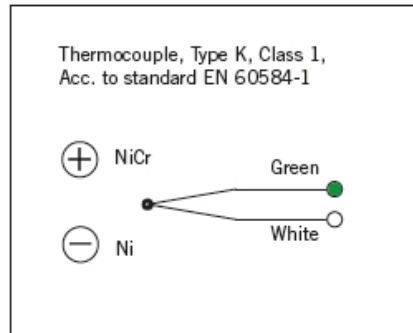
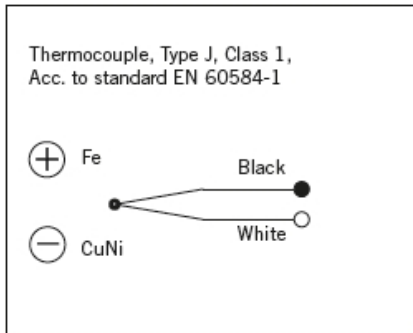

Other types on request.

## TC; non-grounded or grounded types

Normally the thermocouple sensors are non-grounded, which means the protective tube / MI cable sheath is not connected to the thermo material hot junction, where two materials are welded together.

In special applications also grounded types are used.

NOTE! Non-grounded and grounded sensors cannot be connected to same circuits, make sure you are using the right type.

Image below: Non-grounded and grounded structures in comparison.

**Non-grounded TC**

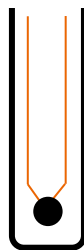

















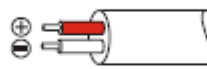

Thermo material hot junction and protective tube / MI cable sheath are galvanically isolated from each other.

**Grounded TC**



Thermo material hot junction has galvanic connection with protective tube / MI cable sheath.

TC; thermocouple cable standards (color table)

New standards:	IEC 60584-3	DIN EN 60584	ISA MC 96.1
Thermo Type	IEC 584	DIN 43714	ANSI MC 96.1
NiCr-Ni / K KCA: Fe-CuNi	 + green/ - white Jacket: green	 + red/ - green Jacket: green	 + yellow/ - red Jacket: yellow
Fe-CuNi / L		 + red/ - blue Jacket: blue	
Fe-CuNi / J	 + black/ - white Jacket: black		 + white/ - red Jacket: black
Pt10Rh-Pt / S SCA: E-Cu/A-Cu	 + orange/ - white Jacket: orange	 + red/ - white Jacket: white	 + black/ - red Jacket: green
Pt13Rh-Pt / R RCA: E-Cu/A-Cu	 + orange/ - white Jacket: orange	 + red/ - white Jacket: white	 + black/ - red Jacket: green
Pt30Rh-Pt6Rh / B BC: S-Cu/E-Cu	 + grey/ - white Jacket: grey		 + grey/ - red Jacket: grey
NiCrosil-Nisil / N NC: Cu-CuNi	 + pink/ - white Jacket: pink		
Cu-CuNi / U		 + red/ - brown Jacket: brown	
Cu-CuNi / T	 + brown/ - white Jacket: brown		
NiCr-CuNi / E	 + purple/ - white Jacket: purple	 + red/ - purple Jacket: purple	 + purple/ - red Jacket: purple

## Type label of standard versions

Each sensor has a type label attached to it. It is a moisture and wear proof industrial grade sticker, with black text on white label. This label has printed information as presented below.

Image below: Example of a standard sensor type label.



Manufacturer contact information.  
For some sensor types, this part  
may also be printed on a separate  
label for practical reasons.

Trade name  
Type code  
Product number  
Serial number with production date  
CE-mark (RoHS) | Serial number  
as QR code

## Serial number information

Serial number S/N is always printed on type label in the following form: yymmdd-xxxxxxx-x:

- yymmdd production date, e.g. “210131” = 31.1.2021
- -xxxxxxx production order, e.g. “1234567”
- -x sequential ID number within this production order, e.g. “1”

## EU Declaration of Conformity

The EU Declaration of Conformity, declaring products' conformance to the European Directives, is delivered with products or sent on request

## Manufacturer contact information

### Manufacturer HQ main office:

**Lapp Automaatio Oy**  
Street address Martinkyläntie 52  
Postal address FI-01720 Vantaa, Finland

### Production site and logistics:

**Lapp Automaatio Oy**  
Street address Varastokatu 10  
Postal address FI-05800 Hyvinkää, Finland

Phone (sales) +358 20 764 6410

Email [epicsensors.fi.lav@lapp.com](mailto:epicsensors.fi.lav@lapp.com)  
Https [www.epicsensors.com](http://www.epicsensors.com)

## Document history

Version / date	Author(s)	Description
20230707	LAPP/VeTe	Additional info for sensor cable installation.
20220822	LAPP/JuPi	Telephone number update
20220815	LAPP/JuPi	Material name text corrections
20220401	LAPP/JuPi	Original version

Although every reasonable effort is made to ensure the accuracy of the content of the operating instructions, Lapp Automaatio Oy is not responsible for the way the publications are used or for possible misinterpretations by end users. The user must ensure that she or he has the latest edition of this publication.

We reserve the right to make changes without prior notice. © Lapp Automaatio Oy