

EPIC® SENSORS

TEMPERATURE SENSOR FOR AUTOCLAVES, WITH CABLE
TYPE W-63, 2XW-63
DATA SHEET 26

INSTALLATION INSTRUCTIONS AND USER MANUAL

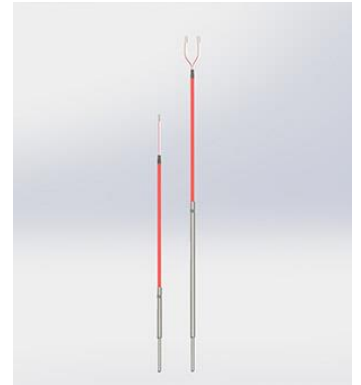

Table of contents

Product description and intended use.....	2
Temperatures, measuring.....	3
Temperatures, ambient.....	3
Code key.....	3
Technical data.....	4
Materials.....	4
Dimensional drawing.....	4
Installation instructions.....	5
Tightening torques.....	5
Pt100; connection wiring.....	6
Pt100; measuring current.....	6
Type label of standard versions.....	7
Serial number information.....	7
EU Declaration of Conformity.....	8
Manufacturer contact information.....	8
Document history.....	8

Product description and intended use

Sensor types W-63 (resistance, RTD) and 2xW-63 (2xresistance, 2xRTD) are temperature sensors with cable, specially constructed for applications in autoclaves.

Sensors are intended for various industrial measuring applications in autoclaves, sterilization devices, steam chambers, and in manufacturing industry. Sensors are meant to be immersed to process to be measured. The construction and materials are especially suitable for these use cases.

Sensors with cable are used in applications, where wiring connection point must be further away from the measuring point, or where there is no room for traditional sensor connection head. Another reason for choosing the cable structure is possibility to easily move the sensor from measuring point to another.

Measuring elements are RTD elements, standard versions are 4-wire Pt100 (for W-63), or 2x 3-wire Pt100 (for 2xW-63).

Sensor element protection tube material can be chosen, and element / cable length can be produced according to customer needs. Standard protection tube is AISI 316 / 316L with surface roughness $R_a = 0,6 \mu\text{m}$. Sensors are available with special cable with free wire ends, or with connector, according to customer order. Standard cable type is EMI shielded and has a medical grade silicone sheath.

Please note, that protection tube and cable diameter dimensions must have a specific match with each other, to provide tightness needed. Thus, all combinations are not possible.

Both standard and tailored versions are produced on request.

EPIC® SENSORS temperature sensors are measuring devices intended for professional use. They should be mounted by professionally capable installer who understands the installations surroundings. The worker should understand mechanical and electrical needs and safety instructions of the object installation. Suitable safety gear for each installation task must be used.

Temperatures, measuring

Allowed measuring temperature range for sensor tip is:

- -60...+180 °C With Pt100, for standard sensor element and cable materials.

Temperatures, ambient

Allowed maximum ambient temperature for wires or cable, for the standard cable type, is:

- Max. +180 °C FDS = FEP wire insulation/braid shield/silicone jacket.

Allowed maximum ambient temperature for standard shrink tube at cable connection end is:

- Max. +125 °C Irradiated Modified Polyolefin

Make sure the process temperature is not too much for the cable or shrink tube.

Code key

Example code: W — 63 — 100 — 5000 / FDS — 4 — A — X

W	= Pt100 resistance thermometer
2xW	= 2 x Pt100 resistance thermometer
63	= autoclave sensor (constant in code)
100	= length of sensor element, L [mm]
5000	= cable length, CL [mm]
FDS	= cable material (for more information, look technical data on first page of the datasheet)
4,3	= Pt100 wire count
A,B	= Pt100 accuracy class, (class A as standard delivery)
X	= additional details on the text line

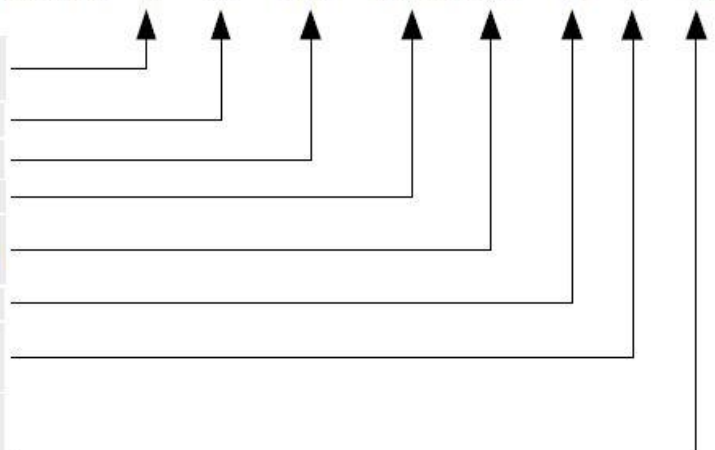

Technical data

Materials	AISI316/AISI 316L, maximum temperature +180 °C,
Surface roughness	Ra = 0,6 µm
Cable material	FDS = FEP wire insulation/braid shield/silicone jacket, max. +180 °C (medical grade silicone)
Tolerances Pt 100 (IEC 60751)	A tolerance $\pm 0.15 + 0.002 \times t$, operating temperature -100...+450 °C B tolerance $\pm 0.3 + 0.005 \times t$, operating temperature -196...+600 °C B 1/3 DIN, tolerance $\pm 1/3 \times (0.3 + 0.005 \times t)$, operating temperature -196...+600 °C B 1/10 DIN, tolerance $\pm 1/10 \times (0.3 + 0.005 \times t)$, operating temperature -196...+600 °C
Temperature range	-60...+180 °C
Quality certificate	ISO 9001:2015 and ISO 14001:2015 issued by DNV
IP rating	IP65, higher IP rating on request

Materials

These are the standard materials of components for the sensor types W-63, 2xW-63.

- Cable/wires please see *Technical data*
- Heat shrink tube Irradiated Modified Polyolefin (max. +125 °C)
- Sensor element AISI 316 or AISI 316L.

Other materials can be used on request.

Dimensional drawing

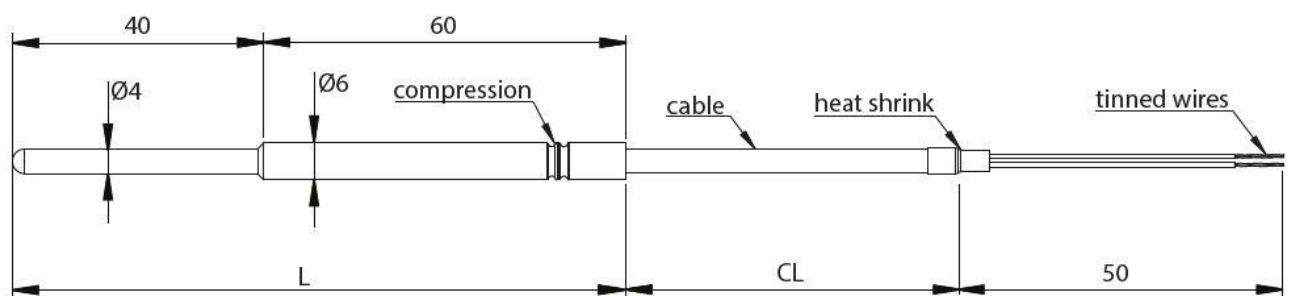

Installation instructions

Before any installation, make sure the target process/machinery and site are safe to work!

Make sure the cable type matches the temperature and chemical requirements of the site.

Installation phases:

- Never bend the measuring element.
- Insert the measuring element into atmosphere/medium to be measured.
- Mount the sensor securely with application-specific mounting accessories.
- Make sure there is no excess bending force or pulling loading the cable.
- Mount extra strain relief for cable, if necessary.

Tightening torques

Use only tightening torques allowed in applicable standards of each thread size and material.

Pt100; connection wiring

Image below: These are the connection colors of Pt100 resistor connections, according to standard EN 60751.

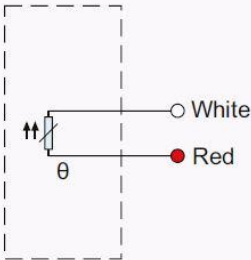
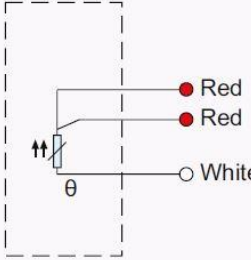
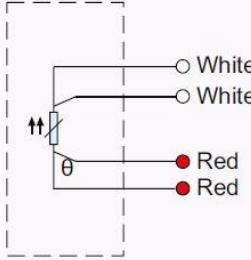
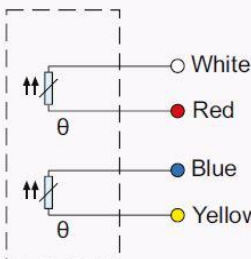
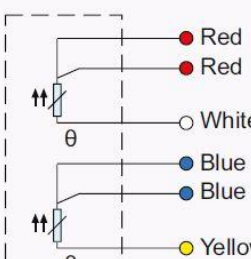
	2-wire	3-wire	4-wire
Pt100			
2 x Pt100			

Other connections on request.

Pt100; measuring current

The highest allowed measuring current for Pt100 measuring resistors depends on resistor type and brand.

Normally the recommended maximum values are:

- Pt100 1 mA
- Pt500 0,5 mA
- Pt1000 0,3 mA.

Do not use higher measuring current. It will lead to false measurement values and might even destroy the resistor.

Type label of standard versions

Each sensor has a type label attached to it. It is a moisture and wear proof industrial grade sticker, with black text on white label. This label has printed information as presented below.

Image below: Example of a non-Ex sensor type label.



Manufacturer contact information.
For some sensor types, this may also be printed on a separate label for practical reasons.

Trade name
Type code
Product number
Serial number with production date
CE-mark (RoHS) | Serial number as QR code

Serial number information

Serial number S/N is always printed on type label in the following form: yymmdd-xxxxxx-x:

- yymmdd production date, e.g. "210131" = 31.1.2021
- -xxxxxx production order, e.g. "1234567"
- -x sequential ID number within this production order, e.g. "1"

EU Declaration of Conformity

The EU Declaration of Conformity, declaring products' conformance to the European Directives, is delivered with products or sent on request

Manufacturer contact information

Manufacturer HQ main office:

Lapp Automaatio Oy
Street address Martinkyläntie 52
Postal address FI-01720 Vantaa, Finland

Production site and logistics:

Lapp Automaatio Oy
Street address Varastokatu 10
Postal address FI-05800 Hyvinkää, Finland

Phone (sales) +358 20 764 6410

Email epicsensors.fi.lav@lapp.com
Https www.epicsensors.com

Document history

Version / date	Author(s)	Description
20230707	LAPP/VeTe	Additional info for sensor cable installation.
20220822	LAPP/JuPi	Telephone number update
20220401	LAPP/JuPi	Original version

Although every reasonable effort is made to ensure the accuracy of the content of the operating instructions, Lapp Automaatio Oy is not responsible for the way the publications are used or for possible misinterpretations by end users. The user must ensure that she or he has the latest edition of this publication.

We reserve the right to make changes without prior notice. © Lapp Automaatio Oy