

Engineering Guide

Table of Content

Section 1	Cable chain introduction	15
	Elements of a cable chain	16
	Constructional material properties	19
	Environmental and chemical conditions	21
	Possible system configurations	22
Section 2	8 steps of cable chain engineering	25
Section 3	Cable chain accessories	33
	Self-supporting diagram	39
	System configurations	40
	Cable assembly guidelines	50

Cable chain introduction

A **cable chain** is a mechanical system designed to protect, carry and guide cables (power, control, data or fiber optics) and hoses (hydraulic or pneumatic) in dynamic motion applications - to transfer power and signal between two points in relative movement to each other (translation, rotation or combined movements). That is why cable chains are also considered an energy supply system for equipment with motion sub-systems.



cable chain

also referred to as



“drag chain”

“cable track”

“cable carrier”

“energy chain”

Advantages of cable chains

Competitive advantages of the cable chains as compared to the traditional systems of conductor bars and festoon systems are:

- The ability to carry different kinds of utilities (power, signal, data cables, hydraulic and industrial hoses)
- Compatibility of their use in harsh environments (presence of dust, humidity, aggressive chemical and atmospheric components, etc.)
- High speed and acceleration
- Shorter installation times (no motors or drives needed like in reels of festoons)
- Less and easier maintenance
- Much lower length of the utilities with equal travel distance of the mobile point

Main functions of a cable chain

- Allows the electrical and/or fluidic connection between two moving points, relative to each other in an easy and economical way
- Carries the cables and the hoses so that their motion will be controlled and determined
- Protects the cables and hoses mechanically and separates these from the effects for harsh environments
- Supports the cables and hoses which are installed inside the chain

Section 1 Introduction

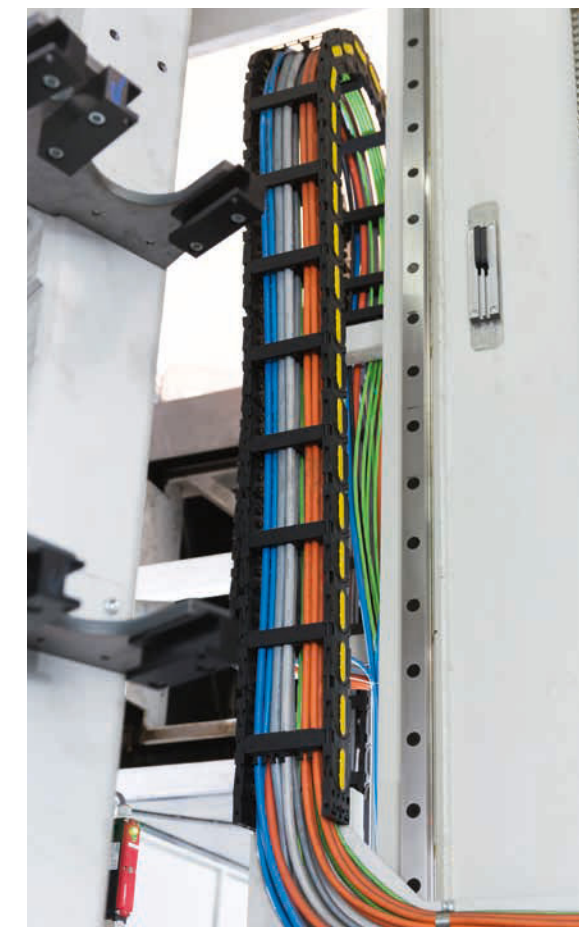
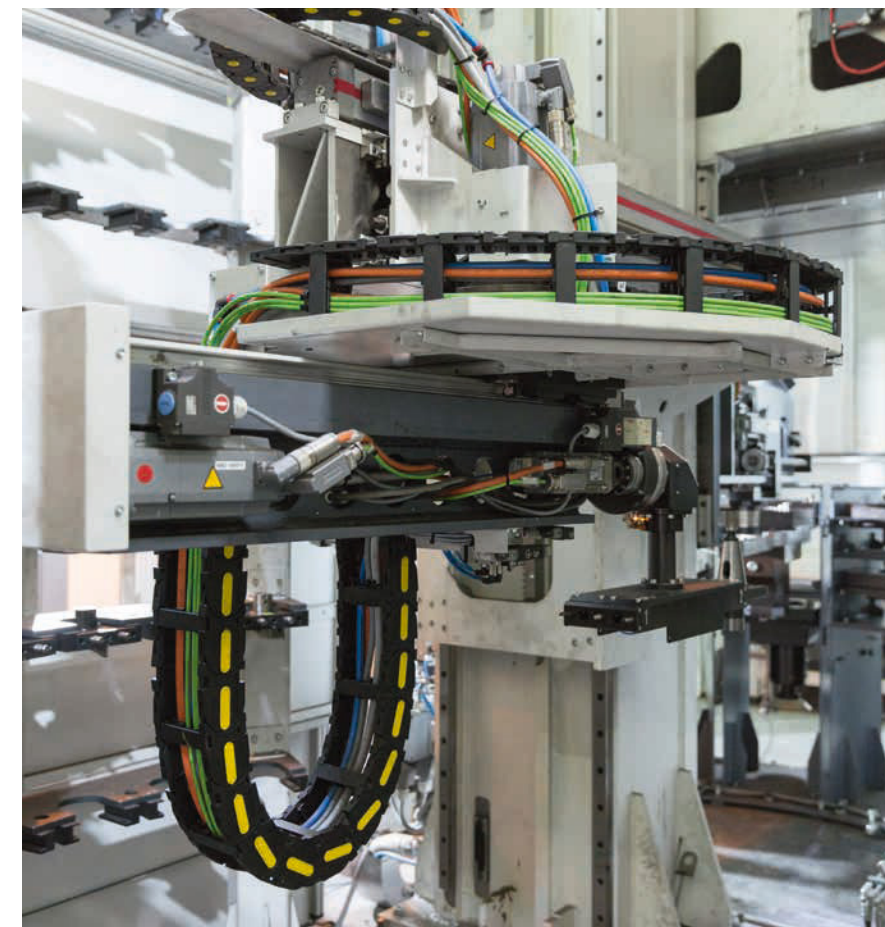

Elements of a cable chain system

A cable chain is an assembly of interconnected chain links terminated by end brackets on both sides. A wide range of accessories such as support rollers, guiding channels, etc. extends the possibilities of cable chain use.

One chain link consists of the following elements:

- Sideband composed of links
- Frames
- Separators
- Protective covers
- Pins

End brackets can be equipped by different types of cable fixing systems (nylon tie wrap clamps, steel cable clamps).

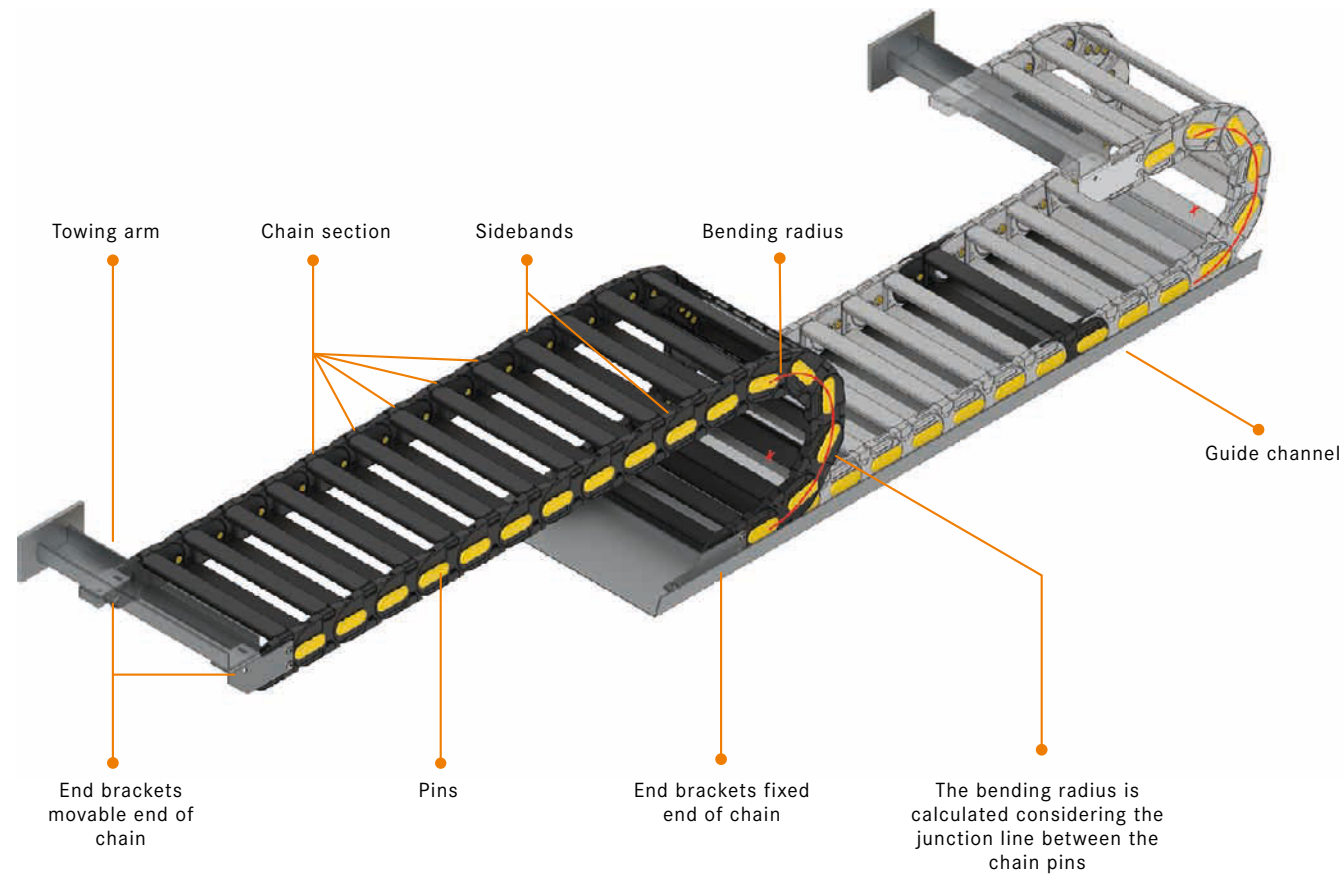

Frames

Different frame options are available depending on customers' application requirements.

For further details please see section "Frame variants" on page 36.

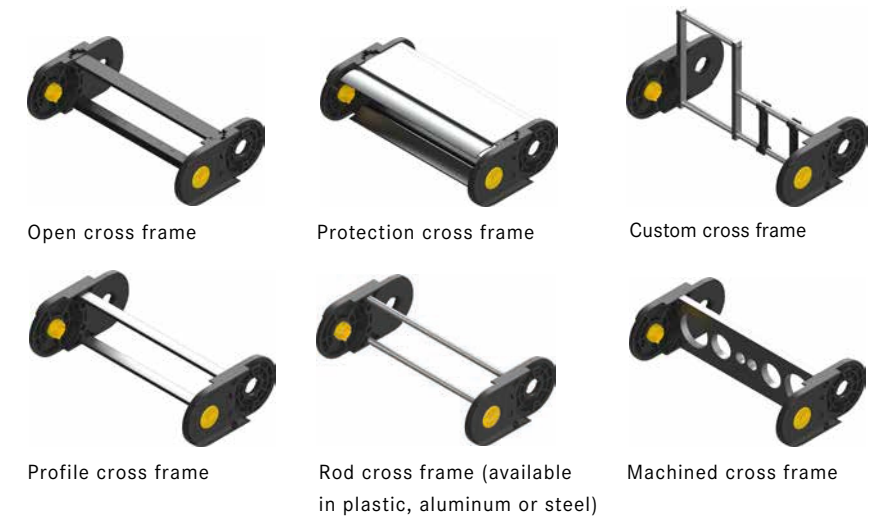

Separators

Cables and hoses need to be separated from each other in many cases. A wide range of cable chain separators is available for each type of chain, which allows infinite combinations of use to fit any requirement positions.

For further details and info please see section "Separation options" on page 38.

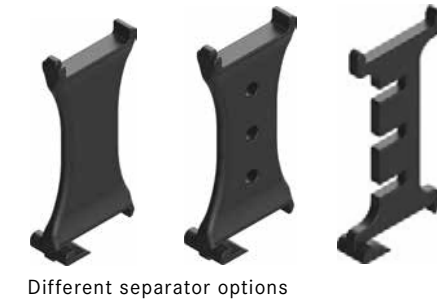

INFOBOX
As a general rule, the separators are mounted every second pitch. Different mounting frequencies may be required.

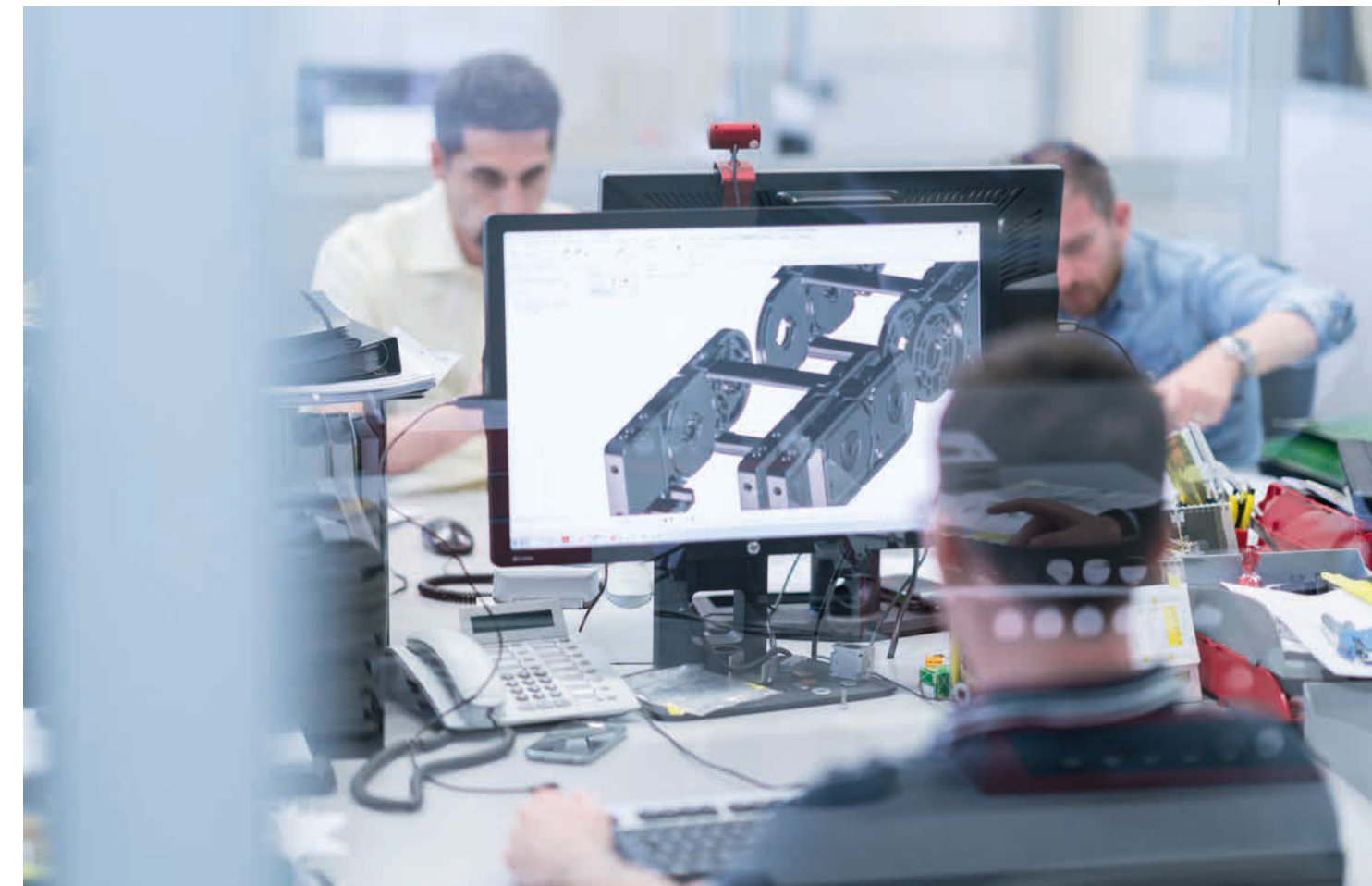

Protective covers

Cable chains are often located in very harsh environments, where a standard open-frame design is not enough. Nylon,

aluminum, galvanized or stainless steel covers are available for additional protection.



For further details and info please see section "Frame variants" on page 36.

Pins

Typical yellow pins connect chain links in most cable chain designs. A combination of black nylon chain and yellow pins are carefully selected to clearly visualise the possible danger of moveable devices. Different

types of pins can be used as a sliding element in cable chains working on side.

i Pin colours can be customised according to customers' specifications.



End brackets

The end bracket connects the cable chain system to the machine. It can be delivered in many different configurations and materials.



i A single kit code includes hardware for both end terminations.

Different end bracket type examples
For further details see section "End brackets" on page 33.

Dimensional cable chain parameters

The main geometrical features of a self-supporting cable chain are:

- LS** - Travel distance (stroke length)
- R** - Bending radius
- P** - Chain link pitch (distance between two hinge points on a side link)
- H** - Minimum upper installation height of the mobile point end bracket
- Pr** - Pre-set (also called "pretension")
- Ox, Oy, Oz** - Overall system dimensions
- LSA** - Distance of the feeding point from the extended end of the stroke
- A** - External chain link width
- B** - External chain link height
- C** - Inner chain link width
- D** - Inner chain link height
- N** - Position at reverse parking

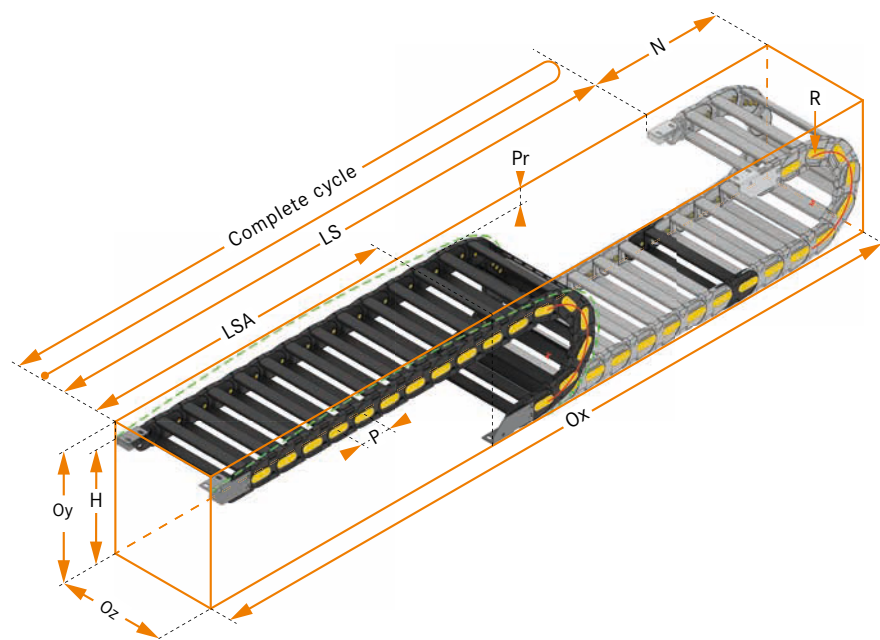

Constructional material properties

Used materials

The cable chains are distinguished by the materials used for the chain links and the materials used for the cross frame. We therefore divide the chains into:

Nylon cable chains

- Both cable chain links and the cross frames are made of a compound based on polyamide PA6 (BRYLON 6) for self-supporting, sliding applications or applications with circular movement
- For use in standard applications in most environments
- Open or fully closed design available

Steel cable chains

- Chain links are made of steel (galvanised steel or stainless steel - AISI304 or AISI316) for standard self-supporting, sliding applications or applications with circular movement
- Ideal for an environment in which nylon does not resist (e.g. extremely low or high temperatures, hot chips, etc.)
- Open or fully closed design available

Hybrid cable chains

- Chain links and cross frames are made of combined materials (e.g. nylon sidebands with aluminium frames or aluminium covers) for special requirements
- Combination of nylon, aluminium or steel parts help to withstand critical environments and to increase chain lifetime while maintaining optimal cost
- Open or fully closed design available

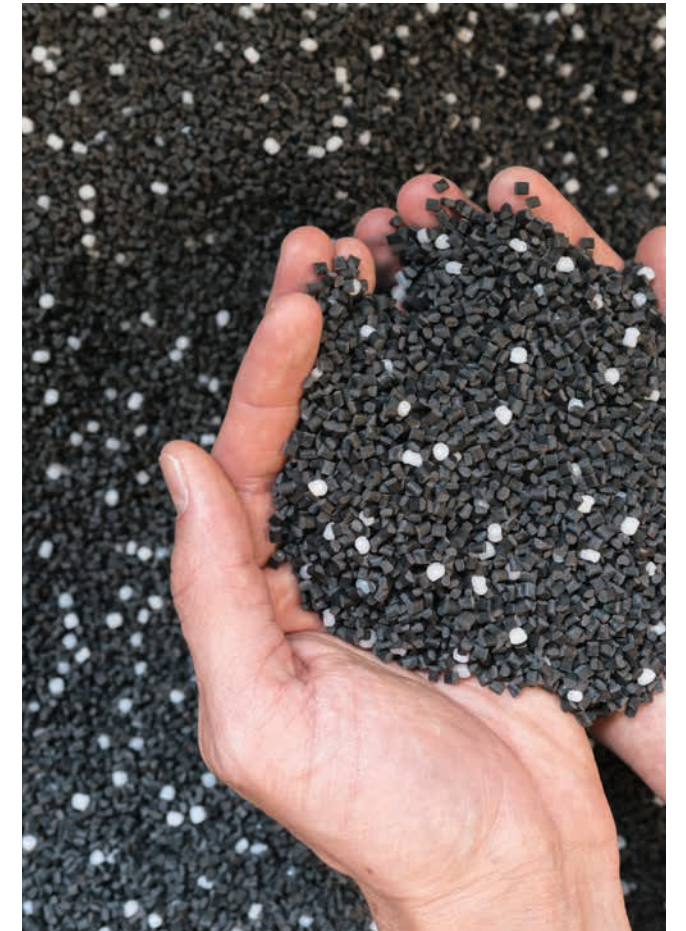

All materials used to manufacture cable chains are environmentally friendly (RoHS and WEEE)

Resistance and behaviour of nylon chains

Nylon cable chains are developed with a special polyamide reinforced with glass fibre, BRYLON 6. The high resistance to tension, the low friction coefficient together with the general characteristics of the most evolved compound thermoplastics allow the cable chains to be used in most environments and temperatures. The main characteristics of BRYLON 6 are:



Operational Temperature

- Nylon cable chains can be used in application with a temperature range between $-25\text{ }^{\circ}\text{C}$ and $+125\text{ }^{\circ}\text{C}$

- In case of application with "continuous" temperature lower than $-15\text{ }^{\circ}\text{C}$ or higher than $+95\text{ }^{\circ}\text{C}$, the mechanical values could be reduced. We are able to offer solutions using special compounds here.



For application ranging lower than $-25\text{ }^{\circ}\text{C}$ or higher than $+125\text{ }^{\circ}\text{C}$, please contact our technical office.



Self-Extinguishing

BRYLON 6 has the certificate UL-94HB. Polyamide V0 or V2 can be used on request.



Chemical Resistance

BRYLON 6 is generally resistant to oils, grease, petrol, ammonia and water (sea water). Problems could arise with the presence of acids.



UV Rays

BRYLON 6 is resistant to UV rays and it is therefore suitable for outdoor applications.



Explosion Proof

Drag chains suitable in high-risk explosion environments can be supplied made of the special material BRYLON AD. These chains comply with ATEX Directive 94/9/CE. For further information, please contact our engineering experts.



Clean room-proof

The standard version of the cable chain 305A009 has been tested and proved to be Class 1. For further information, please contact our engineering experts.



Colouring

Our drag chains come with a standard Colouring of black links and the yellow pins. On request, drag chains and/or pins can be produced in customised colors.

Resistance and behaviour of steel chains



Operational Temperature

- Steel cable chains can be used for temperatures up to 200°C because in case of higher temperature the surface treatment (zinc-plated galvanisation or painting) are damaged by heat
- Stainless steel lowercase cable chains can be used for temperatures up to 400°C



Self-Extinguishing

Not applicable



UV Rays

Steel and stainless steel are resistant to UV rays and they are therefore suitable for outdoor applications.



Chemical Resistance

- Zinc-plated steel is generally resistant in “normal” atmospheric environments. It is absolutely not suitable for marine or food environments. Moreover, problems could arise with the presence of acids, especially in presence of sulphur, chlorine and ammonia
- Stainless steel is suitable for harsh, food and nuclear environments. It is also suitable (in grade AISI316L) for use of sea water. If in water and in contact with other metallic parts, galvanic corrosion can occur. The corrosion resistance of stainless steel can be improved with surface treatments such as electro-polishing



Colouring

There are no limitations for steel chain colouring. However the relative movement between the links can damage the painting, so painting steel chains is not recommended.



Explosion Proof

Stainless steel cable chains are suitable in explosion-proof environments. These chains comply with ATEX Directive 94/9/CE. For further information, please contact our engineering experts.



Clean room-proof

Steel chains are not suitable for the use in clean rooms. Not applicable.



Environmental and chemical conditions

The table shows the resistance to chemical agents of BRYLON 6 and steel.



























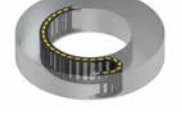

Chemical agents	Concentration %	BRYLON 6		STEEL
		Amorphous	Crystal	
Methyl acetate	100	+++++ 3	+++++ 2	+++++
Acetone	100	+++++ 4	+++++	+++++
Acetic acid (aqueous solution)	40	++	++	++
Acetic acid (aqueous solution)	10	++	++	++
Acetic acid		++	++	
Citric acid	10	+++ 15	++++	+++
Hydrochloric acid (aqueous solution)	36	+	+	+
Hydrochloric acid (aqueous solution)	10	++	++	+
Hydrochloric acid (aqueous solution)	2	++	+++	+
Chromic acid (aqueous solution)	10	++	++	++
Chromic acid (aqueous solution)	1	++++	++++	++
Hydrofluoric acid	40	++	++	+
Formic acid (aqueous solution)	85 S	+		+++
Formic acid (aqueous solution)	40 S	++	++	+++
Phosphoric acid (aqueous solution)	10	++	++	+
Oleic acid	100	+++++ 3	+++++ 3	+++++
Sulphuric acid	98	+	+	+
Sulphuric acid (aqueous solution)	40	++	++	+
Sulphuric acid (aqueous solution)	10	++	++	+
Sulphuric acid (aqueous solution)	2	++	+++	+
Tartaric acid (aqueous solution)		++++	++++	++++
Water		+++++ 10	+++++ 9	++++
Chlorine water		++++	++++	+++
Ethyl alcohol	96	++++ 17	+++++ 3	+++++
Ammonia	10	+++++ 1	+++++	++
Petrol	100	+++++ 1	+++++	+++++
Bitumen		++++	++++	+++++
Potassium carbonate	100	+++++	+++++	++
Sodium carbonate	10	+++++ 10	+++++ 3	++
Ammonium chloride (aqueous solution)	10	+++++	+++++	++
Calcium chloride (aqueous solution)	20	+	+	++
Calcium chloride (aqueous solution)	10	+++++	+++++	++
Sodium chloride	10	+++++	+++++	++
Formaldehyde (aqueous solution)	30	++++	++++	+++
Fat		+++++	+++++	+++++
Milk		+++++	+++++	+++++
Mercury		+++++	+++++	+++++
Oils		+++++	+++++	+++++
Oil		+++++	+++++	+++++
Paraffin oil		+++++	+++++	+++++
Silicon oil		+++++	+++++	+++++
Diesel oil		+++++	+++++	+++++
Mineral oil		+++++	+++++	+++++
Ozone		++	++	++
Oil		+++++	+++++	+++++
Potassium hydroxide (aqueous solution)	10	+++++ 9	+++++ 3	+
Sodium hydroxide (aqueous solution)	50	++++	++++	+
Sodium hydroxide (aqueous solution)	10	+++++ 5	+++++	+
Sodium hydroxide (aqueous solution)	5	+++++ 9	+++++	+
Aluminium sulphate	10	+++++	+++++	++
Soap (aqueous solution)		+++++	+++++	+++++
Tincture of iodine		++	++	+++
Trichloroethylene		++++ 5	++++ 4	+++++
Vaseline		+++++	+++++	+++++

Resistance classification indicator

- +++++ Very good resistance
- ++++ Good resistance
- +++ Limited resistance
- ++ Poor resistance
- + Soluble
- Amorphous** Polymer in amorphous state
- Crystal** Polymer in crystalline state

The number beside the resistance classification indicator (+++++, +++, etc.) shows the percentage of weight increase due to absorption.

Possible system configurations

	Self-supporting	Sliding	Side mounted	Vertical
Single chain configuration	<p>Upper moving</p>  <p>Lower moving</p> 	<p>Sliding</p> 	<p>Cable chain side mounted</p> 	<p>Vertical with lower radius</p>  <p>Vertical with curve above</p>  <p>Zig zag</p> 
Multiple chains configuration	<p>Side by side</p>  <p>Ring configuration</p>  <p>Nested cable chains configuration</p> 	<p>Two sliding cable chains in ring configuration</p> 	<p>Two cable chains in ring configuration side mounted</p> 	<p>Vertical two cable chains in ring configuration</p>  <p>Vertical nested cable chains</p>  <p>Vertical side by side</p> 
Multi-axis motion	<p>Upper moving</p> 		<p>Cable chain side mounted</p> 	<p>Radius below</p>  <p>Radius above</p> 
Rotations single chain	<p>Robot series</p> 		<p>Single cable chain side mounted</p>  <p>Single cable chain side mounted - rotating floor</p> 	<p>Single cable chain - horizontal axis</p>  <p>Robot nested</p> 
Rotations multiple chain	<p>Multiple Robot series cable chains</p> 		<p>Multiple cable chains side mounted</p>  <p>Multilayer up to $\pm 330^\circ$ /layer</p> 	<p>Multiple cable chains horizontal axis</p>  <p>Multilayer up to $\pm 330^\circ$ /layer</p> 



Section 2 Cable chain engineering

Cable chain engineering in 8 easy steps

- 1 Input data to determine the type of cable chain**
Collect all necessary application requirements: cable and hose specifications (weight, outer diameter, jacket material, bend radius), chain travel distance, available space, bracket fixing configuration, etc.
- 2 Cable chain layout design**
Determine required inner cable chain space while applying all basic rules and check with available application space
- 3 Selection of cable chain type**
Select a cable chain which fits to requirements using a product selection table
- 4 Bend radius**
Calculate suitable bending radius in accordance with parameters of all flexible cables and hoses
- 5 Cable chain length calculation**
Calculate appropriate cable chain length in accordance with given travel distance
- 6 Self-supporting capacity calculation**
Determine self-supporting capacity with respect to an additional load
- 7 Double-check of selected cable chain type**
Choose cable chain that fits to determined requirements
- 8 Selection of accessories**
Specify additional components such as end brackets, separators and channels in accordance with selected chain type

► Please find detailed information on each point above in the following sections.

1 Input data to determine the type of cable chain

The choice of cable chain should not only be based on a mathematical calculation of certain factors but should consider and analyse carefully all the available data. The following information will provide basic help in making the right decision.

The first step in cable chain selection is the definition of the internal chain link dimensions. Therefore, key technical parameters must be defined:

Utilities

Cables

- Overall diameter ODc (mm)*
- Weight (Kg/km)*
- Minimum dynamic bending radius MBR (mm)*
- Type → power, signal, data, optical
- Material → PVC, PUR, etc.

Hoses

- Overall diameter ODh (mm)*
- Empty weight (kg/m) and full weight (Kg/m)*
- Minimum dynamic bending radius MBR (mm)*
- Working pressure
- Linear expansion % under pressure
- Radial expansion % under pressure
- Type → industrial, hydraulic, pneumatic
- Media → air, water, mud, oil, etc.

Application parameters

- Type of movement (linear, rotation, combined)
- Travel distance LS
- Speed
- Acceleration
- Installation available room (Ox, Oy, Oz – mm)
(Possibility to use more than one chain)

Duty cycle and service factor

- Cycle time
- Working hours a day
- Working days a week
- Service factor %

Application environment

- Temperature
- Humidity %
- Outdoor vs. indoor
- Clean vs. dirty
- Presence of chemical agents

*Mandatory data (required spare space Sp% and distance Du of separation between different utilities if required)

INFOBOX

Cable chain is used for protection and guiding of flexible cables and hoses installed in a cable chain. For that reason chains must always be designed in accordance with cable/ hose features and not the other way round.

i Our long-term experience in cables enables us to support you with any kind of technical advice. Please contact our technical engineers.

2 Cable chain layout design

To ensure proper cable chain functions and to avoid any damage to the cables, please determine the right chain size according to following basic rules:

Legend

- Cable
- Hose

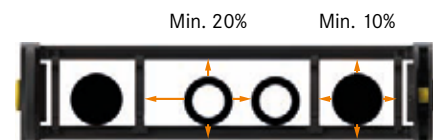

Fig. 1

1) For electric cables, a clearance of at least 10% between the cable and the outer frame must be guaranteed; for pneumatic lines the clearance should be 15%, while for hydraulic hoses the clearance should be at least 20% (Fig. 1)



Fig. 2

2) Avoid placing cables/hoses that have different outer sheaths together in one section so that friction can be eliminated (e.g. cables and hydraulic hoses) (Fig. 2)

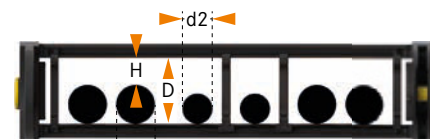

Fig. 3

3) If several cables/hoses are used, it is preferable to avoid them rubbing each other by placing them in an isolated space and using separators to separate them. If this is not possible, verify that the internal space does not allow cables/hoses to be twisted. $H < d2$ or, for any couples of utilities not separated each other, $\rightarrow d1 + d2 > D$ (Fig. 3)



Fig. 4

4) Place cables/hoses symmetrically according to their dimensions and weight, placing the largest and heaviest externally and the smaller and lighter ones internally (Fig. 4)

Multi-layer layout

In case of space limitations, one option can be to reduce the link width. Link height must be increased accordingly. Then utilities have to be placed on more layers.

i For multi-layer utility layouts, please contact our specialists.

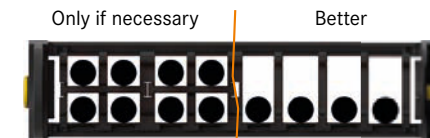
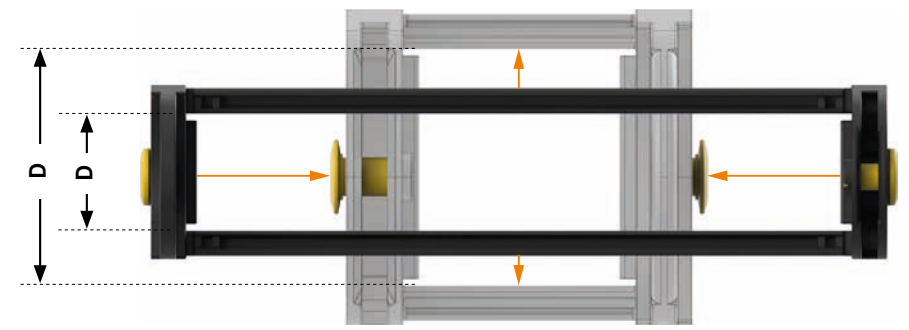

Fig. 5

5) If possible, all cables should be placed in one single layer. This will improve the operating life time of the system. Multi-layer separators are difficult to assemble, maintain and are more expensive (Fig. 5)



$D > 1.1 \text{ ODc (for cables) / } D > 1.2 \text{ ODh (for hoses)}$

3 Selection of cable chain type

Make the first selection of a cable chain from our product selection table (see page 52/53) in accordance with the required inner chain link dimension, taking into account material type (nylon vs. steel), speed, acceleration and other factors.

If the calculated cable chain width is too wide, please choose from the following options:

- Multiple chains in nested or ring configuration (see page 22/23)
- Layout with utilities on more layers inside the cross section of the cable chain (see step 2)

Nylon



Multiple Application Series



Heavy Duty



Sliding Applications

Steel



Multiple Application Series



Sliding Applications

Robot



Robot Series

4 Bend radius

In order to define the → **Bend Radius (BR)** of a cable chain, the list of all the cables and hoses needs to be considered: all bending radii of cables and hoses determine which chain BR has to be chosen → chain BR has to be equal or higher than highest cables/hoses **MBR (Maximum Bend Radius)**.

i Please check the technical data sheet of each input utility.

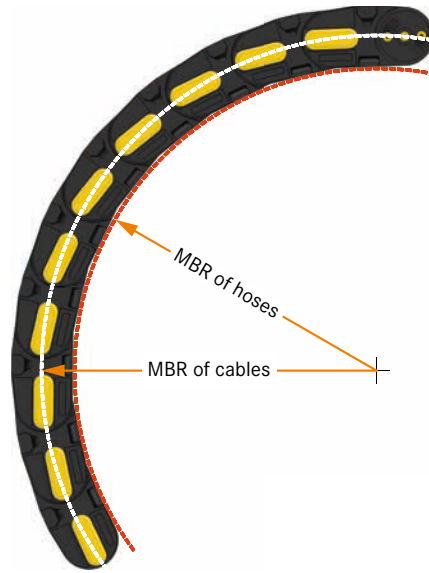

- Please consider that:
- The cable MBR is calculated in relation to the central axis
 - The hose MBR is calculated in relation to the inner bending



5 Cable chain length calculation

Considering the distance LSA between the feeding point and centre of travel distance LS, five different configurations are possible:

Feeding point position

LSA=LS/2 Centre feed

i Most common type of configuration

Feeding point position

LSA>LS/2 Overlength mobile point

0<LSA<LS/2 With offset

LSA=0 End feed

LSA<0 Overlength feeding point

INFOBOX

Since a cable chain is a sequence of links, the chain length must be a multiple of the pitch "P".

For the steel chain N-series only, the round up must be taking account of the odd number of chain links.

Legend

- LS** = Travel distance
- LSA** = Fixed point displacement in relation to the extended end of the stroke
- M** = Bent length of the chain
- R** = Chain's bending radius
- P** = Pitch
- N** = Parking space when the chain is completely retracted*
- H** = Mobile point installation height

* based on chain's minimum length needed to achieve the travel distance.

L, LSA → input data

M → value in catalogue table (**Fig. 1**). M is determined under point 4, bending radius definition

Difference between M & M1:

M → value of the bent chain's length in self-supporting configurations

M1 → value of the bent chain's length in sliding configurations

Chain bending radius "R"

Bent chain length "M", "M1"

$$L_{calc} = LS + M - LSA \text{ (when } LSA \leq LS/2 \text{)}$$

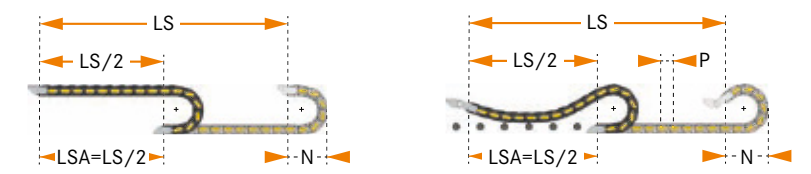

$$L_{calc} = M + LSA \text{ (when } LSA > LS/2 \text{)}$$

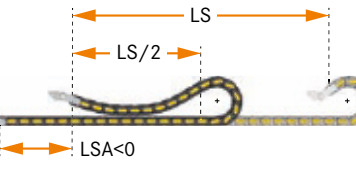
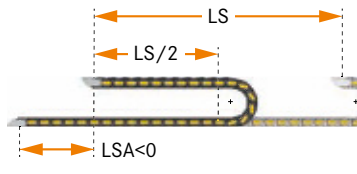
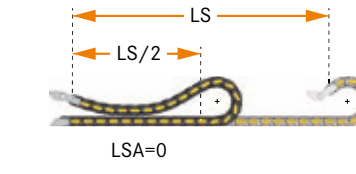
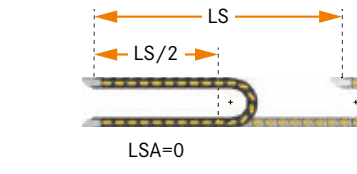
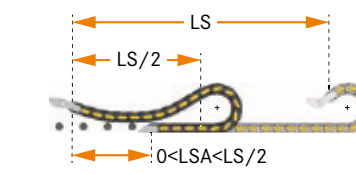
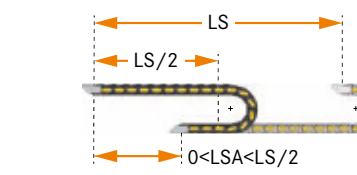
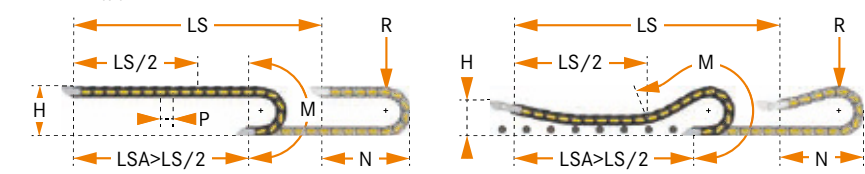

The table provides technical data for the SILVYN CHAIN 445 SERIES, including dimensions (A, B, C, D, E, F, G, H, I, J, K, L, M, N, O, P, Q, R, S, T, U, V, W, X, Y, Z), weight, and part numbers. It also includes a Self-Supporting Capacity Diagram and a note about applications with 'T' and weights not included.

Fig. 1

6 Self-supporting capacity calculation

Pre-set

The pre-set (Pr) is a fundamental feature in cable chains. This determines the self-supporting capacity which allows the cable chain to support not only its own weight, but also the weight of the cables/hoses placed inside. Empty cable chains there-

fore appear to be curved upwards slightly. Each chain has its own self-supporting diagram, which shows the maximum additional load (Kg/m) that the cable chain can support in relation to the unsupported length LS/2 (m). No support is needed

when the cable chain stays below the curve. Cable chains above the curve need to be supported or switched to stronger cable chain or a sliding configuration.

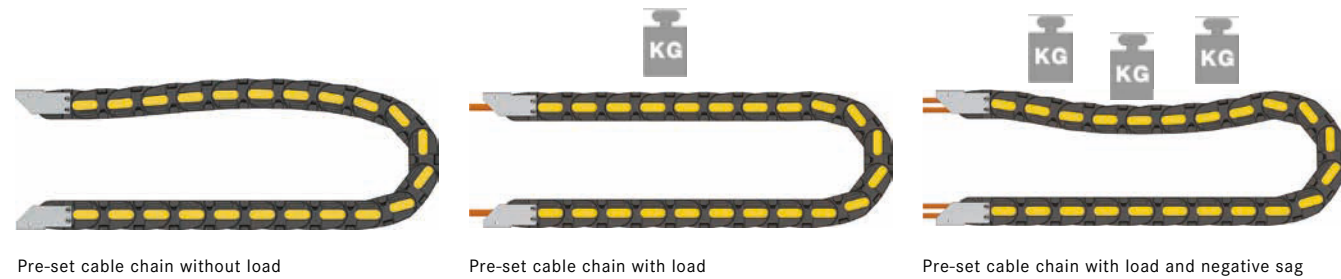

Self-supporting diagram

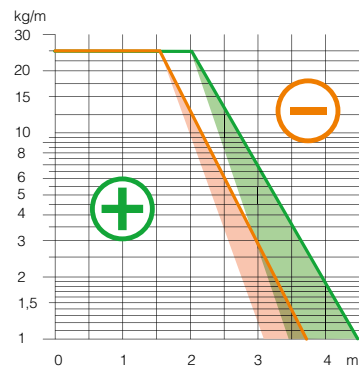
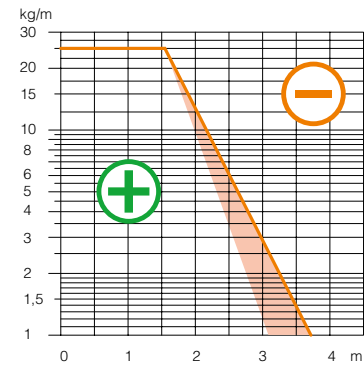

The curve in the self-supporting diagram (orange line) represents the free deviation length of the cable chain (self-supporting length SL) that nullifies the cable chain's pre-set with a certain additional load. The light orange area on the left side (the descending line) of the curve takes into account the fact that, for equal sidebands, a wider cable chain corresponds with a bigger weight and therefore a lower capacity to support the additional load of the utilities.

A cable chain can also be used outside its self-supporting area, accepting that the suspended portion of the chain works with a sag. Please also note that cable chains with a sag must be operated with lower speed and acceleration. In addition, the lifetime will be reduced.

INFOBOX

If the application parameters require that the intersection between the two lines falls above the diagram, the chain must be supported or sliding. Please refer to the specific section "self-support diagram and system configurations" on page 39.

i For the maximum value of the admissible sag of each series, please contact our technical office.

7 Double-check of selected cable chain type

If the calculated values apply to the properties of the selected cable chain, the selection process is finished. The cable chain dimensions can then be

determined: when selecting a chain, available space conditions must match dimensions C and D (Fig. 1). Please check that the overall dimension A is lower than the

available space Oz. (See illustration on page 18)



However if it is necessary to find another chain, the following options are available:

- Selection of a stronger/bigger cable chain type (go back to step 3)
- Cable chain in sliding configuration (go back to step 3)
- Steel cable chain (go back to step 3)
- Possibility to use support rollers (see page 41)

8 Selection of accessories

Necessary accessories need to be specified from relevant product pages, for example end brackets, separators, cable fixing clamps, guiding channels, etc.

Useful tips and recommendations for use of different kinds of cable chain accessories and system configurations in section 3 (from page 33 onwards).



Section 3
Specific product topics

Cable chain accessories

End brackets

Mounting positions

The mounting positions of the end brackets allow the cable chain to be fixed in the configurations described below. Unless otherwise specified, the chains are supplied with the end brackets mounted in Pos. 1.

i Any mounting needs not listed below? Please contact us.



Pos. 1, mounting both external radii



Pos. 2, mounting external radius & internal radius



Pos. 3, mounting both internal radii



Pos. 4, mounting front



Pos. 5, mounting turned inside



Pos. 6, mounting turned outside

Materials and shapes

End brackets can be delivered in different materials and shapes.



Bracket in "U" shape
Available for small chains in steel or nylon. The correct mounting position must be specified. It is fastened using slots that allow a mounting tolerance.



Bracket in "L" shape
Available in steel or nylon. The correct mounting position must be specified. It is fastened using slots that allow a mounting tolerance.



Bracket in "I" shape
Available in nylon.
The mounting position is automatically determined by the end bracket. It is fastened using holes that require low mounting tolerance.



Universal bracket
Available in nylon.
Different mounting possibilities in one piece.

Locked or pivoting

Depending on the shape or use of the end brackets they can be locked or pivoted.



Locked end bracket
Suggested for standard horizontal or vertical applications.



Pivoting end bracket
Used for sliding applications and rotations.

i Due to the dynamic behaviour in sliding applications it is mandatory for the end bracket to be pivoting in order to balance the downward and upward movement of the cable chain while keep following the linear movement of the towing arm.

Fixation devices

Cable clamps, cable combs and fixation profiles are fixation devices. They allow the utilities to be fixed at the end of the chain, which preserves them from unexpected breakage. A minimum distance of 15 x OD of the utility will be left between the last link that bends during the movement of the chain and the position of the fixation system.

Fixation profiles



Cable clamps



Cable combs



Integrated combs



Clip mounted on cross frame



Clip mounted on a profile

Depending on the type of chain, these combs can be found directly integrated into the end bracket (usually for small chains).

Can be mounted as a clip directly on the end bracket cross frame.

For larger cable chain sizes, these combs are mounted as an additional component on a special aluminium profile designed to ensure optimal strength.



Frames

Frame variants

Definition of terms

Customisation

Ability to meet the customer's dimensional requirements.

Stiffness

Capacity which has the cross frame to oppose to the elastic deformation caused by a force applied.

Cable harnessing

Is related to the utilities (cables/hoses) in the chain.

Cable protection

Ability to protect the utilities from external agents and to minimise their wear.

Legend



Nylon open cross frame version

Lightness: ****
 Cable harnessing: ***
 Stiffness: *
 Cable protection: **
 Customisation: **
 Price: *



Protection cross frame version

(available in plastic or aluminum)
 Lightness: ***
 Cable harnessing: **
 Stiffness: **
 Cable protection: ****
 Customisation: **
 Price: **



Aluminum profile cross frame version

Lightness: ***
 Cable harnessing: **
 Stiffness: ***
 Cable protection: **
 Customisation: ***
 Price: ***



Rod cross frame version

(available in plastic, aluminum or steel)
 Lightness: ***
 Cable harnessing: **
 Stiffness: ***
 Cable protection: **
 Customisation: ***
 Price: ***



Machined cross frame version

(available in plastic or aluminum)
 Lightness: *
 Cable harnessing: **
 Stiffness: ****
 Cable protection: ***
 Customisation: ***
 Price: ****



Custom cross frame version

Lightness: ***
 Cable harnessing: ***
 Stiffness: ***
 Cable protection: **
 Customisation: ****
 Price: ****

Frame opening options

Our portfolio contains modular frame opening options for different nylon cable chains:

- The **hinge open frame** stays fixed to the side band, facilitating and speeding up the harnessing operations.
- The **snap open frame** offers the advantage of easy and fast removal and allows the possibility to position the cables in a convenient way. This is mandatory when the cables are already equipped with connectors.



Hinge open outside bending radius



Hinge open inside bending radius



Snap open outside bending radius



Snap open inside bending radius



Universal hinge/snap opening



Bolted cross frames

This option allows maximum flexibility during wiring while maintaining a good stiffness of the chain.

This option also offers the possibility to open the chain. This operation requires more time but ensures greater stiffness of the chain.

Separation options

The wide range of separators available for each type of chain allows infinite combinations of use to fit any requirement. As a general rule the separators are mounted in every second chain link. Different mounting frequencies may be required.

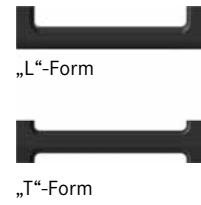
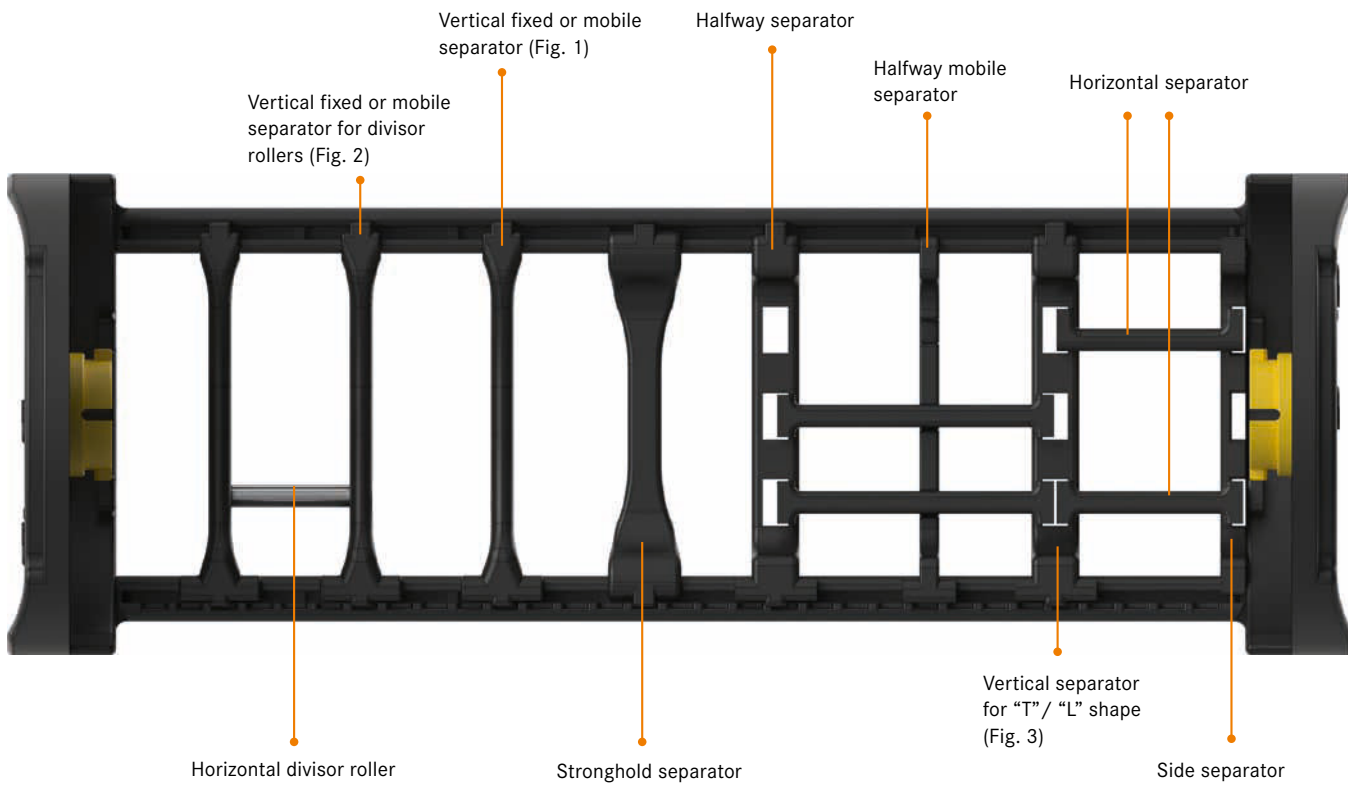

Side separator:
The vertical separator which prevents damage to the utilities caused by their contact and wearing against the chain sidebands or is used to keep horizontal separators in position.

Internal vertical separators:
All types of separators which are not side separators.

Other vertical separator types:



Vertical fixed or mobile separator (Fig. 1)

Horizontal separation options work with:



Vertical fixed or mobile separator for "T" and "L" shape (Fig. 2)
Vertical separator for "T" and "L" shape (Fig. 3)

i For separation systems available for specific chain types, please refer to the respective product pages.

Self-supporting diagram

There are two ways to work with the self-supporting diagram (Fig.1):

- Starting from the additional load (so from the cross section sizing), the maximum self-supporting length that the chain can reach can be checked
- Starting from the self-supporting length (so from the system configuration), the maximum additional load that the chain can support can be checked

The list of utilities that the system should drag is called the input data. To carry additional loads, often the only way is to use more than one chain, distributing it on more chains (nested, side by side or in a ring configuration). In accordance with this, the self-supporting diagram is used in the "B" option, mainly at the beginning of system dimensioning, when the decision needs to be made to use one or more chains.

After determining the chain number and distributing of utilities among them, use the diagram in the way "A" to define the configuration of the cable chain system. This just relates to self-supporting configurations with fixed point in centre position, $SSL = LS/2$.

The horizontal axis represents the maximum self-supporting length SSL of the configuration (often mistakenly defined as half of the travel distance $LS/2$).

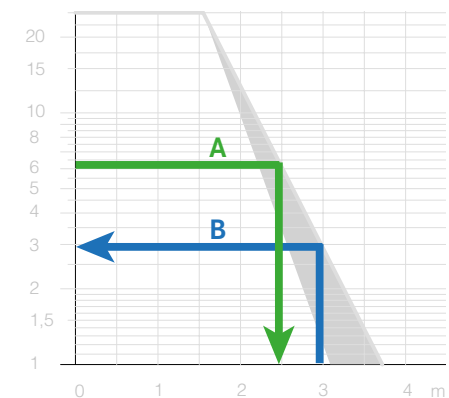

Fig. 1

Looking at the diagram (Fig.2), and working in the way "B", the green line level is fixed (because the additional load is determined). Viceversa, the vertical blue line moves to the right increasing the travel distance. When the maximum self-supporting length is exceeded, a configuration has to be chosen that supports the chain in a better way.

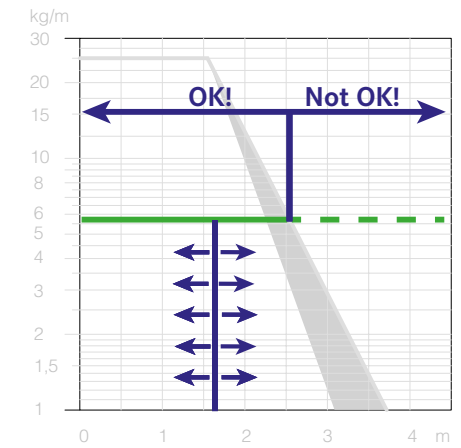

Fig. 2

Considering an application with fixed point in centre position:

- Self-supporting applications → $SSL = LS/2$
- Supported application with 1 support roller on the extended side of the stroke → $SSL = LS/3$ (single support roller should be positioned at a distance of $LS/3$ from the extended end of the stroke) (Fig. 3)
- Supported application with 2 support rollers on the extended side of the stroke → $SSL = LS/4$ (the two support rollers should be positioned at the centre and at $3/4$ of the travel distance) (Fig. 4)

*SSL = Self-supporting length

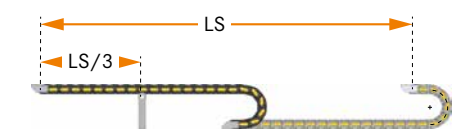

Fig. 3

Generally there are no limitations in the number of support rollers. However, if the stroke exceeds its capacity ($Max\ SSL < LS/4$) sliding configurations or other system accessories have to be used such as supporting hooks, side rails or trolleys.

INFOBOX
The self-supporting diagram is determined by testing the chain when it is new. But the self-supporting performance of the chain declines as wear and tear increases, so a used chain has less self-supporting capacity than a new one. This must be considered in the calculation of the system requirements.
If your application results are close to the limit values, please contact our technical office for additional evaluations.

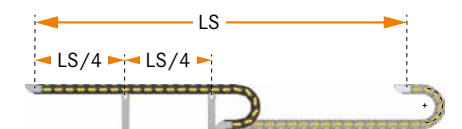
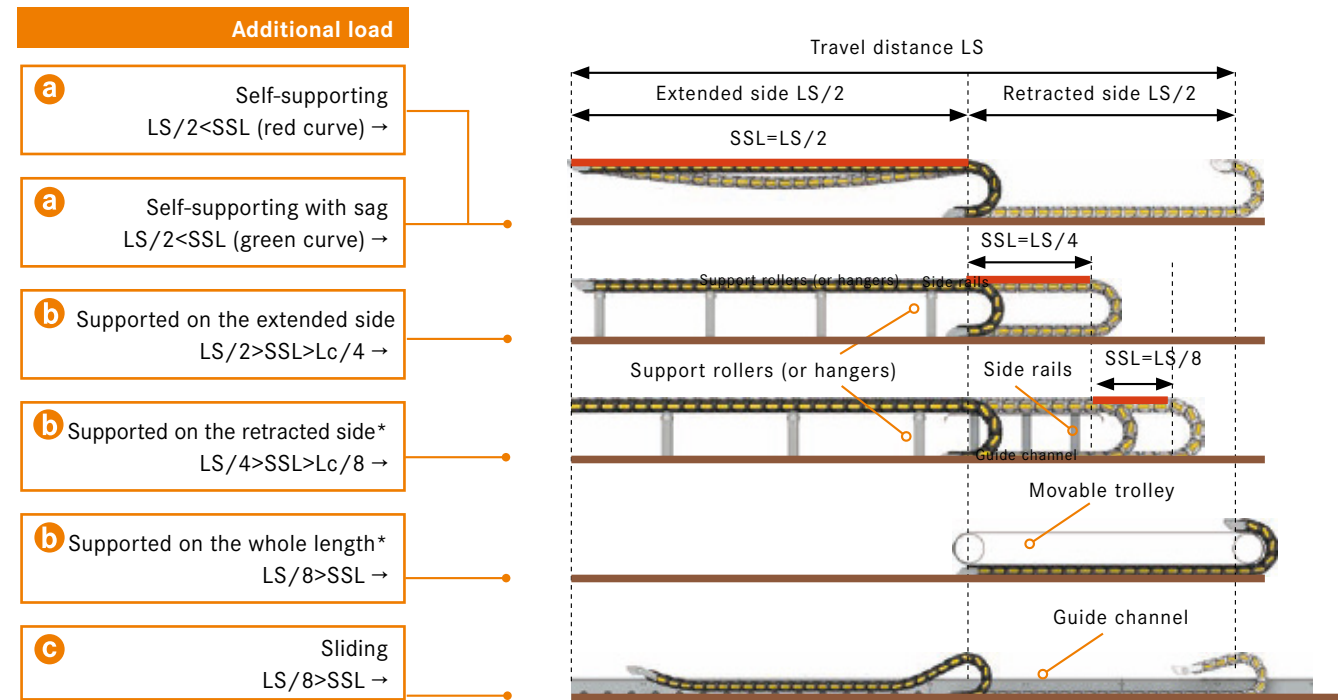

Fig. 4

System configurations

Depending on the ratio between the travel distance **LS** of the mobile point and the self-supporting length **SSL**, there are different possible configurations:



i The chain section that is not possible to support is highlighted in red. The combination of additional load and self-supporting length must remain lower than the self-supporting curve of the diagram.

*Among the three configuration options, the sliding configuration guarantees longer travel distances and is more cost effective since no side rails and trolleys are needed.

a Self-supporting configuration

In self-supporting configuration, the chains work with or without sags. The advantages are:

Self-supporting chains without sag

- Operate with higher speed and acceleration
- Stress chain and cables less, so the operational life is longer

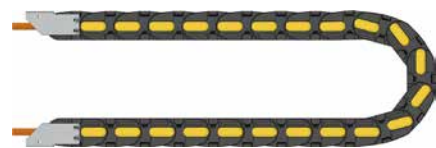

Self-supporting chains with sag

- Reach longer travel distances
- Sometimes the cheaper solution due to smaller cable chain sizes



All the self-supporting configurations

- Do not require a guiding channel but at least a ground channel on the retracted side (see page 41)
- Require a strain relief mounted on both ends (see page 50/51)
- Are manufactured with pre-set
- Must be connected at installation height **H** or higher (not lower)
- Have less wear than sliding configurations (no friction between chain when operating)
- Increasing pre-tension may increase the self-supporting length
- The end brackets need to carry the system's complete load (weight of chain & cables plus dynamic forces)

b Supported configurations

Support rollers

In case of supported cable chain configurations, different kinds of support rollers can be used. See dimensions of our standard rollers in the table below.

i Many different custom types can be created upon request.

Chain Type	X	Y	L
Nylon		A-23 \\	A+60
Steel	20	70	100
	30	70	100
	35	70	100
	40	70	100
	45	130	180

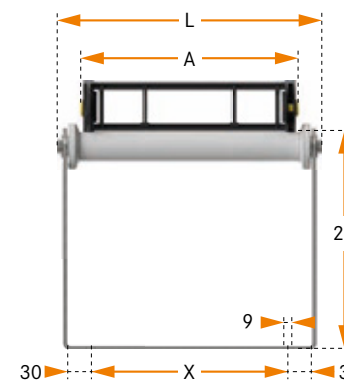

Support roller for nylon chains

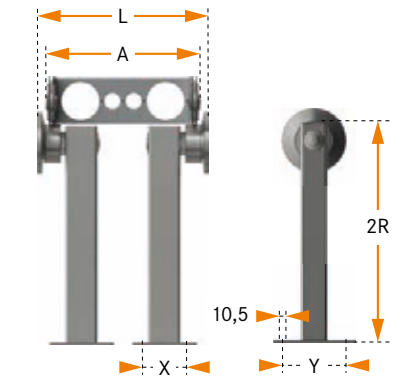

Support roller for steel chains

Guiding channels/ground channels

Chain Series	A5	H	S
200 - 250	A + 2mm	10	1.5
325	A + 2mm	25	1.5
335 - 445 - 660A - 770A - 306 - 307 - 660 - 770 - 20	A + 2mm	30	1.5
308 - H57 - 30	A + 2mm	40	1.5
475 - 309 - H80	A + 2mm	50	1.5
35	A + 2mm	50	3
40 - 42	A + 4mm	50	4
45	A + 4mm	70	4
H110	A + 4mm	80	1.5

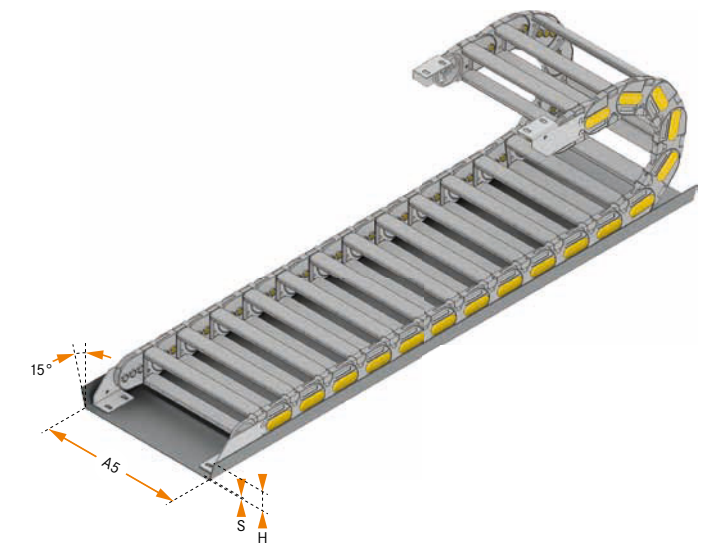

Ground channel

Legend

- W** → Distance between fixing holes
- Y** → Distance between fixing holes
- A** → External chain link width
- L** → Max. width of support roller

- A5** → Internal base width of channel
- H** → Max. height of channel
- S** → Thickness of channel
- 2R** → Double radius

Sliding configurations

In case of sliding applications, the cable chain works in combination with other mechanical elements, so as the required performances increase (travel distance, speed, acceleration, duty cycles), the level of complexity increases.

Sliders

Our chain series for sliding applications are designed to minimise friction and wearing even with heavy loads. Therefore the sliders integrated into the link are made with low friction polymers to increase the contact surface.

In some series the sliders are easily removable so that:

- In case of maintenance, only the wearing parts have to be replaced, reducing the maintenance costs and increasing the working life of the system
- The sidebands and the sliders on the chain can use different polymers according to the different functions of the parts of the chain

The dimensions of the sliders allow the chain to keep itself stable. Even in applications with high accelerations.

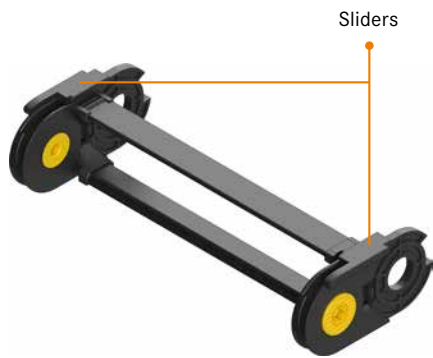

Upon request, it is possible to produce cable chains with special polyamides for applying in particularly aggressive environments. Ask our technical office for additional information.

INFOBOX

In order to achieve the best functionality result the distance between the fixed point of the cable chain and the beginning of the supports mounted on the extended side of the guide channel has to be as small as possible - however not more than 500 mm.

The materials available for the channels are: Zinc-plated steel, stainless steel AISI 304 or 316L, Aluminum.

Sliding with single chain

To properly operate in sliding configuration, the cable chains require the use of a guide channel.

chain slides on itself, while the extended side of the travel distance is supported by suitable supports mounted directly on the side of the guide channel.

In single chain applications, along the retracted side of the travel distance the

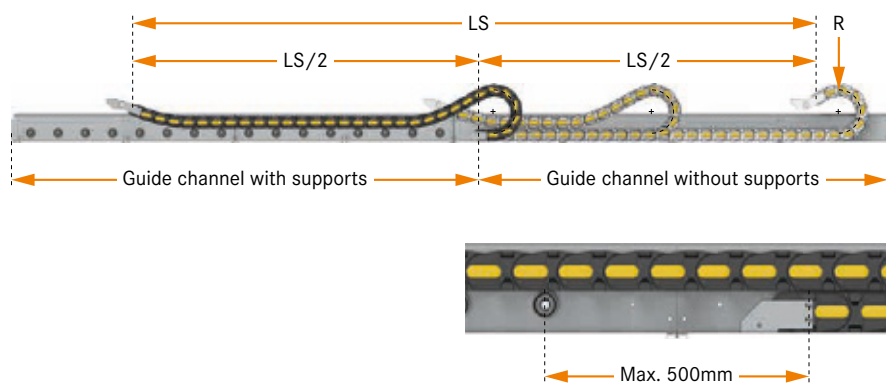

Sliding with multiple chains

In applications with two cable chains in ring configuration, the chains slide on themselves in both directions, so there are

no supports along the entire guide channel (except between the two fixed points, in case they are far away from each other).

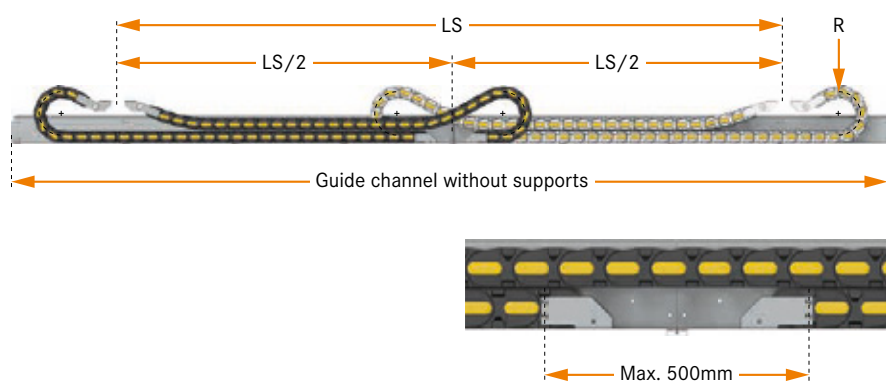

Avoiding friction

In case of long travel sliding systems, the main functions of the accessories are:

- Guidance and reduction of friction of the cable chain during movement
- Guide channel to guide the cable chain and guarantee its alignment
- Misalignment recovery system (Fig. 1) for the mobile point in order to reduce the friction between the sidebands of the chain and the walls of the channel
- Wheel systems (mounted on the channel and/or on the chain) to further reduce the friction between the upper and the lower part of the cable chain

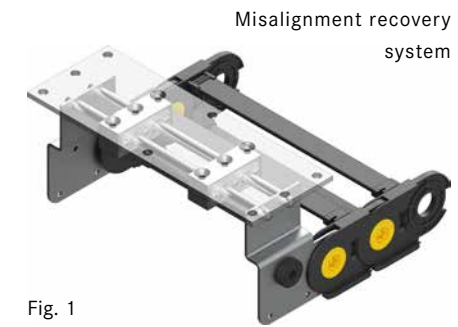

Fig. 1

Correct mounting of guiding channels

It is very important that the cable chain can move freely along the whole travel length. To guarantee optimal and friction-free guidance of the cable chain, the guiding channel must be mounted:

- As level as possible (both in longitudinal and transversal direction (Fig. 2) – to avoid additional friction between the upper chain and the lower chain (or the supports) or to avoid possible lifting of the cable chain
- As straight as possible to avoid friction between the sidebands and the walls of the channel (Fig. 3)

Despite the precautions taken in the assembly phase, it may be that the channel is not aligned with the movement of the towing arm. If the maximum disalignment between the guide channel line and the movement of the towing arm is bigger than $\pm 4\text{mm}$ (Fig. 4), it is necessary to recover this gap using a misalignment recovery system mounted on the mobile point of the cable chain (Fig. 1).

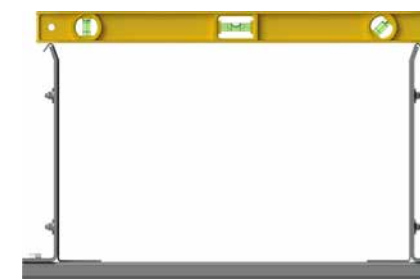

Fig. 2

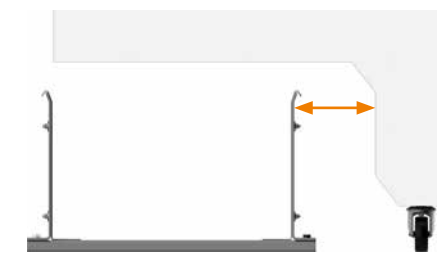

Fig. 3

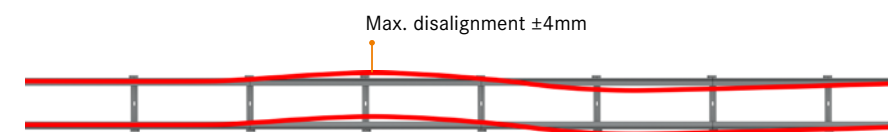



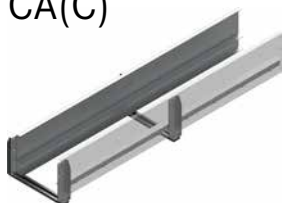
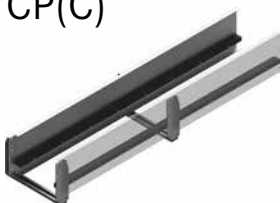
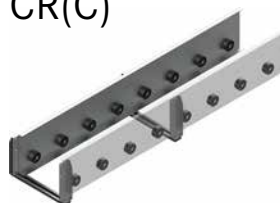

Fig. 4

Different channel options

	Retracted side	Extended side		
Open channels	without supports CS 	with angulars CA 	with glide profiles CP 	with wheels CR 
Closed channels		CA(C) 	CP(C) 	CR(C) 

i Steel closed channels can be used (on the extended side of the travel distance only) to prevent possible lifting of the chain. Suggested for travel distances LS >40 -50m.

	CA(C) Angular	CP (C) Profiles	CR (C) Wheels
Friction	***	**	*
Noise	**	*	***
Price	*	***	**

(C) = closed · ***= high → * = low



Vertical application

Vertical application means that the direction of motion is vertical and the arc of the chain radius doesn't touch the ground or the ceiling.

There are two different options

- Hanging applications → the chain is suspended and the arc of the chain radius is at the bottom (**Fig. 1**)
- Standing applications → the arc of the chain radius moves upward on top of the chain (**Fig. 2**)

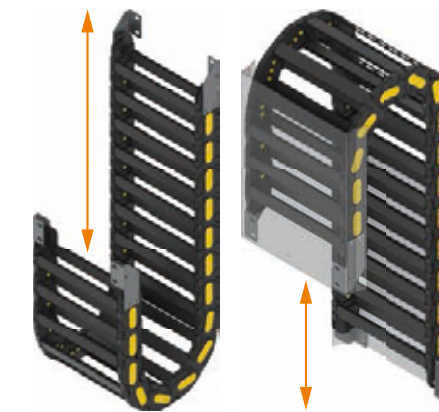

Fig. 1

Fig. 2

Cable fixation

In all the vertical applications

- chain's only function is to contain and protect cables and hoses. The utilities should bear their own weight without loading the chain
- Cables/hoses have to be fixed on both ends using the appropriate accessories (strain relief) and should not touch the cable chain (**Fig. 3**)
- Locking end brackets should be used

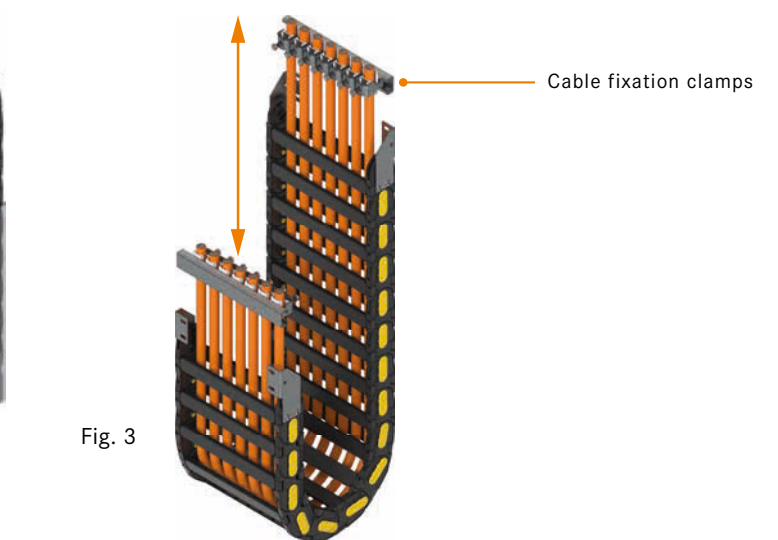

Fig. 3

Hanging applications

A cable chain is far less stressed and more stable in a hanging application. In addition, transversal accelerations can happen (in the event of side winds or if the cable chain is installed on moving machinery). The following must be considered:

- If the application only concerns a vertical movement, the cable chain does not need any specific support
- If the chain is affected by transversal accelerations (**Fig. 4**), a support (guide trough) is required
- For special applications, frames with completely closed guiding systems are available

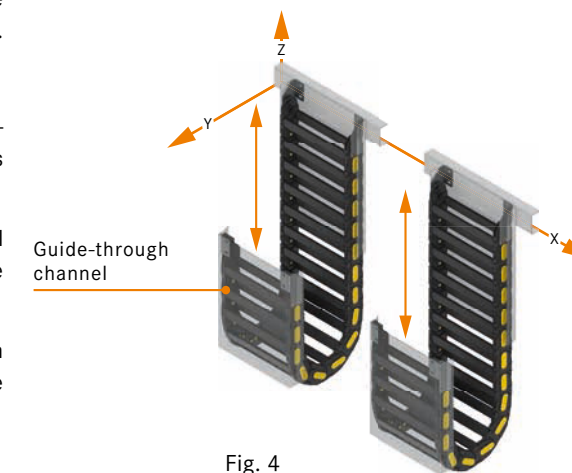

Fig. 4

Vertical applications at a glance

	Vertical hanging applications	Vertical standing applications
Working parameters	Max. travel length: 100m	Max. travel length (without support): 4m Max. travel length (with support): 6m Max. travel length (with full support): 14m
Pre-set (Pr)	A normal chain with pre-set can be used, if there is enough space for the installation. In case of reduced available space, a chain without pre-set must be used*.	A normal chain should be used, and the customer should consider the pre-set in calculating the space for the installation.
Installation space**	Without pre-set: $2x(R + S) + B$	With pre-set: $2x(R + S + Pr) + B$
Layout	<ul style="list-style-type: none"> Layout of cables/hoses inside the cross section is secondary, since they are strain relieved and suspended on both ends Separations inside the cross section are not mandatory but suggested 	<ul style="list-style-type: none"> The layout of cables/hoses inside the cross section is symmetrical and should be strain relieved at both ends and stand without loading the chain Vertical separators are recommended to allow the utilities to move freely inside the chain

*Our recommendation: vertical applications without pre-set.

** R = Chain bending radius
Pr = Chain pre-set
S = Thickness of the guide trough channel
B = Outside height of the chain

Side mounted configurations

Side mounted application means that the chain works mounted on its side. This configuration becomes necessary when there is a limited space upwards and mounting the cable chain would normally take up too much space, or when the additional load of the utilities exceeds the maximum self-supporting capability of the chain but for some reason the sliding configuration cannot be used.

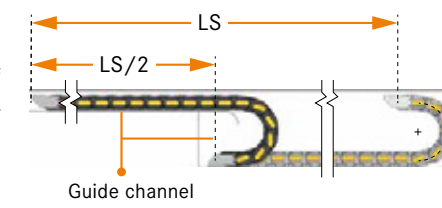

Fig. 1

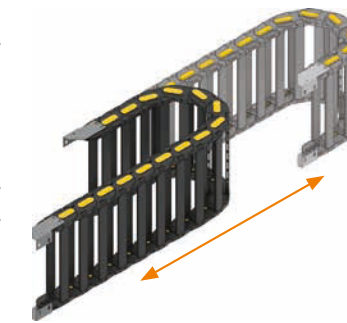

Fig. 2

The following options are available:

- Supported applications where the cable chain is moving on a floor, inside a guide channel (Fig.1), for example in long travel distance applications
- Suspended applications where the cable chain is not supported from the bottom, for example in machine tools. In this case at least the first three links near both the mobile and the fixed point should be supported from the bottom (Fig. 2), depending on factors like travel distance, additional load, unsupported length. Note: this configuration can place excessive stress on the cable chain

In a supported application, to have a smooth movement and reduce the friction between the cable chain and the carpentry floor, the use of anti-friction skirts or pivoting wheels is recommended (Fig. 3)

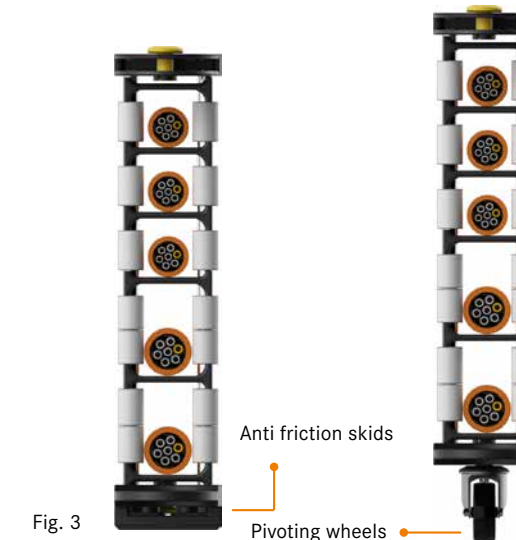

Fig. 3

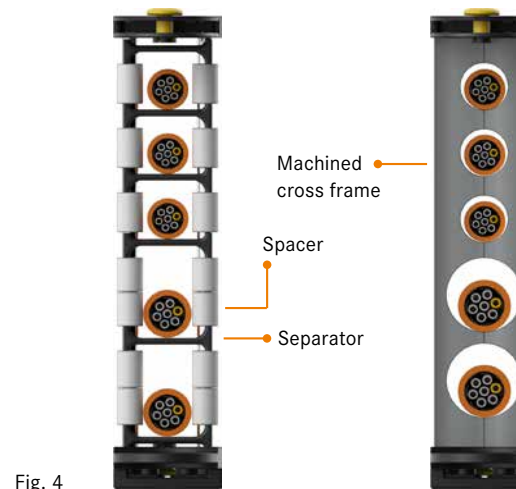

Fig. 4

Fig. 5

i Since pivoting wheels reduce the stability of the cable chain they must be used in combination with a guidance system

Spacers

Particular attention should be paid to determine the section of the cable chain. In fact, mounting the chain on its side means that cables/hoses have a tendency to bunch towards the ground and get squashed. To avoid this, spacers can be mounted between the vertical separators (and the utilities) in position (Fig. 4). The vertical separators (and their fixation to the cross frames) are also designed to resist cables' additional load. The heavier utilities should be positioned at the bottom to reduce the stress on the cross bars. In case of lay on side machined cross frames can also be used to hold in position the utilities and maintain them in line with the neutral axis of the chain reducing the stress (Fig. 5).

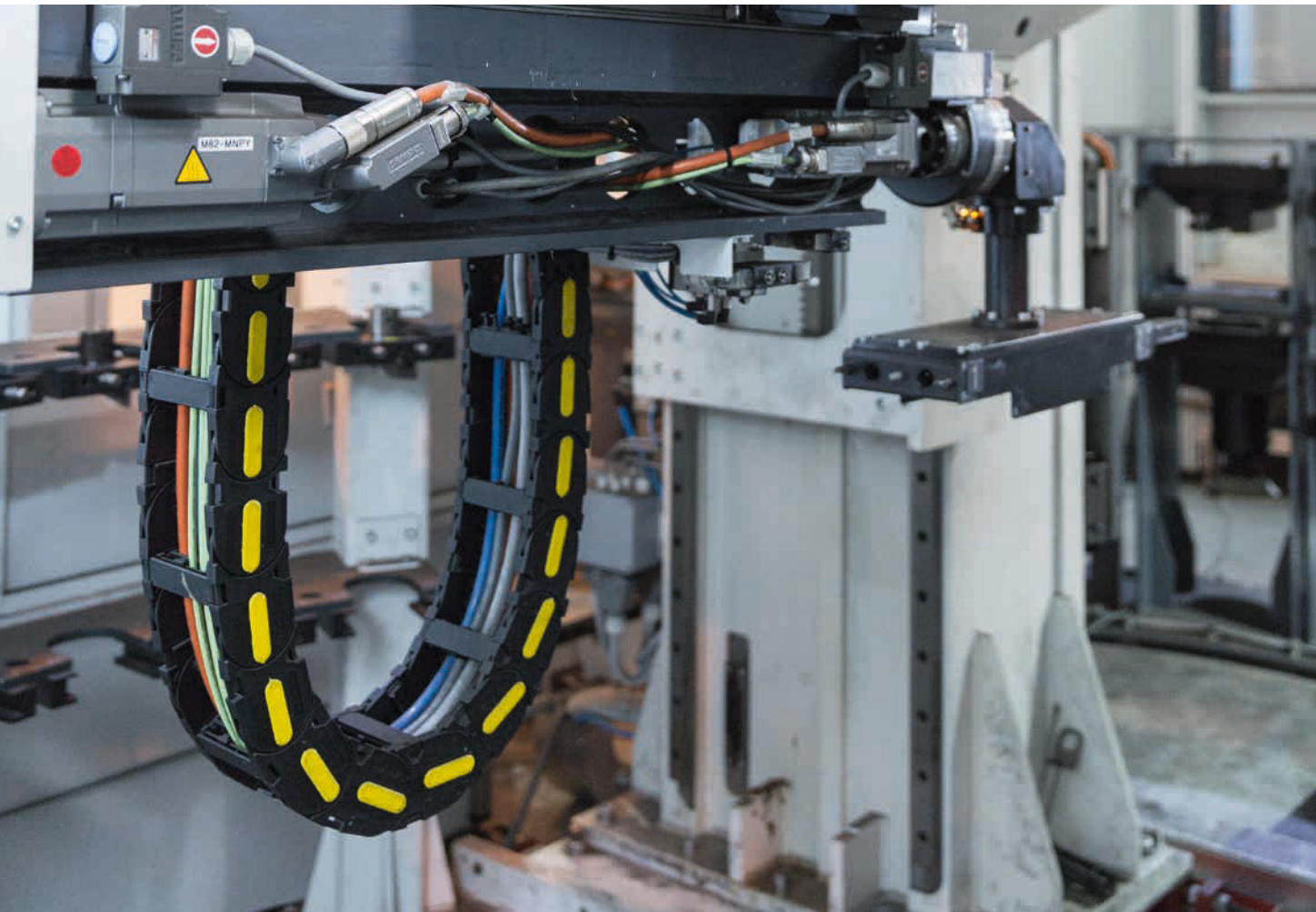

Rotary applications

The rotary configuration is a specific application that allows rotations between fixed and mobile points. This configuration is an alternative when the ROBOT series cannot be used (e.g. limited space conditions or incompatibility of the available diameters for the installation).

If the cable chain operates while mounted all the considerations made for the supported lay on side applications are still valid for the rotary one.

In this configuration, the cable chain links must rotate each other in both directions, so the chain has a bending radius and a counter bending radius (Fig.1). All chains (except the PROTECTION series) can be delivered with this counter-radius.

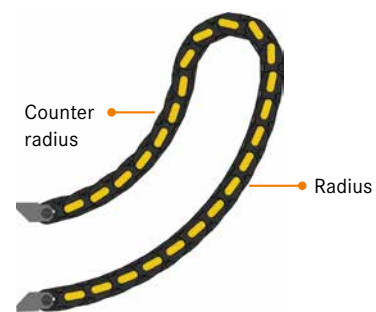

Fig. 1

Possible rotary configuration options (Fig. 2)

- For single applications, the chain is guided by the housing only. For multi chain applications, the chains are in a ring configuration (1 or 2 chains for each half ring) and are guided in their movement by an inner movable frame.

For applications with rotations over 180°, it is necessary to use a multi-chain configuration. The maximum rotation achievable depends on the system geometry. Rotation up to 600° could be possible.

- For fixed housing, the chain moving inside the housing is pulled and pushed by the towing arm, and there is sliding motion between the chain and the floor of the housing
- In movable housing, the housing is divided into two parts concentric to each other, one of which is fixed (connected to the fixed point of the chain) and the other is movable (connected to the mobile point of the chain). There is no relative movement between the chain and the housing, except for the links which are on the bending radius

i The movable housing option reduces the wearing of the links but requires a very precise installation to guarantee the planarity of the two floors of the housing (movable and fixed) and their concentricity. Whether the movable point is positioned inside or outside the diameter depends on the motion pattern of the application.

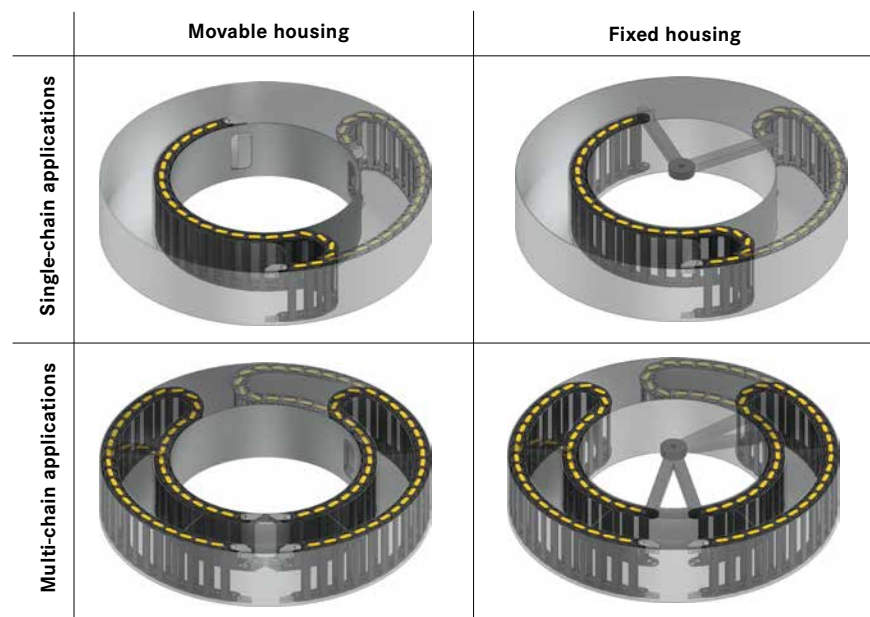

Fig. 2

Inner frames

Inner frame moves on anti-friction skids or pivoting wheels (Fig. 3) and, in combination with the guide housing, guarantees the guide of the chains

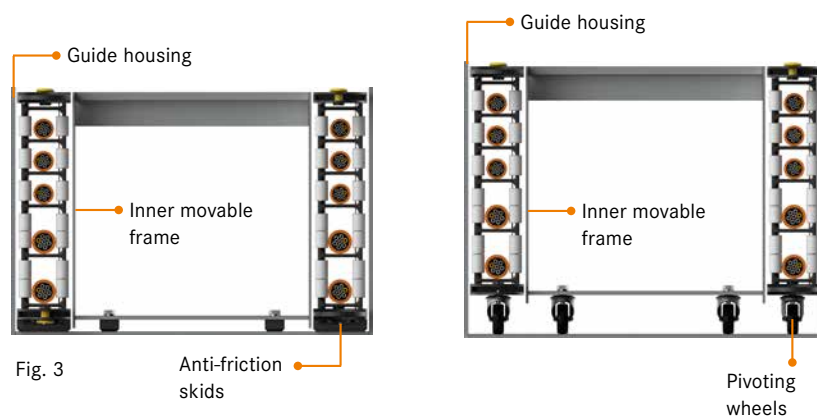

Fig. 3

Robot chain applications

The "ROBOT" chain series is a series that, due to the particular construction of the links, enables them to rotate around two axes in a natural way.

This concept is specifically designed for use in combination with anthropomorphic (= humanlike) robots, and allows rotation of up to 540°.

Basically the chain works like any other self-supporting or supported configuration, the only difference being that the movement of the mobile point is a rotation instead a translation (Fig. 1). The chains from the "ROBOT" series are self-supporting and they do not need any support up to 200°.

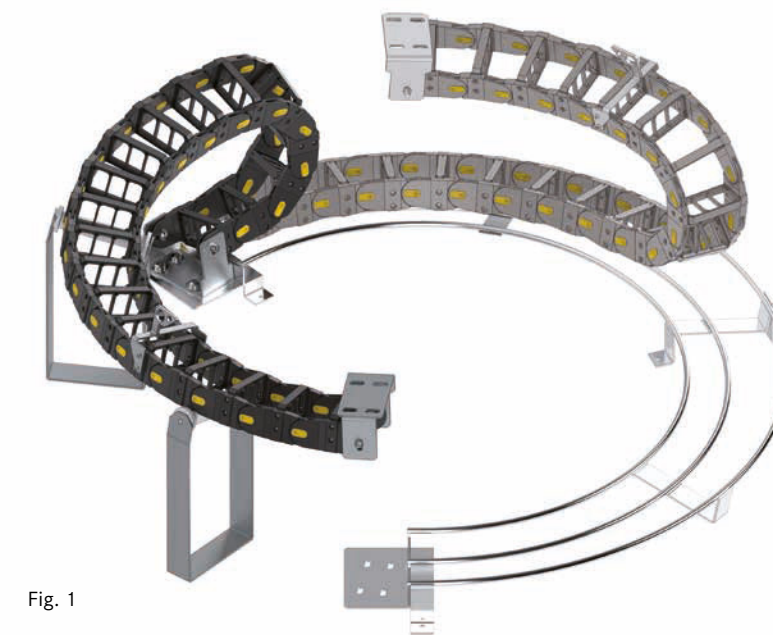

Fig. 1

Accessories

Applications with rotations require the use of their own appropriate accessories:

- Base cradle (Fig. 2), that functions as a channel guide in linear movement and guides the lower part of the cable chain.

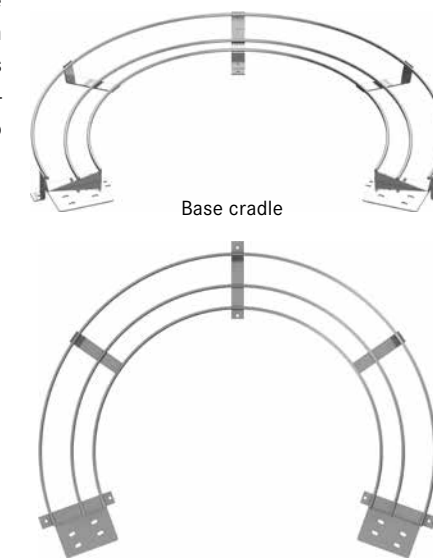

Fig. 2

For applications with rotations exceeding 200°, we have developed the following supports for guide the chain:

- Supporting rollers (Fig. 3) that can support the chain on the extended side of the travel distance
- Supporting hooks (Fig. 4) that can support the chain also on the retracted side of the travel distance



Fig. 3

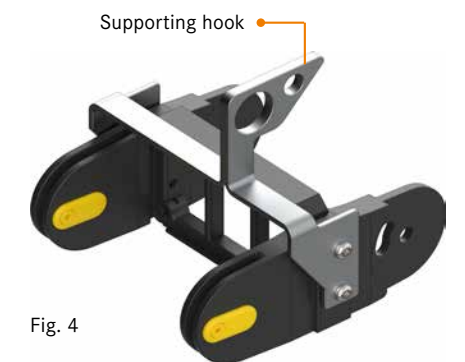

Fig. 4

i When the use of one cable chain is not sufficient to contain all the cables/hoses, it is possible to use several chains in the same application increasing the space holding them. The "ROBOT" chain series can be customised for special application needs. Please contact our technical office for more information.

ÖLFLEX® FD/CHAIN, UNITRONIC® FD, ETHERLINE® FD and HITRONIC® FD cables in cable chains

1. Power chains must be selected in accordance with the relevant project documentation of the chain manufacturers. The bending radius must comply with the minimum bending radius of the cables. If possible, we recommend avoiding a multi-layer cable configuration, i.e. >25 cores, and instead distributing the required quantity amongst several cables.

2. The cables must be unreeled from the ring or drum free of any twists (at a tangent) and must be laid out straight. This work should be carried out before starting the installation works so that the cables can relax in this time. Due to the manufacturing process, the markings on the cables run round in a gentle spiral. Therefore this cannot be used to ensure that the cables have been straightened out without any twists.

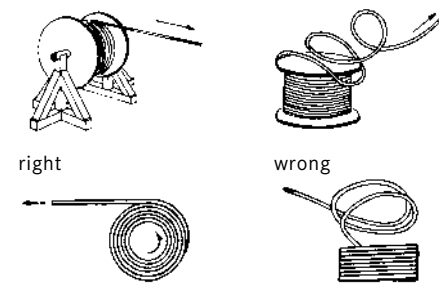

3. The cable temperature should not drop below +5 °C at any point during installation.

4. The cables also need to be installed without any twisting when inserted into the chambers. If a cable is twisted during installation, it can lead to premature damage to the core stranding. This effect can be reinforced during operation and result in so-called corkscrewing. This leads to core breaks, which ultimately cause malfunctions.

5. The cables must lie loosely next to each other in the chain chambers. They should be separated as much as possible using separators. The clearance between the cables and the cross bar, the separators or the neighbouring cables should be at least 10% of the cable diameter.

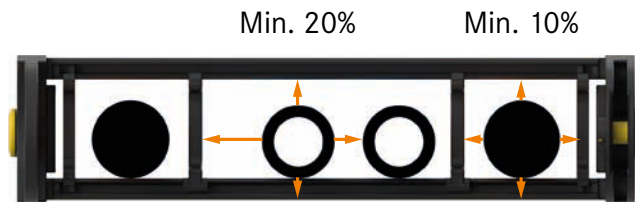

6. The cables should be installed symmetrically in terms of their weight and size; those with greater diameters and weights on the outside, those with smaller diameters and weights on the inside. They can also be placed in descending size order from inside to outside. Avoid arranging the cables above one another without the use of a shelf.

7. If the chain configurations are suspended vertically, additional free space must be provided in terms of the stay height, as the cables are lengthened during operation. After a short period of operation time, it is important to check whether the cables are still running along the neutral zone. It may be necessary to readjust them.

8. With self-supporting chain configurations, a cable is fastened both to the moving point and to the fixed point. Suitable cable supports of the chain manufacturer should be used here. With high accelerations, cable ties only have limited suitability. Avoid tying multiple cables together. The cables must not be secured or in any way bound together in the moving part of the chain. The clearance between the fixed point and the bending movements should be sufficiently wide.

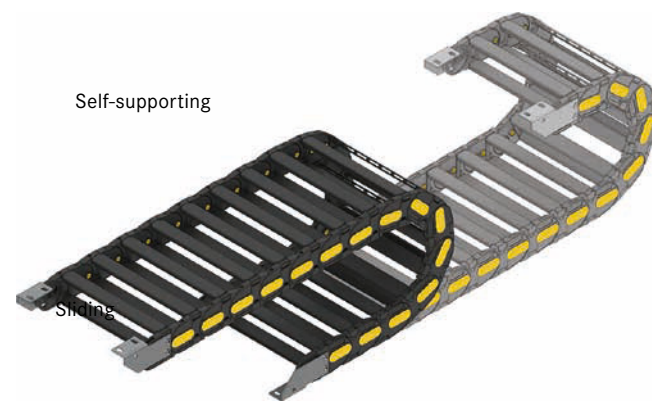

9. With sliding chains, we recommend that the cable only be fastened to the moving point. A small cable reserve should be factored in at the fixed point. (Note the assembly instructions of the chain manufacturer).

10. Make sure that the cables in the bending radius run in the neutral zone, i.e. there must be no forced guidance through the chain in the inner or outer radius, so that the cables can still move relative to one another and to the chain. (Fig. 1)

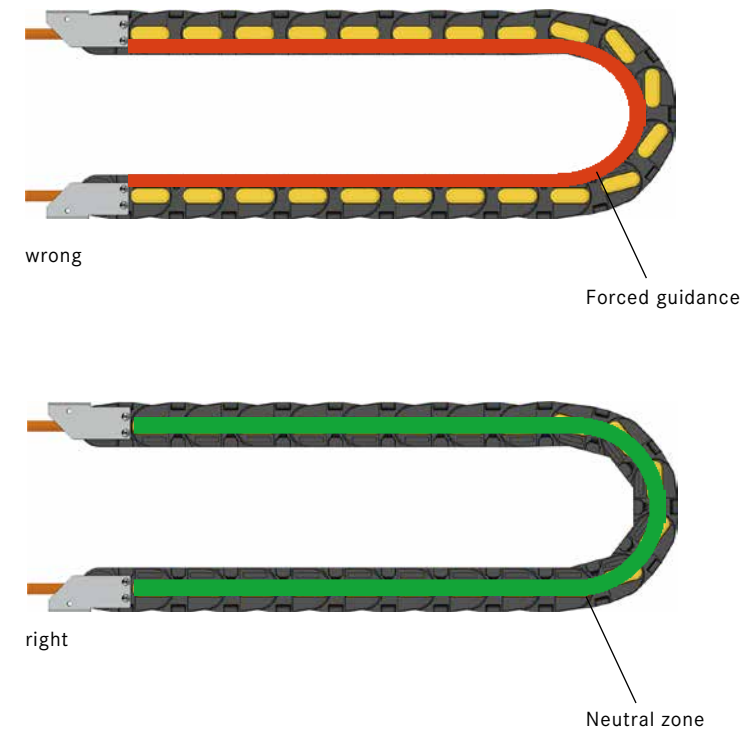

11. If a cable does not run smoothly, i.e. if it becomes twisted along the longitudinal axis during operation, the cable should be rotated gradually at one of the fastening points until it runs smoothly again.

12. The length-changing characteristics of a cable and a chain differ considerably from one another in terms of their absolute sizes. In the first few hours of operation, cables undergo natural lengthening. With chains, it takes many hours of operation for this effect to take place. This oppositional behaviour should be addressed by regularly checking the installation position of the cables. We recommend carrying out the inspections regularly, every three months, in the first year of operation – after they should be carried out whenever a maintenance interval is due. This involves checking that the cables in the bending radius can move completely freely. It may be necessary to make readjustments. We recommend incorporating the maintenance instructions into the inspection plan of the system.

13. The travel distance (LS) results from 2 x chain length (L)

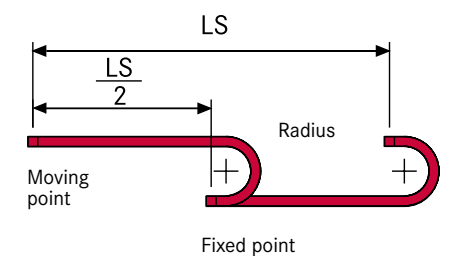

Product selection



Page	Chain series	Inner width		Inner height mm	Outer width		Outer height mm
		from mm	to		from mm	to	
56	SILVYN® CHAIN 200	12	35	12	18	41	15
58	SILVYN® CHAIN 250L/LI/LE	15	50	17	26	61	23
64	SILVYN® CHAIN 325L/LI/LE	40	103	25	57	120	38
70	SILVYN® CHAIN 325PI	10	103	25	57	120	38
72	SILVYN® CHAIN 335L/LI/LE	40	150	35	56,5	166,5	50
78	SILVYN® CHAIN 335PS	40	150	35	56,5	166,5	50
80	SILVYN® CHAIN 445MU	50	362	45	72	384	64
82	SILVYN® CHAIN 445PU	50	362	45	72	384	64
84	SILVYN® CHAIN 445AU	50	362	45	72	384	64
86	SILVYN® CHAIN 445PS	61	125	45	83	147	64
88	SILVYN® CHAIN 660A	50	362	37	75	387	55
90	SILVYN® CHAIN 660	50	150	36	79	179	55
92	SILVYN® CHAIN 770A	45	357	60	80	392	78
94	SILVYN® CHAIN 770	85	250	51	120	285	78
96	SILVYN® CHAIN 475MU	74	498	75,5	112	536	100,5
98	SILVYN® CHAIN 475PU	74	374	75,5	110	410	100,5
100	SILVYN® CHAIN 306SU	43	355	37	79	391	55
102	SILVYN® CHAIN 306CU	43	355	37	79	391	55
104	SILVYN® CHAIN 306B	75	300	30	115	340	55
106	SILVYN® CHAIN 307SU	42	354	47	80	392	65
108	SILVYN® CHAIN 307B	75	300	40	117	342	65
110	SILVYN® CHAIN 307E	75	300	46,5	113	338	65
112	SILVYN® CHAIN 308SU	38	350	57	82	394	75
114	SILVYN® CHAIN 308CU	38	350	57	82	394	75
116	SILVYN® CHAIN 308B	100	300	48	156	356	75
118	SILVYN® CHAIN 308E	100	300	56,5	144	344	75
120	SILVYN® CHAIN 309SU	64	400	75,5	120	456	100
122	SILVYN® CHAIN 309CU	64	488	75,5	120	544	100
124	SILVYN® CHAIN 309B	100	400	70	156	456	100
126	SILVYN® CHAIN 309T	100	400	73	156	456	100
130	SILVYN® CHAIN H57SC	75	500	57	113	538	85
132	SILVYN® CHAIN H57PN	150	250	53,5	188	288	85
132	SILVYN® CHAIN H57PC	75	400	53,5	113	438	85
134	SILVYN® CHAIN H57B	100	400	57	138	438	85
136	SILVYN® CHAIN H57T	100	400	57	138	438	85
138	SILVYN® CHAIN H80SA	64	400	80	120	456	100
140	SILVYN® CHAIN H80PA	74	498	77	129	553	114
142	SILVYN® CHAIN H80B	100	500	81	155	555	114
144	SILVYN® CHAIN H80T	100	500	81	155	555	114
146	SILVYN® CHAIN H110SC	200	600	112	260	660	150
148	SILVYN® CHAIN H110PC	200	498	105	255	553	155
150	SILVYN® CHAIN H110B	200	600	112	255	655	155
152	SILVYN® CHAIN H110T	200	600	112	255	655	155
166	SILVYN® CHAIN 326SU	61	373	37	89	416	59
168	SILVYN CHAIN 326B	75	300	37	115	340	59
170	SILVYN® CHAIN 328SU	61	373	57	116	428	79
172	SILVYN® CHAIN 328B	100	300	48	162	362	79
174	SILVYN® CHAIN 329SU	64	488	75,5	128	552	107
176	SILVYN® CHAIN 329CD	64	488	75,5	128	552	107
178	SILVYN® CHAIN 329B	100	400	70	164	464	107
180	SILVYN® CHAIN 478MU	74	498	75,5	112	536	106,5
182	SILVYN® CHAIN 478PU	74	498	75,5	112	536	106,5
184	SILVYN® CHAIN 60PU	115	539	60,5	165	589	90
186	SILVYN® CHAIN 60VU	115	539	60,5	165	589	90
188	SILVYN® CHAIN 80PU	115	539	80,5	195	619	117
200	SILVYN® CHAIN 20LT	79	304	32	111	336	53
202	SILVYN® CHAIN 20LC	79	304	32	111	336	53
204	SILVYN® CHAIN 30LT	106	506	52	140	540	74
206	SILVYN® CHAIN 30LC	106	506	52	140	540	74
208	SILVYN® CHAIN 35LT	104	504	65	148	548	95
210	SILVYN® CHAIN 35LC	104	504	65	148	548	95
212	SILVYN® CHAIN 40LT	150	500	112,5	208	558	145
214	SILVYN® CHAIN 40LC	150	500	112,5	208	558	145
216	SILVYN® CHAIN 42LT	150	500	138	208	558	175
218	SILVYN® CHAIN 45T	300	600	182	390	690	220
220	SILVYN® CHAIN 20LPT	79	304	32	121	346	58,5
222	SILVYN® CHAIN 20LPC	79	304	32	121	346	58,5
224	SILVYN® CHAIN 30LPT	106	506	52	151	551	81,5
226	SILVYN® CHAIN 30LPC	106	506	52	151	551	81,5
228	SILVYN® CHAIN 35LPT	104	504	65	148	548	107
230	SILVYN® CHAIN 35LPC	104	504	65	148	548	107
232	SILVYN® CHAIN 40LPT	150	500	112,5	230	580	161,5
234	SILVYN® CHAIN 40LPC	150	500	104	230	580	161,5
236	SILVYN® CHAIN 42LPT	150	500	138	230	580	191,5
246	SILVYN® CHAIN 495	45	-	35	69	-	45
248	SILVYN® CHAIN 500	65	-	30	93	-	43
250	SILVYN® CHAIN 510TN	88	-	46	132	-	55
250	SILVYN® CHAIN 515TN	88	-	46	132	-	55
252	SILVYN® CHAIN 545	62	-	46	123	-	62
254	SILVYN® CHAIN 599	210	-	59	272	-	85

Pitch mm	Bending radius		Self supporting capacity		Sliding application	Protection cover
	from mm	to mm	max m	kg		
17	18	40	0,9	0,1		
29	28	100	1,3	0,1		
45	50	150	1,9	0,5	on request	
45	75	150	1,7	0,5		✓
52	65	200	2,2	1	on request	
52	65	200	2,0	1		✓
67	75	300	3,7	1	on request	
67	100	300	3,4	1		✓
67	100	300	3,4	1		✓
67	100	300	3,4	1	on request	✓
50	100	250	2,5	1	on request	
50	100	250	2,3	1		✓
70	150	300	3,8	1	on request	
70	150	300	3,5	1		✓
105	150	400	4,8	1	on request	
105	180	400	4,5	1		✓
65	75	300	2,7	1		✓
65	107	300	2,7	1		✓
65	75	300	3,1	1		
70	75	250	3,2	1		
70	75	250	3,9	1		
70	75	250	3,2	1		
80	135	400	4,2	1		
80	150	400	4,0	1		✓
80	150	400	5,0	1		
80	135	400	4,2	1		
100	150	600	6,5	1		
100	200	500	5,8	1		✓
100	150	600	4,6	1		
100	150	600	4,6	1		
90	150	400	5,0	1		
90	180	400	4,8	1		✓
90	180	400	4,8	1		✓
90	180	400	5,0	1		
90	180	400	5,0	1		
120	200	750	7,0	1		
120	200	600	6,0	1		✓
120	200	600	7,0	1		
120	200	600	7,0	1		
160	200	750	9,0	1		
160	250	750	7,8	1		✓
160	200	750	9,0	1		
160	200	750	8,0	1		
65	107	300	-	-	✓	
65	107	300	-	-	✓	
80	150	400	-	-	✓	
80	150	400	-	-	✓	
100	150	600	-	-	✓	
100	200	600	-	-	✓	✓
100	150	600	-	-	✓	
105	150	400	-	-	✓	
105	180	400	-	-	✓	✓
90	150	400	-	-	✓	
90	150	400	-	-	✓	
110	200	700	-	-	✓	
75	75	305	4,2	1		
75	115	305	4,2	1		✓
95	150	535	5,8	1		
95	150	535	5,8	1		✓
125	200	600	7,8	1		
125	200	600	7,0	1		✓
180	250	850	12,9	1		
180	250	850	11,8	1		✓
180	250	850	12,0	1		
250	400	1500	13,0	1		
75	115	305	-	-	✓	
75	115	305	-	-	✓	✓
95	150	535	-	-	✓	
95	150	535	-	-	✓	✓
125	200	600	-	-	✓	
125	200	600	-	-	✓	✓
180	250	850	-	-	✓	
180	250	850	-	-	✓	✓
180	250	850	-	-	✓	
-	100	-	-	-		
-	100	150	-	-		
-	125	-	-	-		
-	175	-	-	-		
-	100	-	-	-		
-	220	-	-	-		