

# Serie Steel

## BS2000

### Cable Chains in Bright Zinc Plated Steel

Inner height (D) 32 mm  
 Double share link construction.  
 Single-rievt fixing and standard large washer and nylon anti-friction disk to assure durable smooth movement.  
 Alu-draw frames (T) or Alu-drilled plates (TL) are un-screwable from both sides.  
 As standard the frames every second link, on request every link.  
 Vertical and horizontal separator systems are available.  
 Also available in Stainless Steel.

#### Technical characteristics when self-supported

Speed	0,5 m/s
Acceleration	2 m/s <sup>2</sup>

For higher requirements please consult our technical dept.

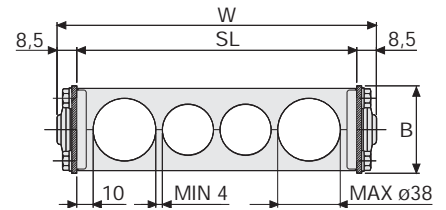
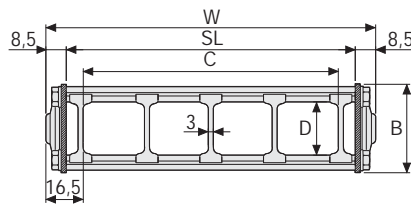

#### Separator

- Unassembled	Part.no S306CO
- Assembled	Part.no S306COMC

#### Aluminium Draw Plates with Separators in Nylon

W	B	C	D	R	Weight/m	Chain
mm	mm	mm	mm	mm	kg	Part Number
112	53	79	32	075-115-150-205-250-305	4,90	2000NT079□□□*
137	53	104	32	075-115-150-205-250-305	5,00	2000NT104□□□*
187	53	154	32	075-115-150-205-250-305	5,30	2000NT154□□□*
237	53	204	32	075-115-150-205-250-305	5,60	2000NT204□□□*
287	53	254	32	075-115-150-205-250-305	5,80	2000NT254□□□*
337	53	304	32	075-115-150-205-250-305	6,10	2000NT304□□□*
C+33	53	....	32	075-115-150-205-250-305		2000NT □□□□□**

\*Complete the code by inserting the value of the radius (R): Ex. 2000NT154 □□□□

\*\*Complete the code by inserting the value of the quote C and the radius (R): Ex. 2000NT □□□□□□□

Chain equipped with aluminium draw plates every pitch: complete the code by inserting the letter D.  
 Ex. 2000NT154250 □

#### Aluminium Split Cross Piece Created by Design

W	B	R	Chain
mm	mm	mm	Part Number
SL+17	53	075-115-150-205-250-305	2000NTL □□□□□□***

\*\*\*Complete the code by inserting the value SL and the radius (R): Ex. 2000NTL □□□□□□□

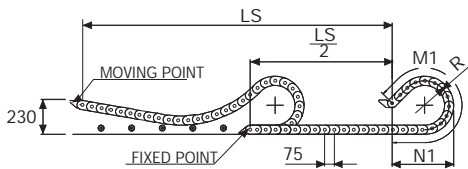
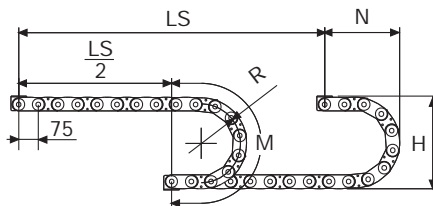

Length of chain (L)  
 Half travel distance ( $\frac{LS}{2}$ )  
 plus length of curve (M)

$$L = \frac{LS}{2} + M \text{ or } M1$$

R	H*	N	M	N1	M1
mm	mm	mm	mm	mm	mm
075	214	180	390	-	-
115	294	220	515	500	1080
150	364	255	625	675	1485
205	474	310	795	885	2005
250	564	360	940	1030	2385
305	674	410	1110	1190	2825

\* The height H should be increased by 10 mm/m approx. because of preload. In case of limitation to the available space, refer to the Technical Dptm.



### Self-Supporting Capacity Diagram

The maximum length of the self-supporting capacity ( $\frac{LS}{2}$ ) in relationship to the weight of the cables and hoses contained per linear metre.

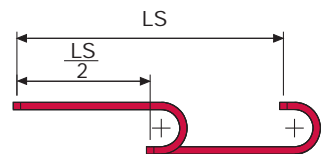
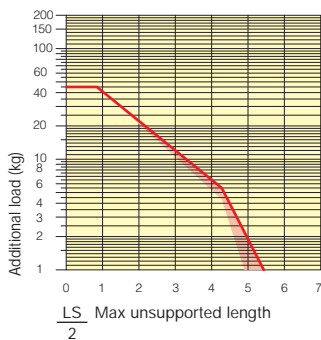

The red marking in the diagram area considers the difference of weight between various widths of chains assembled with aluminium draw plates every second pitch.

For applications with  $\frac{LS}{2}$  and weights not included in the area of the diagram showing self-supporting capacity, verify the possible use of support rollers (see page 30).

### Bright Zinc Plated Steel End Brackets

The end brackets set, containing four steel plates screwed to the links allows the two ends of the chain to be attached to the equipment.

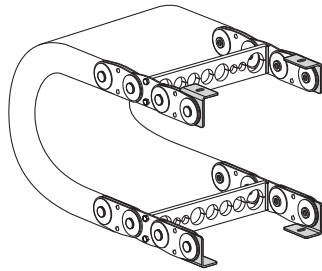
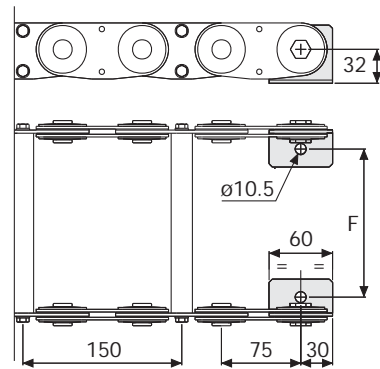

Fig. A  
The chain can be fixed frontally, inner or outer radius. (Fig A)



Chain Type	F mm
BS2000NT079	65
BS2000NT104	90
BS2000NT154	140
BS2000NT204	190
BS2000NT254	240
BS2000NT304	290

Special dimension F=W-47

### Bright Zinc Plated Steel Type Part Numbers

Complete Set Assembled	
Chain Type	End Brackets Set
BS2000...	A2000NKM

Complete Set Unassembled	
Chain Type	End Brackets Set
BS2000...	A2000NK

### Serie Steel

## BS2000

Cable Chain  
in Bright Zinc Plated Steel



Suitable to long travel distance.  
See page 194

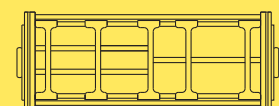

Supplementary movable separators.

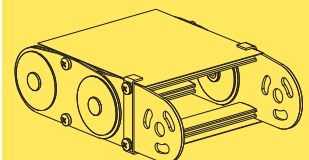

Steel laminar cover.

For further information please consult Brevetti Stendalto's Technical Office