

Serie Sliding

M60PIS/M60PES

Nylon Cable Chain with openable frames

Inner height (D) 60,5 mm
 Sideband & Frame construction with large anti-friction single-pin.
 Frames openable from inner radius (.PI) and outer radius (.PE).
 As standard the chain comes with frames every second link, on request with frames every link.
 Vertical separators are available

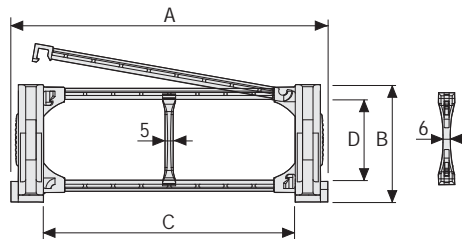

Separator	
- Unassembled	Part.no S60SM
- Assembled	Part.no S60SMMC
Strong-hold separator for C > 250 mm	
- Unassembled	Part.no S60HOFL
- Assembled	Part.no S60HOFLMC
Pin	
	Part.no PNE60S-PGI60S

Technical characteristics

Speed	5 m/s
Acceleration	13 m/s ²

For higher requirements please consult our technical dept.

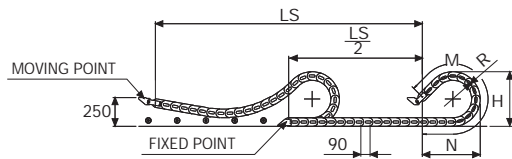

Length of chain (L)

Half travel distance ($\frac{LS}{2}$)
 plus length of curve (M)

$$L = \frac{LS}{2} + M$$

R	H	N	M
mm	mm	mm	mm
200	490	795	1760
250	590	1130	2505
300	690	1460	3245
400	890	2130	4730

A	B	C	D	R	Weight/m	Chain
mm	mm	mm	mm	mm	kg	Part number
169	96	115	60,5	200-250-300-400	5,37	M60PIS(PES)115 □□□ *
189	96	135	60,5	200-250-300-400	5,46	M60PIS(PES)135 □□□ *
214	96	160	60,5	200-250-300-400	5,52	M60PIS(PES)160 □□□ *
221	96	167	60,5	200-250-300-400	5,54	M60PIS(PES)167 □□□ *
244	96	190	60,5	200-250-300-400	5,61	M60PIS(PES)190 □□□ *
284	96	230	60,5	200-250-300-400	5,77	M60PIS(PES)230 □□□ *
319	96	265	60,5	200-250-300-400	5,91	M60PIS(PES)265 □□□ *
345	96	291	60,5	200-250-300-400	5,99	M60PIS(PES)291 □□□ *
369	96	315	60,5	200-250-300-400	6,07	M60PIS(PES)315 □□□ *
395	96	341	60,5	200-250-300-400	6,17	M60PIS(PES)341 □□□ *
419	96	365	60,5	200-250-300-400	6,26	M60PIS(PES)365 □□□ *
445	96	391	60,5	200-250-300-400	6,34	M60PIS(PES)391 □□□ *
469	96	415	60,5	200-250-300-400	6,43	M60PIS(PES)415 □□□ *
593	96	539	60,5	200-250-300-400	7,08	M60PIS(PES)539 □□□ *

*Complete the code by inserting the value of the radius (R): Ex. M60PIS(PES)115 □ □ □ □
 Chain equipped with nylon frame every pitch: complete the code by inserting the letter D.
 M60PIS(PES)115250 □

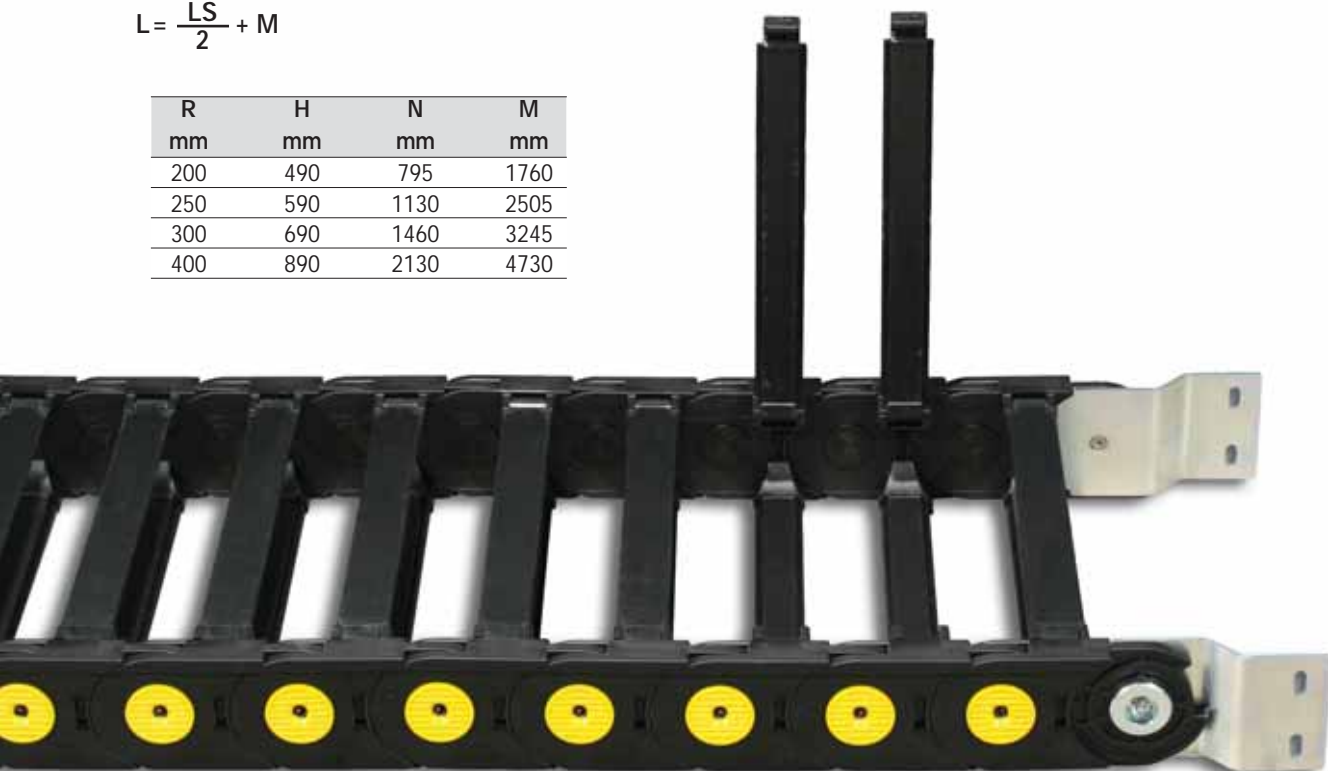

End Brackets

The end brackets set allows the two ends of the chain to be attached to the equipment. One set comprises two movable end brackets to install at the moving point and two standard steel end brackets to install at the fixed point.

Bright Zinc Plated Steel Movable Type* (fixed point) Bright Zinc Plated Steel Type* (moving point)

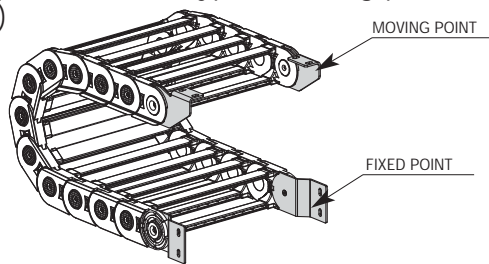
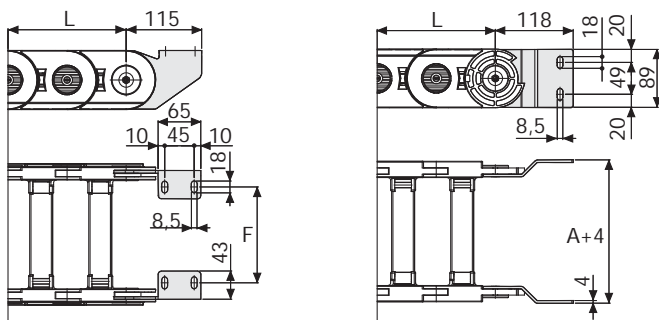

Fig. A
Chain fixed outside the radius. (Fig A)



Chain Type	F mm
M60PIS(PES)115	95
M60PIS(PES)135	115
M60PIS(PES)160	140
M60PIS(PES)167	147
M60PIS(PES)190	170
M60PIS(PES)230	210
M60PIS(PES)265	245
M60PIS(PES)291	271
M60PIS(PES)315	295
M60PIS(PES)341	321
M60PIS(PES)365	345
M60PIS(PES)391	371
M60PIS(PES)415	395
M60PIS(PES)539	519

Bright Zinc Plated Steel Type Part Numbers

Complete Set Assembled	
Chain	End Brackets
Type	Set
M60PIS/PES...	A60PKM

Complete Set Unassembled	
Chain	End Brackets
Type	Set
M60PIS/PES...	A60PK

*Available on request in stainless steel

Serie Sliding

M60PIS

M60PES

Nylon Cable Chain with openable frames

3

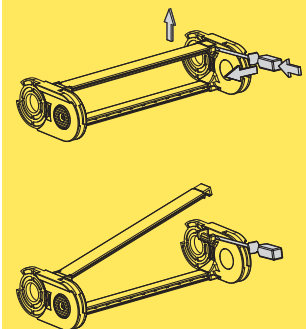

How to open the cover.

For further information please consult Brevetti Stendaito's Technical Office