

Serie Protection

SR306CI/SR306CE

Nylon Protection Cable Chain
with openable aluminium covers

Inner height (D) 37 mm
Strong double share Sideband & Frame
construction with large anti-friction
triple-pin.
Covers are openable from inner radius
(SR306CI) or from outer radius
(SR306CE).
Vertical separators are available.

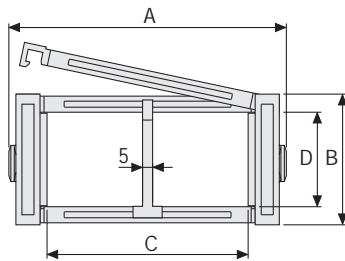

Separator	
- Unassembled	Part.no S306SM
- Assembled	Part.no S306SMMC
Pin	
	Part.no PG307

Technical characteristics when self-supported

Speed	8 m/s
Acceleration	40 m/s ²

For higher requirements please consult our
technical dept.

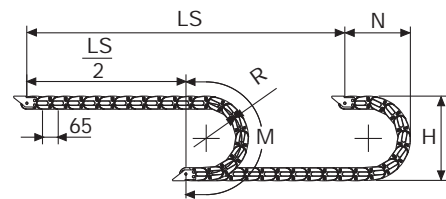

Length of chain (L)
Half travel distance ($\frac{LS}{2}$)
plus length of curve (M)

$$L = \frac{LS}{2} + M$$

A	B	C	D	R	Weight/m	Chain
mm	mm	mm	mm	mm	kg	Part Number
79	55	43	37	107-150-200-250-300	1,85	SR306CI(CE)043□□□*
90	55	54	37	107-150-200-250-300	1,90	SR306CI(CE)054□□□*
104	55	68	37	107-150-200-250-300	2,04	SR306CI(CE)068□□□*
110	55	74	37	107-150-200-250-300	2,09	SR306CI(CE)074□□□*
124	55	88	37	107-150-200-250-300	2,20	SR306CI(CE)088□□□*
129	55	93	37	107-150-200-250-300	2,22	SR306CI(CE)093□□□*
136	55	100	37	107-150-200-250-300	2,27	SR306CI(CE)100□□□*
146	55	110	37	107-150-200-250-300	2,33	SR306CI(CE)110□□□*
154	55	118	37	107-150-200-250-300	2,42	SR306CI(CE)118□□□*
165	55	129	37	107-150-200-250-300	2,50	SR306CI(CE)129□□□*
179	55	143	37	107-150-200-250-300	2,61	SR306CI(CE)143□□□*
204	55	168	37	107-150-200-250-300	2,80	SR306CI(CE)168□□□*
229	55	193	37	107-150-200-250-300	3,00	SR306CI(CE)193□□□*
240	55	204	37	107-150-200-250-300	3,08	SR306CI(CE)204□□□*
254	55	218	37	107-150-200-250-300	3,19	SR306CI(CE)218□□□*
281	55	245	37	107-150-200-250-300	3,40	SR306CI(CE)245□□□*
290	55	254	37	107-150-200-250-300	3,47	SR306CI(CE)254□□□*
341	55	305	37	107-150-200-250-300	3,84	SR306CI(CE)305□□□*
363	55	327	37	107-150-200-250-300	4,01	SR306CI(CE)327□□□*
391	55	355	37	107-150-200-250-300	4,22	SR306CI(CE)355□□□*

*Complete the code by inserting the value of the radius (R): Ex. SR306CI(CE)110 □ □ □ □

R	H	N	M
mm	mm	mm	mm
107	269	205	470
150	355	245	605
200	455	295	760
250	555	345	920
300	655	395	1075



Self-Supporting Capacity Diagram

The maximum length of the self-supporting capacity ($\frac{LS}{2}$) in relationship to the weight of the cables and hoses contained per linear metre.

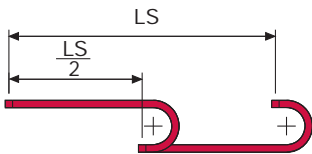
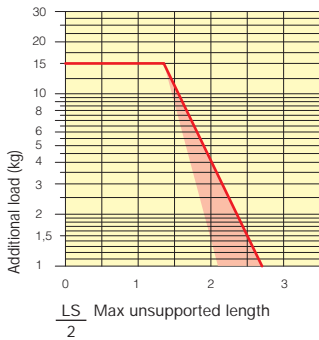

The red marking in the diagram area considers the difference of weight between various widths of chains assembled with nylon frames every second pitch.

For applications with $\frac{LS}{2}$ and weights not included in the area of the diagram showing self-supporting capacity, verify the possible use of support rollers (see page 30).

End Brackets

The end brackets set allows the two ends of the chain to be attached to the equipment.

Nylon Type

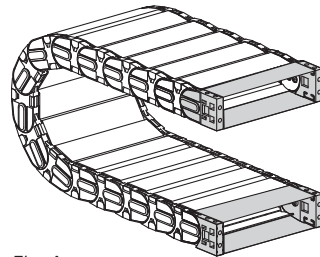

Fig. A
The chain can be fixed frontally, inner or outer radius. (Fig A)

Bright Zinc Plated Steel Type*

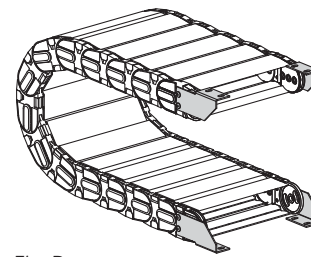
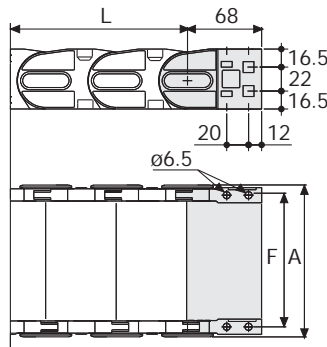

Fig. B
Chain fixed outside the radius. (Fig B)
See end brackets mounting variations page 31.



Chain Type	F mm
SR306CI(CE)043	61
SR306CI(CE)054	72
SR306CI(CE)068	86
SR306CI(CE)074	92
SR306CI(CE)088	106
SR306CI(CE)093	111
SR306CI(CE)100	118
SR306CI(CE)110	128
SR306CI(CE)118	136
SR306CI(CE)129	147
SR306CI(CE)143	161
SR306CI(CE)168	186
SR306CI(CE)193	211
SR306CI(CE)204	222
SR306CI(CE)218	236
SR306CI(CE)245	263
SR306CI(CE)254	272
SR306CI(CE)305	323
SR306CI(CE)327	345
SR306CI(CE)355	373

Nylon Type Part Numbers

Complete Set Assembled Chain Type	End Brackets Set
SR306	AN306C□□□KM

Complete Set Unassembled Chain Type	End Brackets Set
SR306	AN306C□□□K

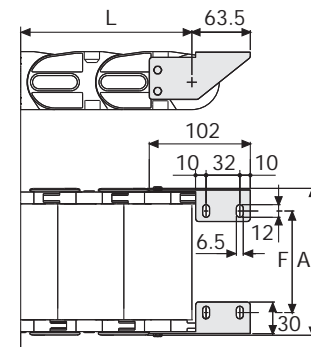

Chain Type	F mm
SR306CI(CE)043	36
SR306CI(CE)054	47
SR306CI(CE)068	61
SR306CI(CE)074	67
SR306CI(CE)088	81
SR306CI(CE)093	86
SR306CI(CE)100	93
SR306CI(CE)110	103
SR306CI(CE)118	111
SR306CI(CE)129	122
SR306CI(CE)143	136
SR306CI(CE)168	161
SR306CI(CE)193	186
SR306CI(CE)204	197
SR306CI(CE)218	211
SR306CI(CE)245	238
SR306CI(CE)254	247
SR306CI(CE)305	298
SR306CI(CE)327	320
SR306CI(CE)355	348

Bright Zinc Plated Steel Type Part Numbers

Complete Set Assembled Chain Type	End Brackets Set
SR306	A306CU□□□KM□**

Complete Set Unassembled Chain Type	End Brackets Set
SR306	A306CU□□□K□**

*Available on request in stainless steel
** 1=Pos.1; 2=Pos.2; 3=Pos.3
See end brackets mounting variations page 31.

Serie Protection

SR306CI SR306CE

Nylon Protection Cable Chain with openable aluminium covers