

Serie Heavy

SR308B

Nylon Cable Chain with un-screwable aluminium rods

Inner height (D) 48 mm
 Strong double share Sideband & Frame construction with large anti-friction triple-pin. Alu-rod frames are un-screwable from inner and outer radius. As standard the chain comes with frames every second link, on request with frames every link. Vertical and horizontal separator systems are available.

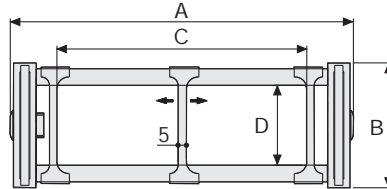

Separator

- Unassembled	Part.no S3000F
- Assembled	Part.no S3000FMC

Pin

Part.no PG308

Technical characteristics when self-supported

Speed	8 m/s
Acceleration	40 m/s ²

For higher requirements please consult our technical dept.

A	B	C	D	R	Weight/m	Chain
mm	mm	mm	mm	mm	kg	Part Number
156	75	100	48	150-180-200-230-280-400	2,85	SR308B100 □*
206	75	150	48	150-180-200-230-280-400	3,00	SR308B150 □*
256	75	200	48	150-180-200-230-280-400	3,15	SR308B200 □*
306	75	250	48	150-180-200-230-280-400	3,30	SR308B250 □*
356	75	300	48	150-180-200-230-280-400	3,45	SR308B300 □*
C+56	75	48	150-180-200-230-280-400		SR308B □□□ □**

*Complete the code by inserting the value of the radius (R): Ex. SR308B200 □

Where: 1=150; 2=180; 3=200; 4=230; 5=280; 6=400

**Complete the code by inserting the value of the quote C and the radius (R): Ex. SR308B □ □ □ □ □

Chain equipped with aluminium rods every pitch: complete the code by inserting the letter D.

Ex. SR308B2001 □

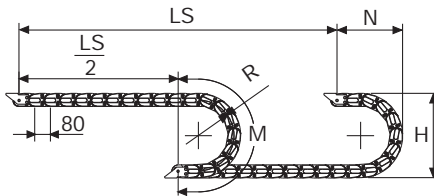

R	H	N	M
mm	mm	mm	mm
150	375	270	635
180	435	300	725
200	475	320	790
230	535	350	885
280	635	400	1040
400	875	520	1420

Length of chain (L)

Half travel distance ($\frac{LS}{2}$)
 plus length of curve (M)

$$L = \frac{LS}{2} + M$$



Self-Supporting Capacity Diagram

The maximum length of the self-supporting capacity ($\frac{LS}{2}$) in relationship to the weight of the cables and hoses contained per linear metre.

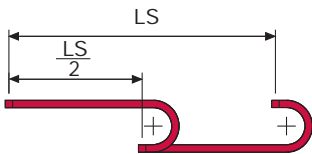
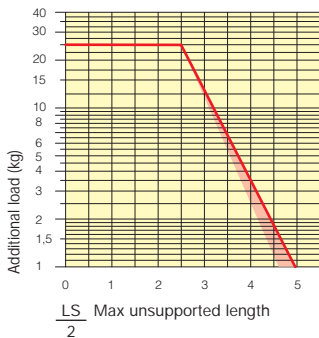

The red marking in the diagram area considers the difference of weight between various widths of chains assembled with rods every second pitch.

For applications with $\frac{LS}{2}$ and weights not included in the area of the diagram showing self-supporting capacity, verify the possible use of support rollers (see page 30).

End Brackets

The end brackets set allows the two ends of the chain to be attached to the equipment.

Nylon Type

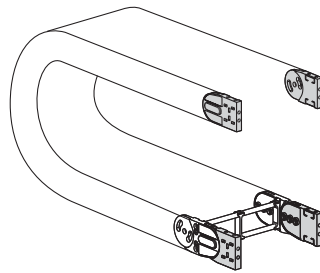

Fig. A
The chain can be fixed frontally, inner or outer radius. (Fig A)

Bright Zinc Plated Steel Type*

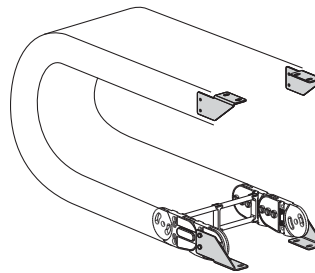
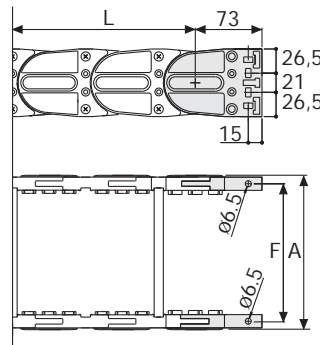
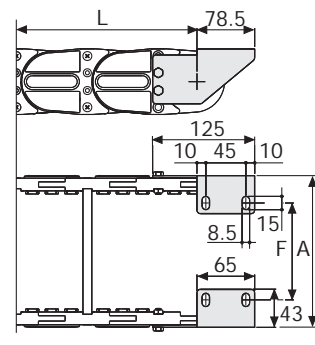

Fig. B
Chain fixed outside the radius. (Fig B)
See end brackets mounting variations page 31.



Chain Type	F mm
SR308B100	135
SR308B150	185
SR308B200	235
SR308B250	285
SR308B300	335
Special dimension F=A-21	



Chain Type	F mm
SR308B100	93
SR308B150	143
SR308B200	193
SR308B250	243
SR308B300	293
Special dimension F=A-63	

Nylon Type Part Numbers

Complete Set Assembled	
Chain Type	End Brackets Set
SR308B...	AN308KM
Complete Set Unassembled	
Chain Type	End Brackets Set
SR308B...	AN308K

Bright Zinc Plated Steel Type Part Numbers

Complete Set Assembled	
Chain Type	End Brackets Set
SR308B...	A308KM □ **
Complete Set Unassembled	
Chain Type	End Brackets Set
SR308B...	A308K □ **

*Available on request in stainless steel
** 1=Pos.1; 2=Pos.2; 3=Pos.3
See end brackets mounting variations page 31.

Serie Heavy

SR308B

Nylon Cable Chain with un-screwable aluminium rods

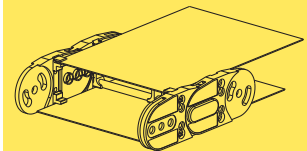

Steel laminar cover.

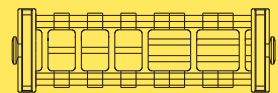

Supplementary movable separators.

Special tool to remove the connecting pivots:
Part Number PZ038.



For further information please consult Brevetti Stendalto's Technical Office