

# Serie Sliding

## SR328SI/SR328SE

### Nylon Sliding Cable Chain with openable frames

Inner height (D) 57 mm  
 Strong double share Sideband & Frame construction with large anti-friction triple-pin. The chain incorporates large sliding-skid surfaces to offer durability, even with high speed/loads. Frames openable from inner radius (..SI) and outer radius (..SE). As standard the chain comes with frames every second link, on request with frames every link. Modular separator systems are available.

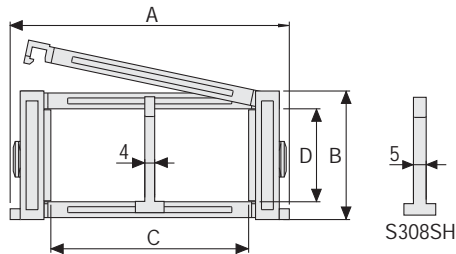

Separator	
- Unassembled	Part.no S308C
- Assembled	Part.no S308CMC
Strong-hold separator for C > 200 mm	
- Unassembled	Part.no S308SHF
- Assembled	Part.no S308SHFMC
Pin	
	Part.no PG328TP

#### Technical characteristics

Speed	3,5 m/s
Acceleration	8 m/s <sup>2</sup>

For higher requirements please consult our technical dept.

A	B	C	D	R	Weight/m	Chain
mm	mm	mm	mm	mm	kg	Part Number
119	79	61	57	150-180-200-230-280-400	2,70	SR328SI(SE)061□□□*
130	79	72	57	150-180-200-230-280-400	2,73	SR328SI(SE)072□□□*
144	79	86	57	150-180-200-230-280-400	2,76	SR328SI(SE)086□□□*
150	79	92	57	150-180-200-230-280-400	2,78	SR328SI(SE)092□□□*
164	79	106	57	150-180-200-230-280-400	2,82	SR328SI(SE)106□□□*
169	79	111	57	150-180-200-230-280-400	2,82	SR328SI(SE)111□□□*
176	79	118	57	150-180-200-230-280-400	2,82	SR328SI(SE)118□□□*
186	79	128	57	150-180-200-230-280-400	2,86	SR328SI(SE)128□□□*
194	79	136	57	150-180-200-230-280-400	2,89	SR328SI(SE)136□□□*
205	79	147	57	150-180-200-230-280-400	2,89	SR328SI(SE)147□□□*
219	79	161	57	150-180-200-230-280-400	2,94	SR328SI(SE)161□□□*
244	79	186	57	150-180-200-230-280-400	3,01	SR328SI(SE)186□□□*
269	79	211	57	150-180-200-230-280-400	3,06	SR328SI(SE)211□□□*
280	79	222	57	150-180-200-230-280-400	3,08	SR328SI(SE)222□□□*
294	79	236	57	150-180-200-230-280-400	3,14	SR328SI(SE)236□□□*
321	79	263	57	150-180-200-230-280-400	3,20	SR328SI(SE)263□□□*
330	79	272	57	150-180-200-230-280-400	3,20	SR328SI(SE)272□□□*
381	79	323	57	150-180-200-230-280-400	3,31	SR328SI(SE)323□□□*
403	79	345	57	150-180-200-230-280-400	3,36	SR328SI(SE)345□□□*
431	79	373	57	150-180-200-230-280-400	3,49	SR328SI(SE)373□□□*

\*Complete the code by inserting the value of the radius (R): Ex. SR328SI(SE)118 □ □ □ □  
 Chain equipped with nylon frame every pitch: complete the code by inserting the letter D.  
 Ex. SR328SI(SE)118150 □

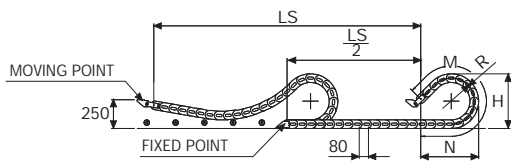

Length of chain (L)  
 Half travel distance ( $\frac{LS}{2}$ )  
 plus length of curve (M)

$$L = \frac{LS}{2} + M$$

R	H	N	M
mm	mm	mm	mm
150	375	425	955
180	435	530	1220
200	475	600	1395
230	535	700	1655
280	635	875	2095
400	875	1285	3145



### End Brackets

The end brackets set allows the two ends of the chain to be attached to the equipment. One set comprises two movable end brackets to install at the moving point and two standard steel end brackets to install at the fixed point.

Bright Zinc Plated Steel Movable Type\* (moving point)      Bright Zinc Plated Steel Type\* (fixed point)

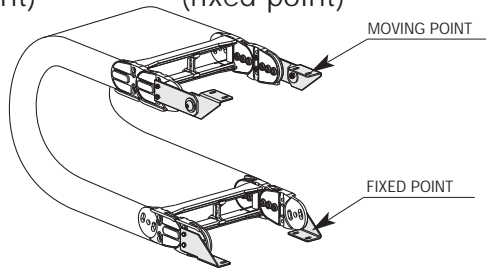
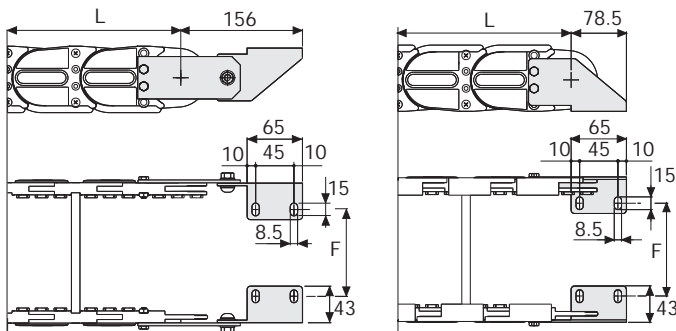

Fig. A  
Chain fixed outside the radius. (Fig A)



Chain Type	F mm
SR328SI(SE)061	44
SR328SI(SE)072	55
SR328SI(SE)086	69
SR328SI(SE)092	75
SR328SI(SE)106	89
SR328SI(SE)111	94
SR328SI(SE)118	101
SR328SI(SE)128	111
SR328SI(SE)136	119
SR328SI(SE)147	130
SR328SI(SE)161	144
SR328SI(SE)186	169
SR328SI(SE)211	194
SR328SI(SE)222	205
SR328SI(SE)236	219
SR328SI(SE)263	246
SR328SI(SE)272	255
SR328SI(SE)323	306
SR328SI(SE)345	328
SR328SI(SE)373	356

### Bright Zinc Plated Steel Type Part Numbers

Complete Set Assembled	
Chain	End Brackets
Type	Set
SR328SI(SE)...	A328KM

Complete Set Unassembled	
Chain	End Brackets
Type	Set
SR328SI(SE)...	A328K

\*Available on request in stainless steel

### Serie Sliding

SR328SI  
SR328SE  
Nylon Sliding Cable Chain  
with openable frames

3

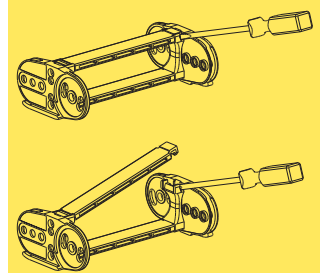

How to open the cover.

Special tool to remove the connecting pivots:  
Part Number PZ038.



For further information please consult Brevetti Stendalto's Technical Office