

WHITEPAPER

SINGLE PAIR ETHERNET

SINGLE PAIR ETHERNET



CONTENTS

1. Single Pair Ethernet (SPE):
The future of IIOT
2. History and motivation of SPE
3. Standardisation: a long way but not
yet completed
4. The benefits of SPE
5. Typical applications for SPE
6. Ethernet Advanced Physical Layer:
SPE for the process industry
7. The SPE ecosystem
8. The role of LAPP
9. Fit for SPE?

1. SINGLE PAIR ETHERNET (SPE): THE FUTURE OF IIOT

Plants, machines, controls, actuators, sensors and even tools and workpieces: in the factory of the future, everything is connected to everything – including the Internet and the cloud – every physical object has a virtual image.

So far, though, the Industrial Internet of Things has experienced a system discontinuity: while Ethernet has long been established as the communication standard at the control level of the automation pyramid, other standards dominate at the lower level, the field level. Fieldbus systems prevail where sensors and actuators are networked. Some components often still transmit information in analogue mode. But if the promises of Industry 4.0 become reality, seamless communication across all levels is essential – the field level cannot remain an island of technology. This requires new infrastructure at field level. It must meet several prerequisites: it must be compatible with the Ethernet networks above it. At the same time, it should be cost-effective and space-saving, as space is tight in many machines.

Industry has created a new standard for this: Single Pair Ethernet (SPE). SPE cables only have one twisted pair; Ethernet cables normally have two or even four pairs of wires. This enables SPE to square the circle: it is almost as powerful as Multi Pair Ethernet, but it allows much larger distances, is more compact and requires less installation effort. SPE makes the field level smart and ensures consistent, reliable global networking. Manufacturers and users agree that **Single Pair Ethernet is the future of the Industrial Internet of Things (IIOT).**

This has numerous advantages for users, but some aspects have to be taken into consideration now. Standardisation for SPE is well advanced and the first products are on the market. Hence, it is highly advisable for companies to involve SPE in their planning already. This whitepaper explains which aspects are important and what users need to pay attention to.

2. HISTORY AND MOTIVATION OF SPE

The origins of Ethernet go back to the 1970s. It was originally developed for fast communication between office computers and data centres, efforts have been made for around 20 years to establish Ethernet in industrial production too. This has many advantages:

- **IT data and real-time data are transferred via the same network**
- **Cascading of switches enables extensive network expansions**
- **Large amounts of data can be transferred at high speed**
- **All network participants have equal access to buses**
- **The number of participants is almost unlimited due to the wide address range**
- **Different transmission media can be combined (cable, wireless, fibre optic cable)**

Industrial Ethernet has thus seen a very high growth rate in recent years, considerably higher than the growth rates of fieldbuses. Industrial Ethernet will be the dominant technology for networking in industry in a few years. However, this is not yet the case at the lower level, as fieldbus systems still dominate there – despite the many advantages of Industrial Ethernet. With Industry 4.0 and the smart factory, this system discontinuity can no longer be maintained. They require consistent networking of the three levels of the automation pyramid (some definitions also refer to five levels) using a uniform standard with the TCP/IP protocol.

Help is at hand, though, thanks to the automotive industry. Since 2015, they have been considering developing a space-saving successor to the CAN bus to transmit larger data volumes in the vehicle. Back then, the first standards were defined for cables that only used one core pair instead of the four pairs common to Ethernet. Later on, others were added for data rates of up to 1 Gbit/s, which is also suitable for semi-autonomous driving. Even faster standards of up to 10 Gbit/s for autonomous driving are planned.

The answer for both the automotive industry’s requirements for fast data transmission in vehicles and the manufacturing industry’s demand for seamless networking in factories is one and the same: Single Pair Ethernet, a transmission standard that can only be used with one core pair in a cable. SPE has numerous advantages:

- **Networking with TCP/IP without system disruptions**
- **Every field participant can be addressed via IP**
- **Suitable for real-time critical applications thanks to TSN (Time-Sensitive Networking)**
- **Substitute for the proliferation of proprietary fieldbuses**
- **Large distances up to 1,000 meters**
- **This enables more flexibility in cabling and does not use gateways with SPE**
- **Power supply to terminal devices via the same cable via PoDL**
- **Sustainable thanks to the omission of batteries, compared to wireless technologies**
- **Less material and weight**
- **Flexible and space-saving, e.g. in drag chains**
- **Easier and error-free installation, saving assembly time**
- **Higher operational reliability than wireless technologies**
- **More economical**

Since then, numerous electrical connection companies, such as cable and connector manufacturers, have joined forces in several partner networks to advance the technology. The members of the consortium expect SPE to replace the prevailing fieldbus systems today at sensor/actuator level in the coming years, thus becoming the basic infrastructure for intelligent sensors and actuators and the smart factory.

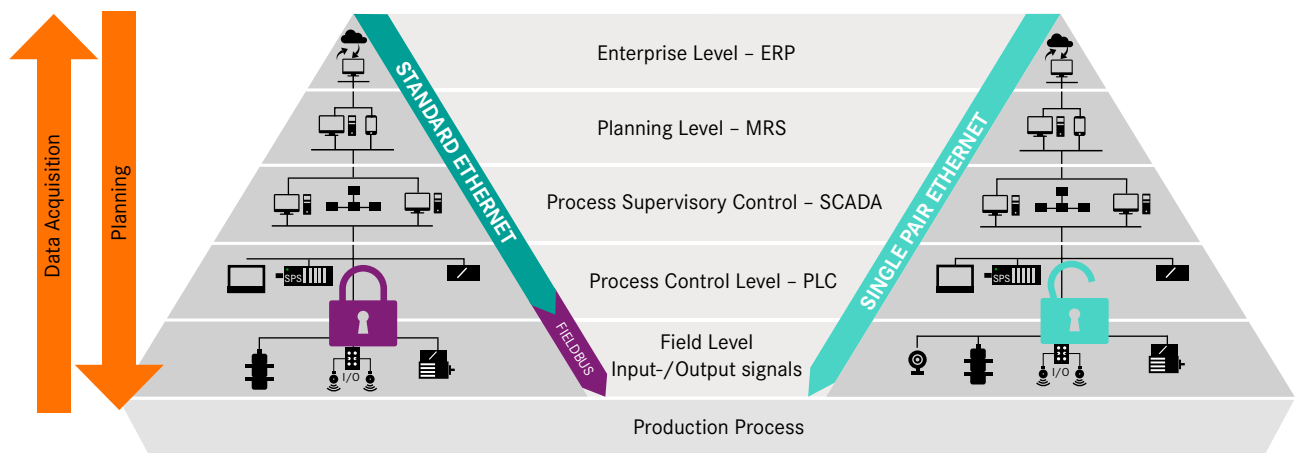

Figure: The change in the industrial network due to Single Pair Ethernet

3. STANDARDISATION: A LONG WAY BUT NOT YET COMPLETED

For a technology to establish itself widely on the market, standards are required. As a result, the customer can rely on all components working together, regardless of the manufacturer they come from. With fieldbuses, this is usually only the case within one system.

There are more than a dozen different systems which are not automatically compatible. The members of the SPE Industrial Partner Network agree that this should not happen with SPE. Consequently, they are currently working on system and component standardisation. While standardisation has been completed for the system properties, consultations are still under way about the components, particularly the connectors.

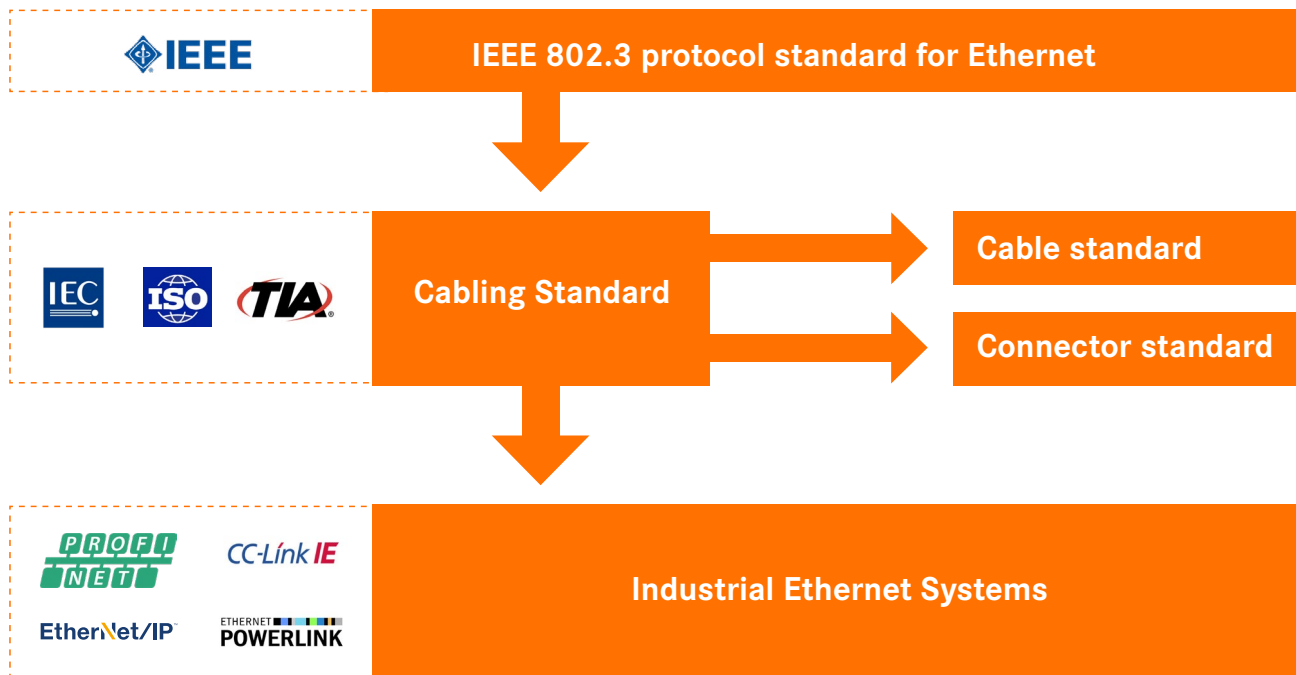

Figure: Overview of standardisation process for Single Pair Ethernet

3.1. PROTOCOL STANDARDS AT IEEE

Essentially four performance classes with different data rates and link length (total cable length between two active devices including a maximum of four connectors) have been defined. In terms of the link lengths, a distinction is made between unshielded and shielded cables. The shielded cables are predominantly relevant for industrial applications as they provide longer cable lengths and the necessary protection against electromagnetic interference:

- 10 Mbit/s up to 1,000 m
- 100 Mbit/s up to 40 m
- 1 Gbit/s up to 40 m
- 2.5 to 10 Gbit/s up to 15 m

Multidrop is also possible. IEEE 802.3cg allows up to eight branches of the master cable. This interesting feature enables a network participant to be connected via a direct physical branch without a switch.

The IEEE 802.3cg standard is noteworthy. For the first time, it is possible to bridge distances of more than 100 meters using Ethernet. The IEEE 802.3bu PoDL standard is not listed in the table. The abbreviation stands for Power over Dataline, i.e. the transmission of electrical power via SPE – more information below.

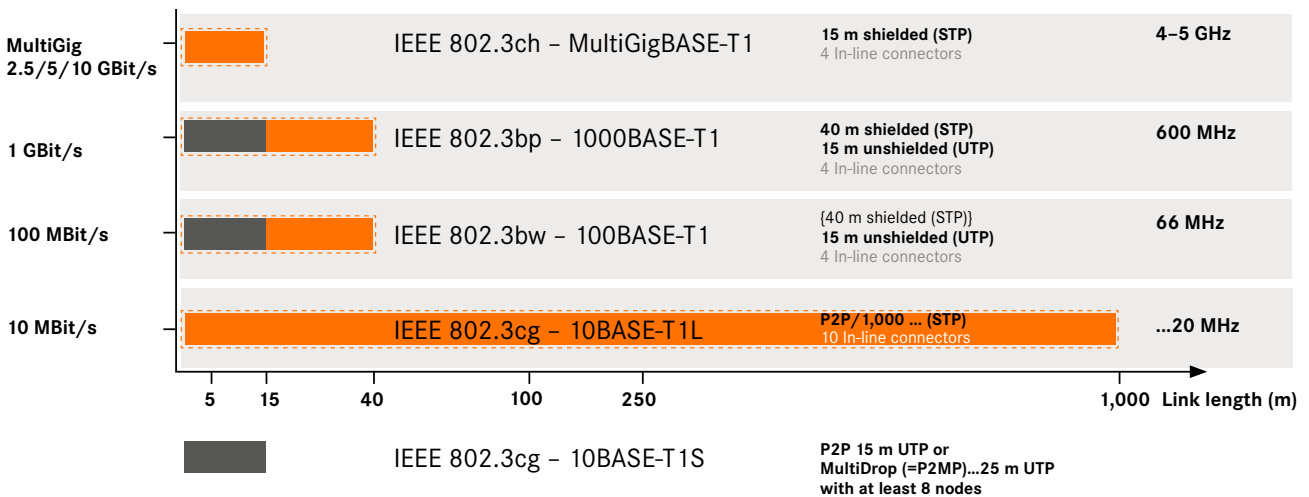

Figure: Overview of the IEEE protocol standards for Single Pair Ethernet

3.2. ISO AND TIA CABLING STANDARDS

The ISO/IEC 11801 series of standards plays an important role in setting up Ethernet networks. This standard defines complete cabling ducts with all the necessary parameters (length, number of connections, bandwidth and the complete set of transmission parameters including NEXT, FEXT, shielding properties, etc.) in relation to the surrounding environment. This is required in particular for network planning, as well as for the metric testing of the installed cabling.

3.3. STANDARDISATION OF SPE COMPONENTS (CABLES AND CONNECTORS) AT IEC

3.3.1 Cables for SPE

Standardisation has largely been completed for the cables. The IEEE standard 802.3 defines the protocol standards from which the International Electrotechnical Commission (IEC) has defined the design and electrical properties of SPE cables in its series of standards IEC 61156. The IEC 61156 standard divides Single Pair Ethernet cables according to installation type, maximum link length and data transmission rate.

The colour of the cores is always the same: blue for BI_DA+ and white for BI_DA-. IEC 61156-11 (fixed installation) and IEC 61156-12 (flexible application) define the properties for a transmission rate of 1 Gbit/s over a transmission distance of 40 m. To achieve the high transmission rate via just one core pair, the standard sets particularly high requirements for the electrical properties. This requires a significantly higher bandwidth than conventional Industrial Ethernet Cat.5e data cables, which is why they are specified for a frequency of up to 600 MHz. IEC 61156-13 (fixed installation) and IEC 61156-14 (flexible application) are currently being developed for longer distances up to 1,000 m; the data rate here is 10 Mbit/s.

The standards also define the cross-sections of the conductors. They range from 16 AWG and 18 AWG (approx. 2 mm core diameter) to 22 AWG (approx. 1.6 mm diameter) to 26 AWG (approx. 1 mm diameter). The slightly thicker 22 AWG, which also have a particularly low attenuation, are suitable for PoDL. 26 AWG is intended for particularly thin cables. This reduces the diameter by a quarter compared to a four-pair cable and reduces the weight by half – ideal for tight construction spaces, such as in a control cabinet.



INFO

The ANSI/TIA standards are of great importance for the markets in the USA, Canada and Mexico. SPE is included in the TIA 42 papers via the addendum TIA-1005-A-3.

Cross Section	Wire Diameter	Cable Diameter
26 AWG	1.0–1.3 mm	4–5 mm
22 AWG	1.5–2.0 mm	5–6 mm
18 AWG	2.35–2.7 mm	6.5–8 mm
16 AWG	3.0–3.4 mm	8–10 mm

Figure: Cable dimensions depending on core cross-section

Cross Section	Data rate	Applications	IEC Standard
26 AWG	1Gbit/s 1000BASE-T1 up to 40m	Fixed installation	IEC 61156-11
		Flexible installation	IEC 61156-11
		Continuous flexing installation (e. g. cable chain)	IEC 61156-12
		Robotic	IEC 61156-12
22 AWG	1 Gbit/s 1000BASE-T1 up to 40m (optimized for PoDL)	Fixed installation	IEC 61156-11
		Flexible installation	IEC 61156-11
		Continuous flexing installation (e. g. cable chain)	IEC 61156-12
		Robotic	IEC 61156-12
18 AWG	10 Mbit/s 10BASE-T1 up to 1,000m	Fixed installation	IEC 61156-13
		Flexible installation	IEC 61156-14

Figure: SPE cables for different applications and installation types according to IEC 61156

3.3.2. Cables for specific applications

When selecting the right cables for the respective application, the electrical transmission parameters and cable design described by the standards are not the only relevant aspects. Particular attention must be paid to environmental conditions or fire protection in industrial use.

With regard to environmental conditions, it must be borne in mind that cables can come into contact, with media or be exposed to high temperatures or UV light. This has an impact on the selection of the correct outer jacket material. PVC (polyvinyl chloride) is a cost-effective all-rounder with good to very good flame retardance. PUR (polyurethane) is highly resistant to mechanical stresses. Special materials such as the ROBUST sheath material from LAPP are highly resistant to chemical influences and are ideally suited to food processing, for example.

The numerous application-specific requirements show that there will also be many different specialised cables for Single Pair Ethernet.



INFO

When it comes to fire properties, approvals such as UL for the North American market or CPR (Construction Product Regulation) for the European Economic Area are also added as a selection criterion.

3.3.3 Connectors for SPE

SPE connectors are standardised in the IEC 63171 standard.

Six different connector faces have been introduced into the standard. From a user perspective, a standardisation is desirable to reduce the variety of components and avoid incompatibilities. Ultimately, the market will decide which standard will prevail. What matters here will be the interface implemented by the majority of device manufacturers and preferred by the user.

Standard	Description	Submitted by	MICE Environment
IEC 63171	Basis Standard		M ₁ I ₁ C ₁ E ₁ ... M ₃ I ₃ C ₃ E ₃
IEC 63171-1	„LC Style“ IP20 environment	CommScope	M ₁ I ₁ C ₁ E ₁
IEC 63171-2	„Type 2 Style“ IP20 environment	PxC/Weidmüller	M ₁ I ₁ C ₁ E ₁
IEC 63171-3	„Tera Style“ IP20 environment	Siemon	M ₁ I ₁ C ₁ E ₁
IEC 63171-4	„BKS Style“ IP20 environment	BKS	M ₁ I ₁ C ₁ E ₁
IEC 63171-5	„Type 5 Style“ IP65/67 environment	PxC/Weidmüller	M ₂ I ₂ C ₂ E ₂ M ₃ I ₃ C ₃ E ₃
IEC 63171-6	„Industrial Style“ IP20 and IP65/67 environment	SPE Industrial Partner Network	M ₁ I ₁ C ₁ E ₁ M ₂ I ₂ C ₂ E ₂ M ₃ I ₃ C ₃ E ₃

Figure: The six Single Pair Ethernet plug types according to IEC 63171

The IEC 63171-6 standard, which is promoted by the SPE Industrial Partner Network, has the greatest support. It describes six different housing shapes based on a uniform connector face: five IP67 connectors with M8 or M12 connector/screw connections and an IP20 blade connector. The rectangular connector face with the two pins at 2.8 mm spacing is the same for all of them. The advantage of this is that the plug block with the two connection pins can be combined virtually any number of M8 and M12 circular connectors with screw, push-pull and snap-in plugs. It even fits into future hybrid plugs. This means that an IP20 plug fits easily into IP65/67 sockets with diameters M8 and M12. This is practical if the fitter wants to quickly test a cabling or configure a device with an M12 socket but only has one patch cable with an IP20 plug at hand.



Figure: Example of a connector face according to IEC 63171-6

Further advantages are the symmetry of the connector face and hence the exact same running time of the signals via the two conductors, which is a basic prerequisite for a high transmission quality up to bandwidths of 4 GHz with Ethernet. The symmetrical connector face enables equally symmetrical contact on the PCB. Other positive properties include the high dielectric strength of 1,000 volts (pin to pin) or 2,250 volts (pin to housing), currents of up to 4 A (at 60 °C), more than 1,000 connected cycles (for the IP20 version), confusion-proof polarity and high robustness in terms of temperature, humidity and dust, shock, vibration and electromagnetic compatibility. Last but not least all IEC 63171-6 plugs are suitable for all cable thicknesses with cores from 26 AWG to 18 AWG.

Among other things, the IEC 63171-2 connector, which is supported by the Single Pair Ethernet Alliance, is still in the race. With the connector face represented by the SPE System Alliance, the pins lie on top of one another, which ensures lower space consumption on the circuit, but also increases the dimensions. The different lengths of the PINs, result in asymmetry. These differences in length can be compensated for using additional conductor tracks on the circuit board, which in turn takes up space. The connector face of IEC 63171-2 is asymmetrically wedge-shaped - the pins are thus at different distances from the shield housing. At very high frequencies, the aforementioned asymmetries generate errors. The SPE Industrial Partner Network expects IEC 63171-6 to get the upper hand.

As the system properties for data transmission are standardised, it is generally possible to mix different connectors, i.e. to assemble an IEC 63171-6 plug at one end of the cable and an IEC 63171-2 plug at the other end, provided that the socket needs to be replaced at the switch, for example. A possible way to solve

the problem of incompatible connectors, but not the ideal way. This is the reason why the SPE Industrial Partner Network works to ensure that all market players agree on a plug standard for the benefit of the user.

4. THE BENEFITS OF SPE

Single Pair Ethernet is a real game changer in industrial networking. SPE facilitates networking of sensors and actuators at field level. The thinner cables save space and can also be installed in narrower bending radii.

As the number of components that are networked at field level is increasing rapidly, assembly times are becoming increasingly important for users. As the fitter only has to connect two cores instead of eight in SPE, they can thus save more than half of their working time and noticeably reduce their labour costs. The time required for commissioning machines and systems can also be reduced, as fewer problems arise due to connection errors or poor contact. At the previous system boundaries between the control and control level and the field level, transponders and gateways are now used, establishing a connection to the field level. With SPE, these are eliminated, as it supplies a wide range of field components in a space-saving and cost-effective manner. SPE also requires fewer passive components for the Ethernet interface, which reduces the area on the PCB of the devices to just a quarter. Future switches will thus become much more compact, which saves space on the machine and in the control cabinet and ultimately makes production facilities leaner.

A major advantage of SPE is the longer cable length of up to 1,000 meters. This is ten times the distance that previous Ethernet cables can bridge. This makes Industrial Ethernet also interesting for companies that operate extensive systems, for example in the chemical industry, where a single process line can cover several football pitches. In the past, sensors or actuators were connected there via slow analogue cables or wireless, which mean that the range and the interference immunity are limited. In addition, wireless still requires a cable for the power supply. SPE combines everything in one: high reliability of connection and speed over long distances. At the same time, PoDL (Power over Dataline) ensures the power supply via the same cable.

According to the IEEE 802.3bu PoDL standard, an SPE cable can transmit power of up to 50 watts at 48 volts via a twisted core pair. This offers great advantages, especially at the machine level. An increasing number of sensors, small actuators and IP cameras that require a power supply are being used here. In production, where maintenance cycles need to be long, batteries are not an option,



BENEFITS

- Networking with TCP/IP without system disruptions
- Every field participant can be addressed via IP
- Suitable for real-time critical applications thanks to TSN (Time-Sensitive Networking)
- Substitute for the proliferation of proprietary fieldbuses
- Large distances up to 1.000 meters
- This enables more flexibility in cabling and does not use gateways with SPE
- Power supply to terminal devices via the same cable via PoDL

which means that many components in addition to the data cable require another cable for the power supply. With PoDL, this is no longer necessary in many cases, which halves the cabling effort and reduces problems with tight installation spaces. The current is fed from the switch or from a power supply unit that is inserted into the cable. PoDL is possible for cables from 10 Mbit/s to 10 Gbit/s, with the maximum cable length of up to 1,000 meters. For higher outputs up to 400 watts, hybrid cables containing two additional cores in one sheath are possible. In contrast to Power over Ethernet, PoDL also defines typical on-board mains voltages of 12 and 24 volts for use in vehicles.

Recently, there has been much talk about wireless technologies in connection with factories, particularly 5G. Wireless technologies do have advantages when it comes to data communication in smart factories, especially where frequently changing and mobile systems are used and where larger distances need to be bridged. However, wireless technologies also have disadvantages: they do not transmit electrical energy, meaning that cables are still required for the power supply and in densely packed systems there are wireless shadows with no reception. SPE does not face these limitations. The thin cables go into gaps that are still tight and immediately supply power.

With a cable length of 1,000 meters, SPE is also a cable-based alternative for long-distance wireless communication. The user can be sure that all data will always arrive there in full, no matter what disruptions there are. SPE opens up new possibilities for copper cable. It competes with wireless standards and glass fiber, which is now used to bridge longer distances.

However, it is also clear that SPE is not the solution for everything, and it will not make the established standards for industrial Ethernet with four pairs superfluous. They still have a role to play in the control level of the automation pyramid, where high data transmission rates and plug-in compatibility with office IT are vital. "One size fits all" won't work here either. SPE cannot be connected to devices with a conventional Ethernet interface such as PCs or servers. Power over Ethernet in multi-pair Ethernet cables with 95 watts also allows slightly higher performance than the 50 watts for SPE. There is also the advantage of multi-pair cables being automated. This enables two interconnected Ethernet network ports to negotiate the maximum transmission speed independently. This is currently only possible with SPE if all the chips are from the same manufacturer. User-friendly standardisation is already planned, and this will then make this function available across all manufacturers.



BENEFITS

- Sustainable thanks to the omission of batteries, compared to wireless technologies
- Less material and weight
- Flexible and space-saving, e.g. in drag chains
- Easier and error-free installation, saving assembly time
- Higher operational reliability than wireless technologies
- More economical

5. TYPICAL APPLICATIONS FOR SPE

Industry

SPE enables a factory to be networked across the entire automation pyramid, from the sensor to the management level and the cloud – all using the same technology and in a particularly economical manner. This is in line with the trend towards downsizing, as an increasing number of sensors need to be economically connected. SPE fills the gap between the sensor and actuator. Direct network integration means that sensors and actuators can also become “smarter”, i.e. they can provide additional information or can be conveniently parameterized and diagnosed remotely. Another sensible application in industry is the networking of devices in control cabinets, where thinner cables and smaller connectors can be used to save space.

Bus and rail

In public transport, SPE is suitable for networking information systems, for example for displaying stops or reserving seats, for cameras for monitoring purposes or passenger counting, as well as for infotainment and WiFi.

Electromobility

In battery-electric vehicles, SPE offers a more compact design with lower bending radii and also more flexibility.

SPE also saves weight: a standard four pair cable is considerably heavier than a single pair SPE cable.

Building automation

In buildings, SPE can network sensors, for example in fire alarm systems, light or temperature sensors, as well as access control systems, information boards, e.g. for space assignment and much more. Smart lighting would also benefit from the reduced installation outlay.

Retail

In supermarkets, in outlets with quickly perishable goods, sensors can transmit information about the outlets' inventory level via SPE.

The following table shows some applications for which SPE is particularly suitable, but also applications where four-pair Ethernet is still viable.

Application	Cable Type	Data rate	Protocol
Passenger Counter	SPE	10 Mbit/s	10BASE-T1S (MD) OR 100BASE-T1
Door Monitoring and Control	SPE	10 Mbit/s	10BASE-T1S (MD)
IP Speaker	SPE	10 Mbit/s	10BASE-T1S (MD)
SOS Terminal	SPE	10 Mbit/s	10BASE-T1S (MD)
Display	SPE	100 Mbit/s	100BASE-T1
Driver assistance terminal	SPE	1 Gbit/s	1000BASE-T1
IP-Cameras (indoor/outdoor)	SPE	100 Mbit/s	100BASE-T1
GSM-/WiFi Router and access	4 pair	1 Gbit/s	1000BASE-T1
Door opener	SPE	10 Mbit/s	10BASE-T1S (MD)
Ticket vending machine	SPE	10 Mbit/s	10BASE-T1S (MD)

Figure: Application examples for different SPE protocols



SIDE NOTE

Side note: 1 MPE = 4 SPE?

The idea is obvious: if Single Pair Ethernet requires one core pair but previous Ethernet cables have four pairs, then could four SPE core pairs be combined in one cable? Although cable sharing is possible in principle, it is not feasible from a technical and economic perspective. In terms of transmission speed, there would be no gain, as four SPE cables together achieve 4 Gbit/s, while a standard Cat.6_A cable achieves 10 Gbit/s. And instead of 100 meters, the range would be reduced to 40 meters. To be able to use the four core pairs for SPE at all, the user would have to check every cable for its suitability, as SPE requires a bandwidth of 600 MHz.

6. ETHERNET ADVANCED PHYSICAL LAYER: SPE FOR THE PROCESS INDUSTRY

For long distances in large plants such as in the chemical industry, in refineries or in food processing, Ethernet APL is a game-changer. Single Pair Ethernet enables a consistent and uniform Ethernet connection right up to the field level. However, SPE cannot be used in potentially explosive areas of the process industry. This is now changing with Ethernet Advanced Physical Layer. Ethernet APL based on 10BASE-T1L meets additional precautions according to IEEE 802.3cg. For example, intrinsic safety is taken into account in Ethernet-APL, which allows it to be used in potentially explosive atmospheres.

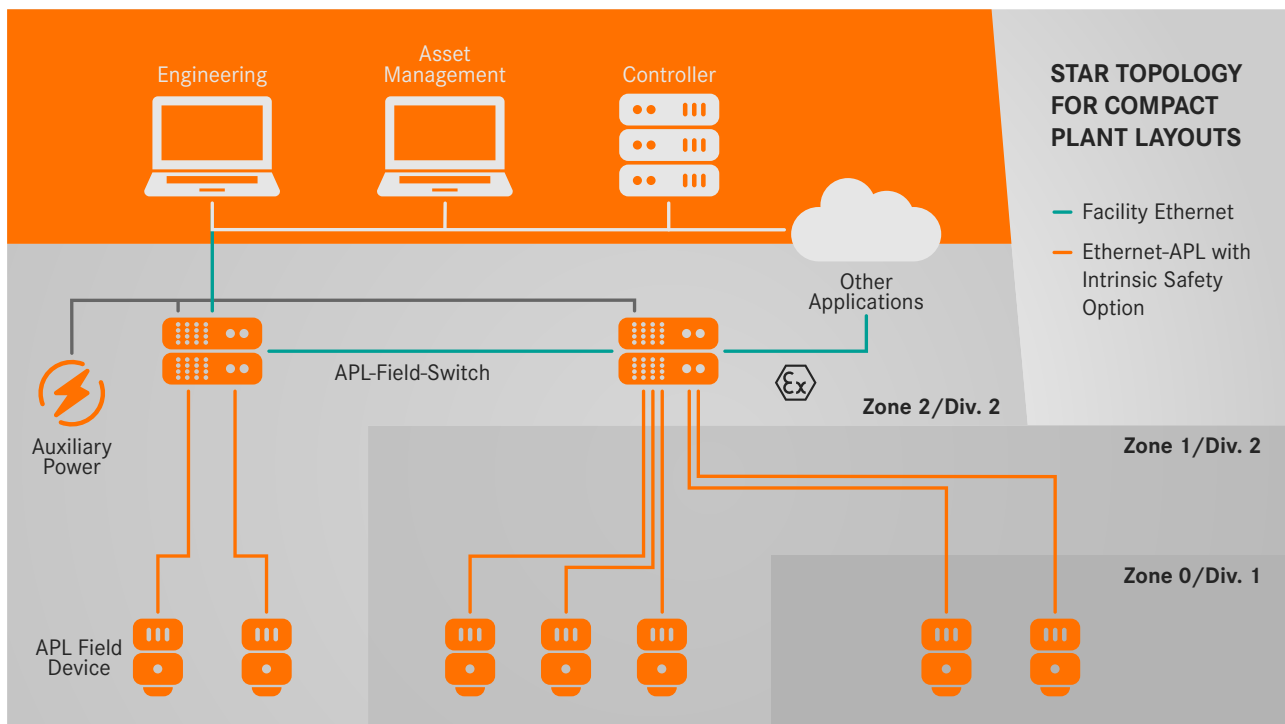

Figure: Use of APL cables

The benefits of Ethernet-APL

Ethernet APL adds important properties to the physical layer of Ethernet:

- Intrinsic safety for areas at risk of explosion
- Distances up to 1,000 metres
- Two-way communication up to 10 Mbit/s
- Real time capability
- Integrated power supply
- Future-proof thanks to IEEE standard
- Easy integration into the process control system
- Easy installation and commissioning
- Remote access for fast device configuration

For users, this has numerous advantages:

- Ethernet APL makes slow and analogue data communication at field level digital and future-proof.
- With cable lengths of up to 1,000 metres, very large plants can be networked with high-performance data transmission.
- It enables new, data-based business models in the process industry.
- Areas at risk of explosion can become part of smart production.
- Uniform Ethernet technology across the entire automation pyramid saves users time and money.
- LAPP offers an extensive portfolio for SPE and Ethernet APL.

Are you interested in Ethernet APL? **You can find further information here.**

7. THE SPE ECOSYSTEM

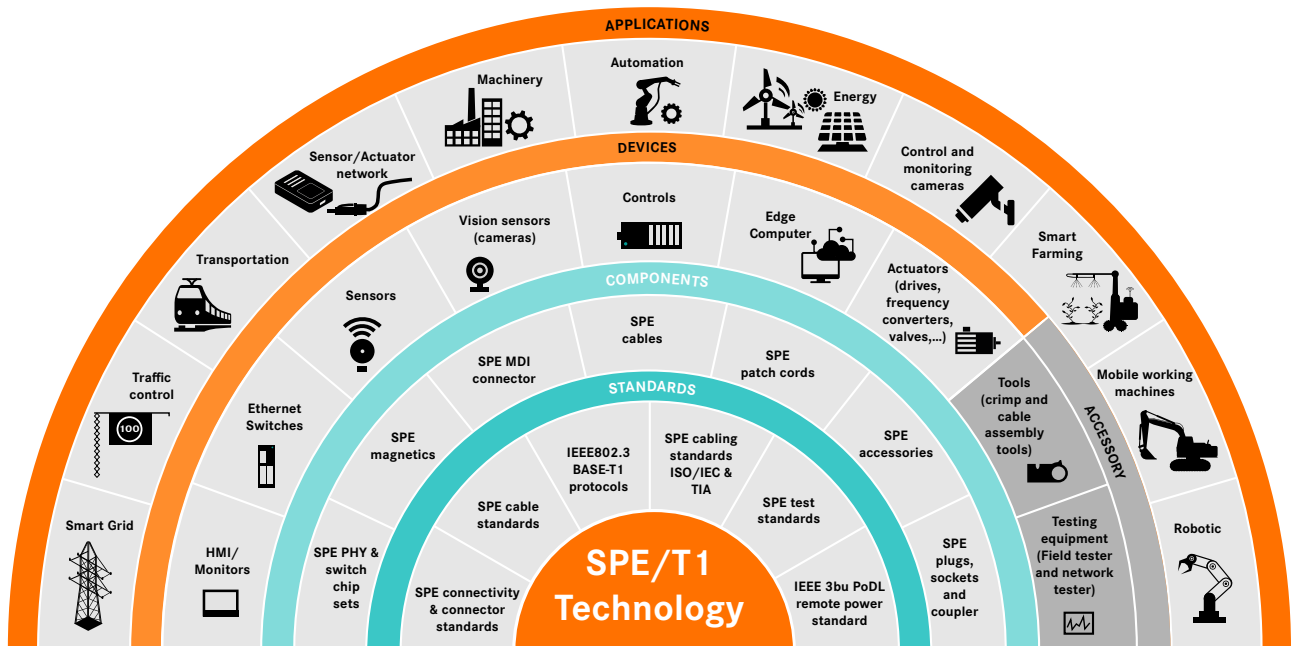

Figure: SPE ecosystem

The graphic suggests that Single Pair Ethernet is not just one of many new standards for data cables, but a complete ecosystem of components for seamless networking in industry at field level. In addition to cables and plugs, this includes new patch cables and switches, as well as numerous components from the application such as sensors, actuators and cameras. New semiconductor chips for the physical interface between electronics and cables, chips for switches, controllers for PoDL and passive components such as magnetic transformers are under development.

In addition to the standardised cable types, special versions are currently under development for various mechanical stresses such as torsion, highly flexible for

drag chains or robot applications. The cables must also withstand extreme environmental conditions such as heat or cold, or be resistant to aggressive media such as oils and acids. UL approval is an important characteristic for North America for customers which sell their systems worldwide. Different hybrid cables combining SPE with additional elements round off the selection.

8. THE ROLE OF LAPP

LAPP creates connections – globally, reliably and tailor-made. This also applies to SPE. LAPP began developing industrial SPE cables early on and can already offer them. Standards are important for further proliferation. That is why LAPP is committed to standardisation in conjunction with many other manufacturers of connection technology. The Single Pair Ethernet technology is already internationally standardised, providing the basis for global expansion. However, several proposals have been made for industrial connectors in the IEC 63171 standard, which means that users would have to deal with multiple plugs if several standards were to take root. For connectors, LAPP favours the connector face in accordance with IEC 63171-6 and plays an active role in disseminating this







	Product	Outer jacket	Insert	Data rate	Length max.	Diameter
Cables	 ETHERLINE® T1 FD P 1x2x26/19AWG	PUR	Drag chain	Up to 100 Mbit/s	15 m	4,6 mm
	 ETHERLINE® T1 PN FLEX T Y 1x2x22/7AWG	PVC	Flexible	10 Mbit/s – 1 Gbit/s	40 m	5,8 mm
	 ETHERLINE® T1 PN FLEX Y 1x2x22/7AWG	PVC	Flexible	10 Mbit/s – 1 Gbit/s	40 m	5,5 mm
	 ETHERLINE® T1 FLEX Y 1x2x26/7AWG	PVC	Flexible	100 Mbit/s – 1 Gbit/s	15 m	4,6 mm
Patchcords	 EPIC® DATA SPE-6 PC M-M CT001	PVC	Flexible	100 Mbit/s – 1 Gbit/s	Various lengths available	5,8 mm
SPE APL cables for hazardous environments	 ETHERLINE® T1L FC Y 1x2x18/1AWG	PVC	Fixed	Up to 10 Mbit/s	Max. 1000 m	8,0 mm
	 ETHERLINE® T1 L FLEX FC Y 1x2x18/7AWG	PVC	Flexible	Up to 10 Mbit/s	Max. 1000 m	8,0 mm

Figure: Industrial SPE cables from LAPP

standard by collaborating with the SPE Industrial Partner Network. LAPP therefore contributes to making quick decision by the market.

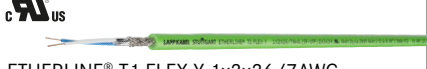
For a user to use SPE, they need the complete infrastructure. In addition to SPE-capable cables and plugs, these are the switches and terminal devices in particular. Not all components are currently available on the market. LAPP is also working on this and will be one of the first manufacturers to offer such components. For users to plan and check a SPE network, they need planning and installation guidelines for the respective uses. These guidelines are developed for industrial Ethernet systems by user organisations such as PI for PROFINET or ODVA for ETHERNET/IP. LAPP is already working on this in working groups with other member companies.

9. FIT FOR SPE?

Users should bear the following in mind when deploying SPE:

1. Users should already look at the new technology, identify potential fields of application and discuss these requirements with manufacturers such as LAPP system decisions are being made now and we manufacturers need the customers' requirements for system design.
2. Take advantage of the opportunities to develop technological knowledge. Manufacturers and the SPE Industrial Partner Network already offer extensive information material such as webinars or e-learning. SPE technology is currently developing very rapidly – we should stay ahead of this industry trend.
3. “Think outside the box” – the new technology offers unimaginable opportunities. Things that previously seemed unthinkable are now possible. SPE is not just about reducing it to two conductions, but also about potential new network structures: trunk capability, Power over Data Line or longer cable lengths are just a few examples. Anyone who stays abreast of these new possibilities and deploys them in their application can benefit from them as much as possible.
4. There's no need to implement every installation in a single pair, just because this is possible. This is why we need to keep the entire Ethernet network in mind in production. While there are numerous cost savings involved with SPE, in many cases it is still beneficial to rely on 4 pair Ethernet cables for installation to avoid any potential system operational issues. Users should remember that standard Ethernet devices must still be able to connect in the event of future plant expansion.



LINKS

News about SPE from LAPP: <https://www.lappkabel.com/industries/industrial-communication/ethernet/single-pair-ethernet.html>



www.single-pair-ethernet.com/en



<https://lappconnect.lappgroup.com/en/expertise/single-pair-ethernet-the-new-improved-fieldbus/>



Follow LAPP on:



You can find our terms of trade at www.lapp.com/en/de/e/000010

To contact your local LAPP representative, please visit www.lapp.com/en/de/

