

CHARGING CABLE

MODE 3, 32A 3-phase, 7m

FOR CHARGING ELECTRIC AND HYBRID CARS



>> THE CHARGING CABLE FROM LAPP with 7m extension length allows easy and fast charging at public charging stations and wall boxes. Three-phase charging up to 22 kW significantly reduces the charging time for electric cars. Thanks to the standardised Type 2 connector, this is possible throughout Europe. The robust design and the silver-plated corrosion resistant contacts ensure optimum power transmission and give the charging cable a long service life.

ADVANTAGES AT A GLANCE

- Up to three times faster charging than with a standard charging cable
- Ergonomic solid rubberised connector/coupling design
- Silver-plated contacts for optimum power transmission and longevity
- Complies with all relevant VDE and IEC product requirements
- Robust design

INCLUDED IN DELIVERY

- Charging cable for public charging stations and wall boxes, 3-phase
- Operating instructions

TECHNICAL INFORMATION

- Type 2 connector design in compliance with IEC standard makes the charging cable usable throughout Europe
- Transmission of charging currents up to 32A per phase. As a result, 1-phase charging procedures up to 7.4 kW or 3-phase up to max. 22 kW are possible (depending on vehicle)

TECHNICAL DATA

- Connections: Type 2 on both sides
- Charging mode: Mode 3
- Length: 7.0 metres
- Standard protection class IP44, tested for IP67 (Heavy Duty line)
- Halogen-free
- Flame-retardant
- Oil-resistant
- Temperature resistant: -30°C to +50°C
- Maximum charging capacity: 22 kW

DATA SHEET CHARGING CABLE

ITEM NO.: 5555931018

TYPE: CHARGING CABLE CHARGE M3 T2P/T2C S 32A 3P 7000

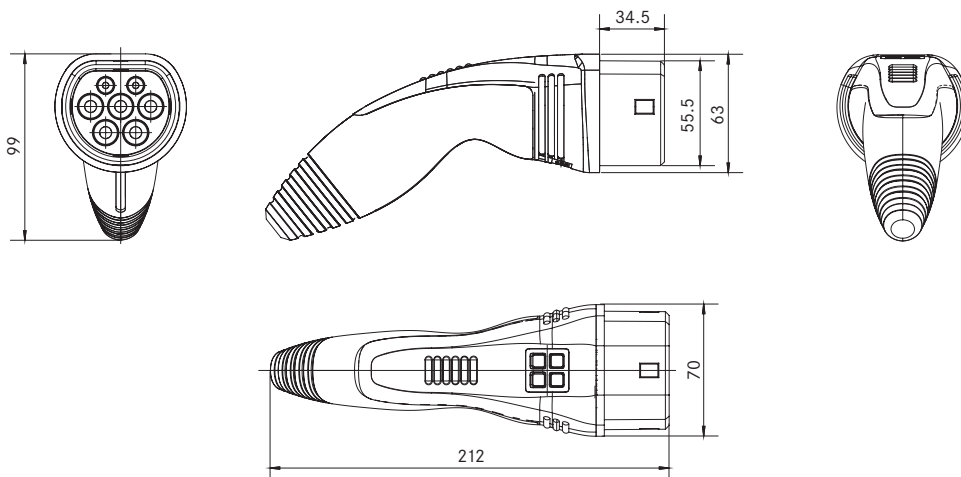

Cable properties

Cable design	Smooth
Cable construction	ÖLFLEX® CHARGE 5G 6mm ² +0.5
Cable designation	LAPP Kabel Stuttgart ÖLFLEX® CHARGE EVC 750/450 VAC EN 50620
Cable colour	Orange RAL 2003
Cable construction	PP extruded D 15.5 +/- 0.3mm
Version	3-phase plus 2x signal cables

Connector/coupling

Type 2 coupling Heavy Duty line	Power contacts (L1/L2/L3,N, PE) 240V-415V
Type 2 connector Heavy Duty line	Power contacts (L1/L2/L3,N, PE) 240V-415V
Connector/coupling signal contacts	2A (CP, PP) 30V DC
Contact surface	5-6µm Ag-coated
Coding resistor between PP and PE	220 Ohm +/- 1%;1W
Contact resistors	Improved electrical design due to additional soldering
Connector/coupling design	2K moulding (hard/soft)
Connector/coupling materials	Hard component PA 30%; soft component TPE
Connector/coupling logo	LAPP e-Mobility
Type 2 coupling cap	Protective cap with Velcro
Maximum charging current	32A 3ph AC
Connector/coupling colour	Orange/black

General properties

Protection rating	IP44 with protective cap; IP24 without protective cap; tested for increased protection rating IP67
Standard	IEC 62196-1; IEC 62196-2; IEC 61851-1
Approvals	VDE certified and CE compliant
Directives	2014/35/EU (Low Voltage Directive), 2011/65/EU (RoHS), 215/863/EU



Lapp Mobility GmbH
Stuttgart Headquarters
Oskar-Lapp-Str. 2 · D-70565 Stuttgart
Phone: +49 711 7838 - 04
Fax: +49 711 7838 - 3520
www.lappmobility.com