

The power to innovate

KABELSCHLEPP

GENERAL CATALOG



CABLE CARRIER SYSTEMS MADE OF PLASTIC

CABLE CARRIER SYSTEMS MADE OF STEEL

LIFE-LINE SAFETY CABLES

GUIDEWAY PROTECTION SYSTEMS

CONVEYOR SYSTEMS

Contents



Copyright

Illustrations and text in this catalog are purely informative and, in part, only exemplary. They do not represent any quality guarantee and do not assure suitability for a particular application. This catalog is subject to technical and optical changes. Orders to be placed in the future are subject to the legally agreed quality of the relevant product, or otherwise the quality of each product as it was at the time of the signing of the contract.

All rights of this catalog are reserved, including text and illustrations, as well as brand names and corporate logos/trademarks used, in particular the rights of photocopying, distribution, translation or any other form of editing as well as the right of public reproduction.

No part of this catalog, including brand names and corporate logos/trademarks may be reproduced, processed, photocopied or distributed in any form or by any means, especially optical, photo-mechanical, paper-based or electronic, without prior written permission of KABELSCHLEPP GmbH.

Except hereof is the legally authorized use of photo-copying for merely private purposes (paragraph 53 German copyright law)

Our current terms and conditions of sales and delivery can be found at kabelschlepp.de

© 2009 - KABELSCHLEPP GmbH, D-57482 Wenden-Gerlingen

Cable carriers made of plastic

BASIC-LINE / BASIC-LINE^{PLUS}

Plastic cable carriers with fixed chain widths

VARIO-LINE

Cable carriers with fixed chain widths

TUBE-SERIES

Covered cable carriers and flexible energy conduits

3D-LINE

Cable carriers for 3D movements

1

Cable carriers made of steel

STEEL-LINE

Steel cable carriers –
from light-weight and economical to extremely robust and stable

LIFE-LINE Safety Cables

Cables for cable carriers

Control cables · Power cables · Data cables

BUS-/LVVL-/Coaxial cables · System cables

USB / CAT5 · Signal cables

TOTALTRAX Complete Systems

Cable carrier, cable and connector – connection-ready

2

Guideway Protection and Conveyor Systems

Conveyor systems

Hinged belt conveyors

Scraper conveyors · Belt conveyors

Guideway protection systems

Telescopic covers · Way wipers · Link apron covers

Bellows · Conical spring covers · Roll-up covers

Protective devices

PROTECT-PANEL machine housings

3



KABELSCHLEPP

The power to innovate

We are the inventors of the cable and hose carrier, in German "Kabelschlepp", which is also the name of our company. We have been carrying out systematic development work in this field for more than 50 years, and in the fields of guideway protection and conveyor systems for a number of decades.

Our range extends from individual components to system solutions, from standard products to custom-manufactured individual solutions. The application areas of our products are thus just as numerous as the variants in our product range.

Wherever shorter production times, higher batch numbers, longer service lives and faster tool changing are required; these are just a few examples of where our products can be used – in addition to cranes, vehicles and in many other fields.

kabelschlepp.de

Future-oriented investment, strategic expansion

We invest in highly-qualified employees and cutting-edge manufacturing facilities. All in order to supply the product suitable for your application quickly. Our ultramodern plant in Gerlingen is completely oriented towards quick delivery of our products and system solutions. For us, expansion means always being present where our customers need us.

At present we are represented by 14 subsidiaries and partners in more than 40 countries, employing a total of 800 people. Our employees' decades of experience and applications expertise mean that you will always receive a solution for your application.

In concrete terms this means that we will implement for you a balanced mix of technical and economic customer value.

General catalog
2009 / 2010

3 in 1 – Bundling forces and using synergies

In this edition we have brought
our product range together
in an general catalog.

Benefit from our know-how in the product areas cable carriers, LIFE-LINE safety and guideway protection and conveyor systems.

All of our ideas for every aspect of the machine – in a compact and handy format:

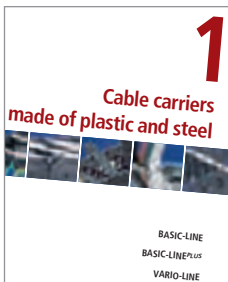

Cable Carriers
Everything about cable carriers can be found starting on page 11.

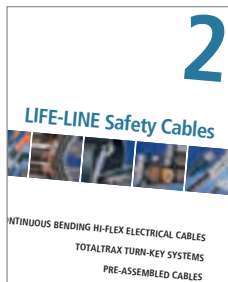

LIFE-LINE Safety Cables
Our complete cable range – starting on page 345.

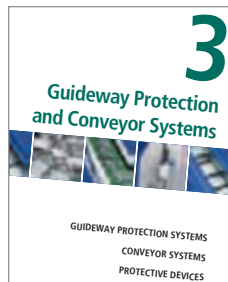

Guideway Protection and Conveyor Systems
Conveyors, covers, housings and much more – starting on page 433.

KABELSCHLEPP is a provider of solutions, e.g.:

TOTALTRAX – connection-ready and „just-in-time“

Reduce costs and planning time and effort. Our specialists will support you from the very start. From the planning to installation. Cable carriers, cables and connectors – matched components, ready to install and with a warranty for the entire system.



„Just-in-time“ delivery and service from a single source

With TOTALTRAX complete systems you save storage costs – we deliver “just in time” in accordance with your production cycles. Upon request, we will configure the entire system according to your construction plans, including assembly plates and fastening elements. For us, special transport frames or packaging to suit your needs go without saying.



TOTALTRAX Complete System
with assembly plates

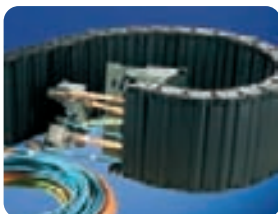

Ready-to-install system with cable
carrier, cables and connectors



Complete assembly and commissioning
with system guarantee

KABELSCHLEPP is a provider of solutions, e.g.:

Emergency Cable Carrier – Security for long travel lengths

Blockages in the travel lengths of cable carriers in large systems can destroy the entire cable carrier system. This results in high costs and downtime for the entire system. The new ECC – Emergency Cable Carrier minimizes downtimes and avoids repair costs.



ECC
KABELSCHLEPP
Emergency Cable Carrier

Emergency Cable Carrier System with additional emergency stop system

During use in harsh environments, objects can enter the carrier's path of travel, thus blocking it. ECC detects this and switches the system off safely. In addition to the Emergency Stop function, ECC also offers a bridging safeguard for the braking distance. Areas of application: Applications with long travel lengths, e.g. crane, port, compost or coal conveyor systems, steel works and raw materials systems.



Bridging safeguard of the braking distance in both directions of travel



Automatic emergency cutout with decoupling of the cable carrier



Simply couple again; the system is ready for operation again immediately

KABELSCHLEPP is a provider of solutions, e.g.:

Conveyor systems – Disposal on production machines

Our scraper belt, hinged belt and belt conveyors embody more than 30 years of experience. Systematic further development of our products and adaptation of their functions for use with the latest generation of machines guarantees you the utmost level of reliability.



From standard to customized – we have a solution

Conveyors are often used on cutting machine tools. The variable dimensions and designs of our standard conveyors are often sufficient in order to cover the needs of your application. For special requirements we can also plan and manufacture special conveyors, and design complete chip disposal systems with machine cleaning, crushing, workshop cleaning and hopper storage.



Hinged belt conveyors – proven for a wide range of disposal tasks



Scraper conveyors – for disposal of small materials



Belt conveyors – the all-rounders – also for parts with sharp edges

KABELSCHLEPP is a provider of solutions, e.g.:

Telescopic covers – perfect protection for guideways

Wherever guideways on machines have to be protected, we have a suitable solution. Our guideway protection systems boast a high degree of operational reliability, a long service life, and make use of innovative technical solutions – customized of your application.

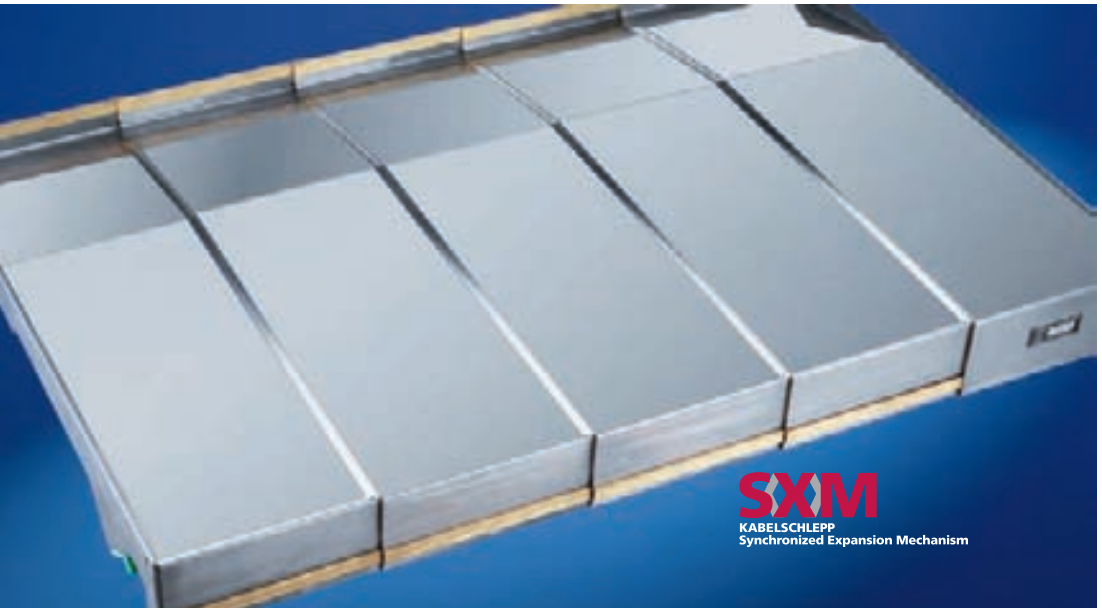

Telescopic cover with harness mechanism

To ensure impact-free expansion / compression of telescopic covers, they are used with so-called synchronisers (harnesses). As a result, all of the cover boxes move evenly during expansion and compression.

The individual boxes move relative to each other only at a differential speed.



Harness mechanics for impact-free expansion or compression



Solution with one harness for "small" machine tools



Maintenance-free harness with sliding bearings of high-performance plastic

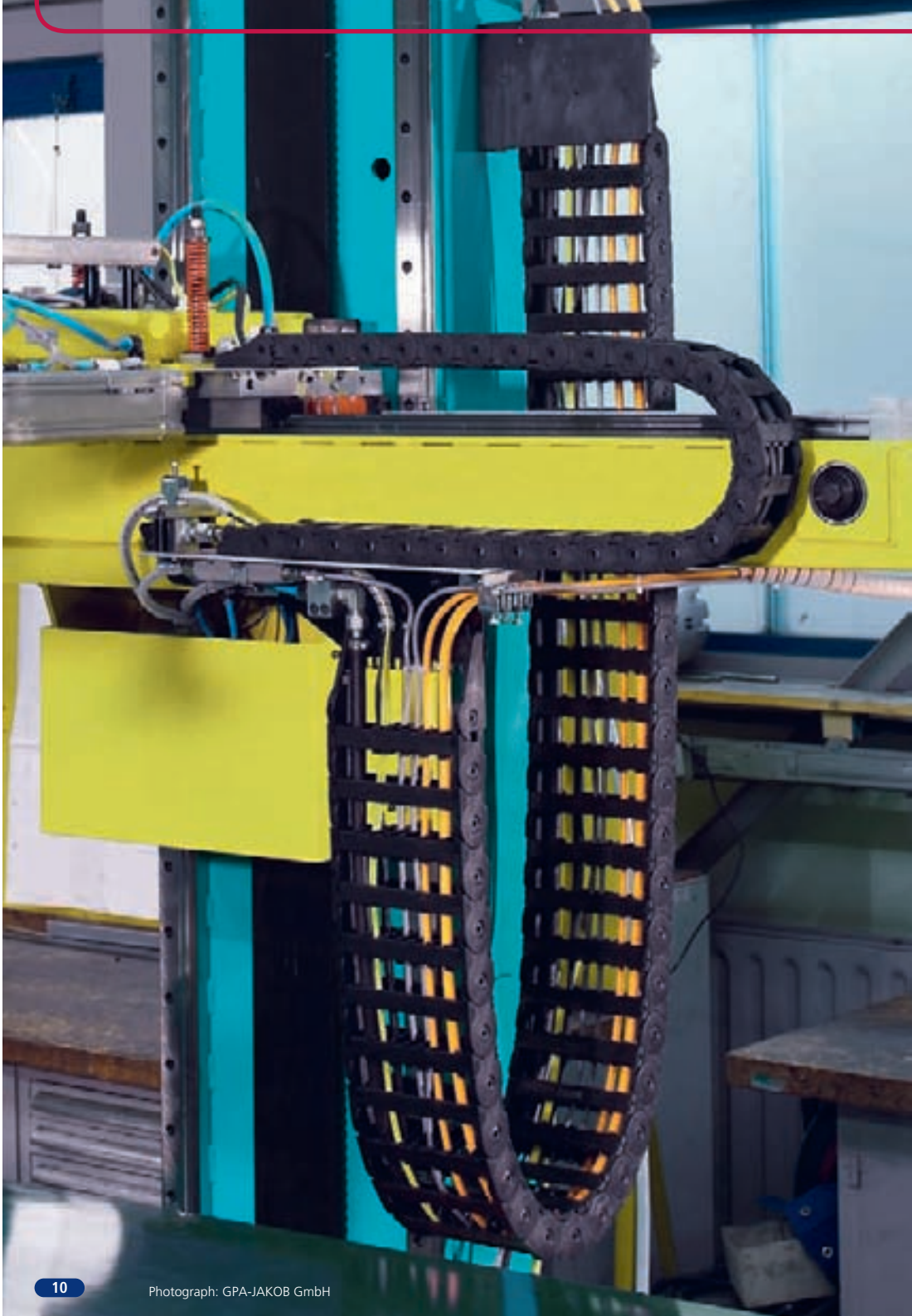

1

Cable carriers made of plastic and steel



BASIC-LINE

BASIC-LINE^{PLUS}

VARIO-LINE

TUBE SERIES

3D-LINE

STEEL-LINE

Accessories

Overview cable carriers made of plastic and steel

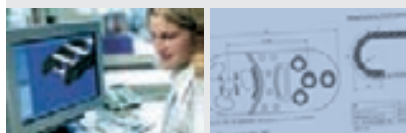

Laying out
of cable carriers



BASIC-LINE

Solid plastic cable carriers
with fixed chain widths

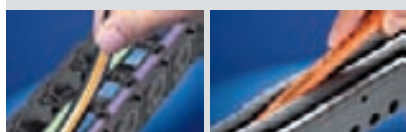

BASIC-LINE^{PLUS}

Solid plastic cable carriers
with fixed chain widths

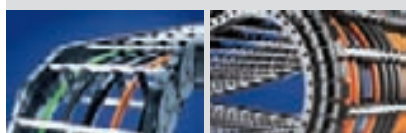

VARIO-LINE

Cable carriers
with variable chain widths



TUBE SERIES

Covered cable carriers
and flexible energy conduits



3D-LINE

Cable carriers
for 3D movements

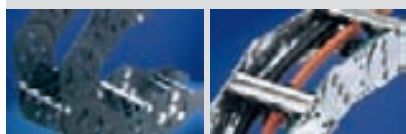

STEEL-LINE

Steel cable carriers

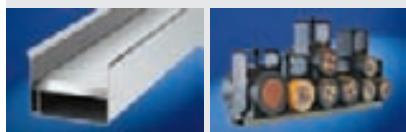

Accessories
Application examples
Ordering

	page
Overview of important abbreviations	16
Guideline for fast product selection	18
Overview of inside heights	30
Step by step to the suitable cable carrier	32

MONO	54
QuickTrax	74
UNIFLEX <i>Advanced</i>	82
UNIFLEX	94

EasyTrax	110
PROTUM	118
PROFILE	124

K Series	132	XL Series	180
MASTER Series	148	QUANTUM	186
M Series	158	TKR 0200	194

CoverTrax	200	Steel carriers	241
UNIFLEX TUBES	208	CONDUFLEX	242
MASTER TUBES	218	MOBIFLEX	243
MT Series	228		
XLT Series	237		

ROBOTRAX	244
----------	-----

LS/LSX Series	254
S/SX Series	262
CONDUFLEX	282
MOBIFLEX	288

Guide channels	295	Application examples	315
Trays	294	Ordering	331
Strain relief devices	301		
Assembly profile bars	307		
Installation variants	309		

Table of abbreviations on the back side,
please open up.



Do stop by our page on the internet:



General abbreviations

a_T	=	Distance from inside of side chain link up to the middle of the first/last divider
a_x	=	Divider center-to-center distance
h_{1-4}	=	Distance of the height division in the divider
B_{EF}	=	Total width of the cable carrier across the connection
B_{EF}'	=	Total width of the cable carrier with sliding discs (K Series) and glide shoes (QUANTUM)
B_i	=	Inside width in the chain/hose cross-section
B_k	=	Width of the cable carrier
B_{St}	=	Stay width in case of hole stays
b_A	=	Distance between the connection holes
c	=	Distance between the holes in case of hole stays ($c_{min} = 4 \text{ mm}$)
d	=	Cable outer diameter
d_R	=	Tube diameter in case of plastic-roller stays
D	=	Hole diameter
q_k	=	Weight of the cable carrier (without connection)
h_G	=	Chain link height
h_G'	=	Chain link height including glide shoe
h_i	=	Inside height in the chain/hose cross-section
H	=	Connection height
H_i	=	Inside height in the top-mounted-frame stay
H_z	=	Mounting height
KR	=	Bend radius of the cable carrier
l_A	=	Length of the connector
l_{1-4}	=	Connection dimensions
L_B	=	Bend length
L_D	=	Length with permitted sag
L_f	=	Unsupported length
L_k	=	Length of the cable carrier
L_{ES}	=	Length of the cable carrier conduit
L_S	=	Max. length of the travel path
L_V	=	Fixed point displacement
n_Z	=	Number of comb teeth (strain relief) on one comb side
q_Z	=	Additional load
t	=	Pitch
s_T	=	Divider thickness
s_H	=	Thickness of the height division
\ddot{U}_B	=	Loop overhang (depot)

Overview of important abbreviations:

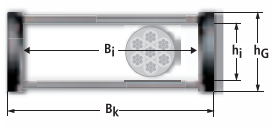
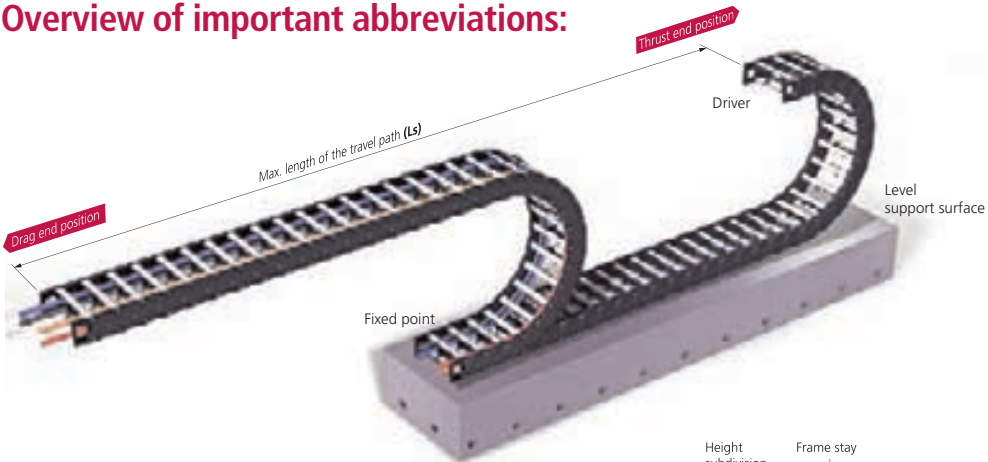

- B_i = Inside width in the chain/hose cross-section
- B_k = Width of the cable carrier
- h_i = Inside height in the chain/hose cross-section
- h_G = Chain link height

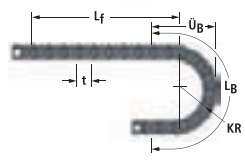

- KR = Bend radius of the cable carrier
- L_B = Bend length
- L_f = Unsupported length
- t = Pitch
- \ddot{U}_B = Loop overhang (Depot)

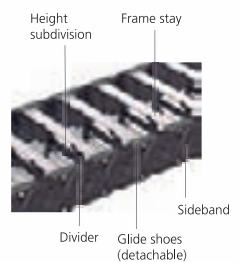

Cut down your construction times

2D and 3D data of our cable carriers on the World Wide Web

Accelerate your design processes with our 2D and 3D models from the CAD component libraries. Data for our cable carriers is available in the **CADENAS** and **TRACEPARTS** component libraries. The download of all product data in both libraries is free of charge. Native data and all common export formats are available for all common CAD systems.



- CADENAS**
- easy to connect to PDM and ERP systems
 - the PARTSolutions catalog can be accessed easily using a button in Autodesk Inventor
 - detailed chain models are available

- TRACEPARTS**
- most KABELSCHLEPP cable carriers are available
 - worldwide, the only CAD library with "CAA" (CATIA) partner status
 - also available on CD at no charge – please contact us



With just a few clicks of the mouse to an optimal KABELSCHLEPP cable carrier system

Online configuration for KABELSCHLEPP cable carrier systems

Using the **OnlineEngineer** you can **quickly, dependably and flexibly** design the KABELSCHLEPP cable carrier system with the optimal price/performance ratio!

Laying out your cable carrier system with the OnlineEngineer.

Just input the parameters of your application and the OnlineEngineer will **automatically calculate** the KABELSCHLEPP cable carrier system with the **optimal price/performance ratio!** Alternatively you can follow the **step-by-step** menus and individually design your desired cable carrier system. If you already know which KABELSCHLEPP cable carrier system you would like to employ just enter the order specifications and you will receive all applicable information by mouse click.

The distribution of the carriers with a chain cross-section can also be defined easily. With the click of the mouse you'll receive a to-scale **diagram in CAD format**. Any and all functions can be combined so that it will only be necessary for you to enter the required information once and so that you can remain flexible in your design. As soon as you have laid out your cable carrier you can **download** a corresponding **2D diagram** or a **3D model**.



OnlineEngineer.de

KABELSCHLEPP
Cable Carrier Configurator







www.OnlineEngineer.de

- economical due to optimal price/performance ratio in the design of KABELSCHLEPP cable carrier system
- time savings through automatic layout function
- transparency: all information of the cable carrier system is displayed as a glance
- efficiency through linking with 2D & 3D data for download
- online price inquiry to KABELSCHLEPP









Guideline for fast product selection

Series	Type	 Inside height h_i in mm		 Inside width B_i in mm		 Bend radii in mm		Maximum travel length in m	Dynamics of unsupported arrangement	
		from	to	min.	max.	Travel speed v_{max} m/s	Travel acceleration a_{max} m/s ²			
BASIC-LINE										
MONO – cable carriers with simple design for standard applications										
	MONO 0130	10	6	40	20	37	40	10	50	
	MONO 0132	10	6	40	20	37	40	10	50	
	MONO 0180	15	10	40	28	50	70	10	50	
	MONO 0182	15	10	40	28	50	70	10	50	
	MONO 0202	11	6	20	18	50	70	10	50	
	MONO 0320	19	13	37	37	100	80	10	50	
	MONO 0450	24/28	38	103	52	200	120	10	50	
MONO 0625	34/42	65	169	75	300	130	8	40		
QuickTrax – compact and cost-effective cable carriers in two-component technology										
	QT 0320.030	20	15	50	28	125	80	10	50	
	QT 0320.040	20	15	50	28	125	80	10	50	
UNIFLEX Advanced – light, quiet all-rounder with wide range of applications										
	1455.020	26	25	103	52	225	120	10	50	
	1455.030	26	25	103	52	225	120	10	50	
	1455.040	26	25	103	52	225	120	10	50	
	1555.020	38	50	150	63	230	125	9	45	
	1555.030	38	50	150	63	230	125	9	45	
	1555.040	38	50	150	63	230	125	9	45	
	1665.020	44	50	250	75	300	150	8	40	
	1665.030	44	50	250	75	300	150	8	40	
1665.040	44	50	250	75	300	150	8	40		
UNIFLEX – proven cable carrier with many opening and cover variants										
	0250.030	17.5	20	80	28	100	60	10	50	
	0345.030	20	15	90	38	150	80	10	50	
	0345.040	20	15	90	38	150	80	10	50	
	0345.050	20	15	65	38	150	80	10	50	
	0345.060	19.5	15	65	75	150	80	10	50	
	0455.030	26	25	130	52	225	120	10	50	
	0455.040	26	25	130	52	225	120	10	50	
	0455.050	26	25	130	52	225	120	10	50	
	0455.060	25	25	130	95	225	120	10	50	
	0555.030	38	50	150	63	230	125	9	45	
	0555.040	38	50	150	63	230	125	9	45	
	0555.050	38	50	150	63	230	125	9	45	
	0555.060	36	50	150	100	230	125	9	45	
	0665.030	44	50	250	75	300	150	8	40	
	0665.040	44	50	250	75	300	150	8	40	
	0665.050	44	50	175	75	300	150	8	40	
	0665.060	42	50	175	120	300	150	8	40	
	0600.080	44	50	125	100	200	100	6	35	

Cable carriers made of plastic

Opening options				Technical data see page	Type
Enclosed frame – not openable	Crossbars can be opened on the outside	Crossbars can be opened on the inside	Cover system – TUBES		
BASIC-LINE					
MONO – cable carriers with simple design for standard applications					
	■			56	MONO 0130
■				56	MONO 0132
	■			56	MONO 0180
■				56	MONO 0182
■				56	MONO 0202
■				56	MONO 0320
■	■			57	MONO 0450
■	■			57	MONO 0625
QuickTrax – compact and cost-effective cable carriers in two-component technology					
	■			76	QT 0320.030
		■		76	QT 0320.040
UNIFLEX <i>Advanced</i> – light, quiet all-rounder with wide range of applications					
■				84	1455.020
	■			84	1455.030
		■		85	1455.040
■				84	1555.020
	■			84	1555.030
		■		85	1555.040
■				84	1665.020
	■			84	1665.030
		■		85	1665.040
UNIFLEX – proven cable carrier with many opening and cover variants					
	■			96	0250.030
	■			96	0345.030
		■		96	0345.040
		■		97	0345.050
			■	209	0345.060
	■			96	0455.030
		■		96	0455.040
		■		97	0455.050
			■	209	0455.060
	■			96	0555.030
		■		96	0555.040
		■		97	0555.050
			■	209	0555.060
	■			96	0665.030
		■		96	0665.040
		■		97	0665.050
			■	209	0665.060
			■	209	0600.080

Guideline for fast product selection





Series	Type	 Inside height h_i in mm	 Inside width B_i in mm		 Bend radii in mm		Maximum travel length in m	Dynamics of unsupported arrangement		
			from	to	min.	max.		Travel speed v_{max} m/s	Travel acceleration a_{max} m/s ²	
BASIC-LINE^{PLUS}										
EasyTrax – extremely quick cable laying, extra-stable thanks to two-component technology										
	ET 0320.030	18	15	50	28	125	80	10	50	
	ET 0320.040	18	15	50	28	125	80	10	50	
PROTUM – small, light cable carrier for unsupported applications										
	P 0160	15	15	30	18	48	–	–	–	
	P 0240	20	20	40	27	72	–	–	–	
	P 0300	25	25	45	34	90	–	–	–	
PROfile [®] – cable carrier for short travel lengths and high travel speeds										
	EM-1212	34	–	32	75	250	–	–	–	
	EM-1717	34	–	42	75	250	–	–	–	
	EM-2222	34	–	52	75	250	–	–	–	
	EM-2727	34	–	62	100	250	–	–	–	
	EM-3232	34	–	72	100	250	–	–	–	
	EM-S15	6	–	17.5	–	–	–	–	–	
	EM-S43.20	20	–	48	–	–	–	–	–	
	EM-S45.20	20	–	49	–	–	–	–	–	
	EM-S45.16.5	16.5	–	49	–	–	–	–	–	
	EM-S67.11	11	–	72	–	–	–	–	–	
	QM-45.23	23.5	–	50	–	–	–	–	–	

* The carrier width values of the PROfile[®] series refer to the outer width of the carrier.

Cable carriers made of plastic

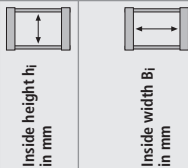
Closed	Laying the cable		Technical data see page	Type
	in the inner radius	in the outer radius		
BASIC-LINE^{PLUS}				
EasyTrax – extremely quick cable laying, extra-stable thanks to two-component technology				
		■	112	ET 0320.030
	■		112	ET 0320.040
PROTUM – small, light cable carrier for unsupported applications				
		■	120	P 0160
		■	120	P 0240
		■	120	P 0300
PROfile® – cable carrier for short travel lengths and high travel speeds				
		■	126	EM-1212
		■	126	EM-1717
		■	126	EM-2222
		■	126	EM-2727
		■	126	EM-3232
	■		129	EM-S15
		■	129	EM-S43.20
		■	129	EM-S45.20
		■	129	EM-S45.16.5
		■	129	EM-S67.11
	■		129	QM-45.23

Guideline for fast product selection

Series	Type	 Inside height h_i in mm		 Inside width B_i in mm		 Bend radii in mm		Maximum travel length in m	Dynamics of unsupported arrangement	
		from	to	min.	max.	Travel speed v_{max} m/s	Travel acceleration a_{max} m/s ²			
VARIO-LINE										
K Series – cost-effective, robust cable carrier also suitable for large additional loads										
	KC 0650	38	75	400	75	300	220	8	40	
	KE 0650	42	68	260	75	300	220	8	40	
	KC 0900	58	100	500	130	385	260	6	30	
	KE 0900	58	81	561	130	385	260	6	30	
MASTER Series – quiet and weight-optimized cable carriers										
	HC 33	33	50	400	60	300	60	10	50	
	HT 33	33	50	400	100	300	50	10	50	
	HC 46	46	50	400	75	350	80	8	40	
	HT 46	46	50	400	125	350	70	8	40	
	LC 60	60	75	600	135	500	7*	6	30	
	LT 60	60	53	600	150	500	6.8*	6	30	
	LC 80	80	100	800	150	500	8*	5	25	
LT 80	80	100	800	200	500	7.6*	5	25		
M Series – multivariable cable carrier with extensive accessories and stay variants										
	MC 0320	19	25	280	37	200	80	10	50	
	ME 0320	19	25	149	37	200	80	10	50	
	MK 0475	28	24	280	55	300	120	10	50	
	MT 0475	26	24	280	75	300	100	10	40	
	MC 0650	38	75	500	75	350	220	8	40	
	ME 0650	42	50	266	75	350	220	8	40	
	MK 0650	42	50	258	75	350	220	8	40	
	MT 0650	38.5	50	500	95	350	170	8	35	
	MC 0950	58	100	600	140	380	260	6	30	
	ME 0950	58	45	557	140	380	260	6	30	
	MK 0950	58	45	557	140	380	260	6	30	
	MT 0950	54.5	100	600	140	380	230	6	25	
	MC 1250	72	100	800	180	500	320	5	25	
	ME 1250	72	71	551	180	500	320	5	25	
	MK 1250	72	71	551	180	500	320	5	25	
	MT 1250	68.5	150	800	220	500	270	5	20	
	MC 1300	87	100	800	150	500	350	5	25	
	MT 1300	87	100	800	240	500	300	5	20	

* only unsupported

Stay variants / stay designs

RS/RSH/RSL – frame stay
For lightweight to medium loads –
with quickly detachable aluminum stays

RM – frame stay, solid design
Aluminum stays screwed on –
high stability, for maximum stay widths

**RMS – frame stay, solid design
with ball joint**
Aluminum stays with ball joint can be opened
quickly and easily on both sides.

RV – frame stay, reinforced design
For medium to heavy loads –
with quickly detachable aluminum stays

**RMF – frame stay, solid design
with optional fixing strip**
Aluminum stays easily screwed on –
high stability

RMR – roller stay system
Aluminum stays screwed on –
with plastic roller system

Cable carriers made of plastic

Stay variants											Technical data see page	Type
Frame stay RS/RS/RS/L	Frame stay RV	Frame stay RM/RM/RMS	Frame stay RMR	Frame stay RE	Frame stay RD	Frame stay RDD/RDL/RDH	Frame stay RMD/RML	Frame stay RMA	Hole stay LG			
VARIO-LINE												
K Series – cost-effective, robust cable carrier also suitable for large additional loads												
■											134	KC 0650
				■							134	KE 0650
■	■										134	KC 0900
				■							134	KE 0900
MASTER Series – quiet and weight-optimized cable carriers												
■											150	HC 33
						■					220	HT 33
■											150	HC 46
						■					220	HT 46
■											150	LC 60
						■		■			220	LT 60
■											150	LC 80
								■			220	LT 80
M Series – multivariable cable carrier with extensive accessories and stay variants												
■											160	MC 0320
				■							160	ME 0320
					■						161	MK 0475
						■	■				230	MT 0475
■								■	■		160	MC 0650
				■							160	ME 0650
					■						161	MK 0650
						■	■				230	MT 0650
■	■	■	■					■	■		160	MC 0950
				■							160	ME 0950
					■						161	MK 0950
						■	■				230	MT 0950
	■	■	■					■	■		160	MC 1250
				■							160	ME 1250
					■						161	MK 1250
						■	■				230	MT 1250
		■							■		160	MC 1300
							■				230	MT 1300

RE – frame stay

With quickly unscrewable plastic stays outside and inside

RDD/RDH/RDL – frame stay, cover system – covered cable carrier

Plastic cover for opening inside and outside

RMA – mounting frame stay

For very large cable diameters such as with air hoses

RD – frame stay

With quickly unfoldable/removable plastic stays outside or inside







RMD/RML – frame stay, cover system – covered cable carrier

Aluminum cover for opening inside and outside

LG – hole stay – split design

Optimum cable routing in the neutral bending line

Guideline for fast product selection

Series	Type	 Inside height h_i in mm		 Inside width B_i in mm		 Bend radii in mm		Maximum travel length in m	Dynamics of unsupported arrangement	
		from	to	min.	max.	Travel speed v_{max} m/s	Travel acceleration a_{max} m/s ²			
VARIO-LINE										
XL Series – cable carrier with large inside height										
	XLC 1650	108	200	1000	250	550	350	4	25	
	XLT 1650	105	200	1000	250	550	300	4	20	
QUANTUM – link-free cable carrier – light, extremely quiet and low vibration for high speeds and accelerations										
	Q 040	28	28	284	60	180	100	40	300	
	Q 060	42	38	500	100	300	150	30	160	
	Q 080	58	50	600	170	500	180	25	100	
	Q 100	72	70	600	180	600	200	20	70	
TKR 0200 – extremely quiet and low-vibration for highly dynamic applications										
	TKR 0200	28	40	100	55	150	2.8	10	200	

Stay variants / stay designs

RS – frame stay

For lightweight to medium loads – with quickly detachable aluminum stays

RM – frame stay, solid design

Aluminum stays screwed on – high stability, for maximum stay widths

RE – frame stay

With quickly unscrewable plastic stays outside and inside

RV – frame stay, reinforced design

For medium to heavy loads – with quickly detachable aluminum stays

RMR – roller stay system

Aluminum stays screwed on – with plastic roller system

RD – frame stay

With quickly unfoldable/removable plastic stays outside or inside

Cable carriers made of plastic

Stay variants							Technical data see page	Type
Frame stay RS	Frame stay RV	Frame stay RM	Frame stay RMR	Frame stay RE	Frame stay RMD	Hole stay LG		
VARIO-LINE								
XL Series – cable carrier with large inside height								
		■	■			■	182	XLC 1650
					■		237	XLT 1650
QUANTUM – link-free cable carrier – light, extremely quiet and low vibration for high speeds and accelerations								
				■			188	Q 040
■				■			188	Q 060
■	■			■			188	Q 080
■	■			■			188	Q 100
TKR 0200 – extremely quiet and low-vibration for highly dynamic applications								
							196	TKR 0200

RDD – frame stay, cover system – covered cable carrier
Plastic cover for opening inside and outside





RMA – mounting frame stay
For very large cable diameters such as with air hoses

RMD – frame stay, cover system – covered cable carrier
Aluminum cover for opening inside and outside

LG – hole stay – split design
Optimum cable routing in the neutral bending line

Subject to change.

Guideline for fast product selection

Series	Type	Cross-section diagrams		Bend radii		Maximum travel length in m	Dynamics of unsupported arrangement		Technical data see page	
		Inside height h_i in mm	Inside width B_i in mm	min.	max.		Travel speed v_{max} in m/s	Travel acceleration a_{max} in m/s ²		
TUBE-SERIES										
CoverTrax – extreme cable protection in harsh environmental conditions										
	CT 1555	50	50	250	100	300	100	6	35	202
UNIFLEX TUBES – proven solid cable carriers with fixed carrier width										
	0345.050¹⁾	20	15	65	38	150	80	10	50	208
	0345.060	19,5	15	65	75	150	80	10	50	209
	0455.050¹⁾	26	25	130	52	225	120	10	50	208
	0455.060	25	25	130	95	225	120	10	50	209
	0555.050¹⁾	38	50	150	63	230	125	9	45	208
	0555.060	36	50	150	100	230	125	9	45	209
	0655.050¹⁾	44	50	175	75	300	150	8	40	208
	0655.060	42	50	175	120	300	150	8	40	209
	0600.080	44	50	125	100	200	100	6	35	209
MASTER TUBES – quiet and weight-optimized cable carriers										
	HT 33 RDH	33	50	400	100	300	50	10	50	218
	HT 46 RDH	46	50	400	125	350	70	8	40	218
	LT 60 RDL	60	53	300	150	500	6,8 ²⁾	6	30	219
	LT 60 RML	60	75	600	150	500	6,8 ²⁾	6 ³⁾	30 ³⁾	219
	LT 80 RML	80	100	800	200	500	7,6 ²⁾	5 ³⁾	25 ³⁾	219
MT-Series – multivariable cable carrier with extensive accessories										
	MT 0475 RDD	26	24	280	75	300	100	10	40	228
	MT 0650 RDD	38,5	50	258	95	350	170	8	35	228
	MT 0950 RDD	54,5	77	349	140	380	230	6	25	228
	MT 1250 RDD	68,5	103	359	220	500	270	5	20	228
	MT 0475 RMD	26	24	180	75	300	100	10	40	229
	MT 0650 RMD	38,5	100	500	95	350	170	8	35	229
	MT 0950 RMD	54,5	100	600	140	380	230	6	25	229
	MT 1250 RMD	68,5	150	800	220	500	270	5	20	229
	MT 1300 RMD	87	100	800	240	500	300	5	20	229
XLT-Series – cable carriers with large inside height										
	XLT 1650	105	200	1000	250	550	300	4	20	237

1) covered on one side (outside)

2) only unsupported

3) possible maximum values for small carrier widths







Cable carriers made of plastic or steel

Series	Type					Maximum travel length in m	Dynamics of unsupported arrangement		Technical data see page	
		Inside height h_i in mm	Inside width B_i in mm	min.	max.		Travel speed v_{max} m/s	Travel acceleration a_{max} m/s ²		
TUBE-SERIES										
STEEL-TUBES – extremely robust and stable steel chains										
	S/SX 0650 RMD	30	70	400	75	300	6 ⁴⁾	60	a.A.	241
	S/SX 0950 RMD	44	125	600	125	410	9 ⁴⁾	60	a.A.	241
	S/SX 1250 RMD	69	130	800	145	1000	12 ⁴⁾	150	a.A.	241
	S/SX 1850 RMD	104	250	1000	265	1405	18 ⁴⁾	200	a.A.	241
CONDUFLEX – closed designer cable carrier										
	CF 055	25	45	–	65	150	3	10	20	242
	CF 060	40	36	–	100	–	3,5	10	20	242
	CF 085	38	73	–	100	250	4	8	18	242
	CF 115	52	102	–	140	300	5	8	16	242
	CF 120	70	100	–	155	200	5,5	6	15	242
	CF 175	72	162	–	185	350	6	6	12	242
MOBIFLEX – enclosed cable carrier with flexible metal helical tube										
	MF 030.1	24	26	–	80	–	2	10	20	243
	MF 050.1	24	45	–	75	150	3	10	20	243
	MF 050.2	44	45	–	110	200	3	10	20	243
	MF 080.1	40	80	–	100	200	3,5	10	18	243
	MF 080.2	54	80	–	150	250	3,5	10	18	243
	MF 080.3	78	80	–	200	–	3,5	10	18	243
	MF 110.1	53	109	–	150	250	4	6	15	243
	MF 110.2	73	109	–	200	350	4	6	15	243
	MF 110.3	108	109	–	300	–	4	6	15	243
	MF 170.1	72	170	–	190	350	5	6	12	243
	MF 170.2	102	170	–	250	400	5	6	12	243
MF 170.3	167	170	–	365	–	5	6	12	243	

⁴⁾ Max. value for type S (unsupported); steel band covers are also available as alternatives to cover systems, see page 280

Series	Type					Technical data see page
		Inside height h_i in mm	Inside width B_i in mm			
3D-LINE						
ROBOTRAX – cable carriers for 3D movements						
	R 040	10	27	80	40	247
	R 056	14	39	115	56	247
	R 075	22	52	145	75	247
	R 085	24	54	175	85	247
	R 100	31	64	195	100	247

Guideline for fast product selection

Series	Type	 Clearance height ^{A)} h _i in mm		 Chain width ^{A)} B _k in mm		 Bend radii in mm		Maximum travel length in m	Dynamics of unsupported arrangement	
		from	to	min.	max.	Travel speed ^{C)} v _{max} m/s	Travel acceleration a _{max} m/s ²			
STEEL-LINE										
LS/LSX Series – lightweight cable carriers with steel chain bands ^{B)}										
	LS/LSX 1050	58	100	600	105	430	10	5 ^{F)}	10	
S/SX Series – cable carriers with steel chain bands ^{B)}										
	S/SX 0650	31	70	500	75	400	6	2.5	5	
	S/SX 0950	46	125	600	125	600	9	2.5	5	
	S/SX 1250	72	130	800	145	1000	12	2.5	5	
	S/SX 1800	108	180	1000	265	1405	18	2	3	
	S/SX 2500	183	250	1200	365	1395	24	2	3	
	S/SX 3200	220	250	1500	470	1785	25	2	2.5	
	S/SX 5000	150	150	1000	500	1200	12	2	3	
	S/SX 6000	240	200	1200	700	1500	18	1.5	2	
	S/SX 7000	370	300	1500	1100	2400	25	1	1	
CONDUFLEX – closed designer cable carrier										
	CF 055	25	–	45	65	150	3	10	20	
	CF 060	40	–	36	–	100	3.5	10	20	
	CF 085	38	–	73	100	250	4.5	8	18	
	CF 115	52	–	102	140	300	5	8	16	
	CF 120	70	–	100	155	200	5.5	6	15	
	CF 175	72	–	162	185	350	6	6	12	
MOBIFLEX – enclosed cable carrier with flexible metal helical tube										
	MF 030	24	–	26	–	80	3	10	20	
	MF 050	44	–	45	75	200	3	10	20	
	MF 080	78	–	80	100	200	4	10	18	
	MF 110	108	–	109	150	300	4	6	15	
	MF 170	167	–	170	190	365	5	6	12	

Stay variants / stay designs

RS 1 – frame stay, narrow version

Variant RS 1 – with quick-release aluminium stays on the outside or inside

RM – frame stay, solid version

Aluminium stays bolted on both sides – greatest stability, for maximum stay widths

RMA – mounting frame stay

Stay variant for large cable diameter

RS 2 – frame stay, narrow version

Variante RS 2 – with bolted aluminium stays

RMR – roller stay system

Aluminium stays bolted on both sides – with plastic roller system

RR – frame stay, tube version

Steel axles as connecting profiles with rotating metal tubes

RV – frame stay, reinforced version

Aluminium stays on the inside and outside bolted to the chain bands – high stiffness

RRD – frame stay, cover system – covered cable carrier

Aluminium cover bolted on both the inside and outside to the chain bands

LG – hole stay – split design

Aluminium stays – order-specific production – maximum degree of operating reliability

Cable carriers made of steel

Variants of carrier/hose cross-section											Cover with spring steel strip possible	Technical data see page	Type
Closed frame	Frame stay RS 2	Frame stay RS 1	Frame stay RV	Frame stay RM	Frame stay RMA	Frame stay RMR	Frame stay RR	Hole stay LG	Frame stay RMD				
STEEL-LINE													
LS/LSX Series – lightweight cable carriers with steel chain bands^{B)}													
	■		■		■		■	▲			on request	256	LS/LSX 1050
S/SX Series – cable carriers with steel chain bands^{B)}													
	■	■			■		■	▲	■	■		264	S/SX 0650
	■	■		■	■	■	■	▲	■	■		264	S/SX 0950
	■	■	■		■	■	■	▲	■	■		264	S/SX 1250
					■		■	▲		■		264	S/SX 1800
					■			▲		■		265	S/SX 2500
							●	▲				265	S/SX 3200
							●	●				265	S/SX 5000
							●	●				265	S/SX 6000
							●	●				265	S/SX 7000
CONDUFLEX – closed designer cable carrier													
■										■(E)		284	CF 055
■												284	CF 060
■										■(E)		284	CF 085
■										■(E)		284	CF 115
■												284	CF 120
■										■(E)		284	CF 175
MOBIFLEX – enclosed cable carrier with flexible metal helical tube													
■												289	MF 030
■												289	MF 050
■												289	MF 080
■												289	MF 110
■												289	MF 170

Reference:

- Standard
- ▲ Customized standard products
- Special order as per customer specifications

- A) dependent on the stay variant
- B) multi-band chains for larger widths possible
- C) values for S and LS versions; values for SX / LSX versions reduced by 0,5 m/s
- D) values for S and LS versions; see load diagram of the respective type for values for SX versions
- E) cover with protective straps possible
- F) Maximum value for fully-stayed design or design with central bolt

Cable carriers made of plastic or steel – Overview of inside heights

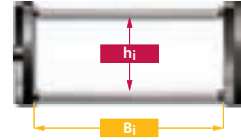

	Inside height h_i (mm)	Inside width B_i (mm)	Type	Series	Page
up to 10 mm	10	6-40	0130	MONO	56
	10	6-40	0132	MONO	56
	10	50	P 0240 GS	PROTUM OFFICE	122
	10	27	R 040	ROBOTRAX	247
11-15 mm	11	6-20	0202	MONO	56
	14	39	R 056	ROBOTRAX	247
	15	10-40	0180	MONO	56
	15	10-40	0182	MONO	56
	15	15-30	P 0160	PROTUM	120
17,5-20 mm	17,5	20-80	0250	UNIFLEX	96
	18	15-50	ET 0320	EasyTrax	112
	19	13-37	0320	MONO	56
	19	25-280	MC 0320	M Series	160
	19	25-149	ME 0320	M Series	160
	19,5	15-65	0345.060	UNIFLEX TUBES	209
	20	15-90	0345.030	UNIFLEX	96
	20	15-90	0345.040	UNIFLEX	96
	20	15-65	0345.050	UNIFLEX TUBES	208
	20	15-50	QT 0320	QuickTrax	76
	20	20-40	P 0240	PROTUM	120
	22-30 mm	22	52	R 075	ROBOTRAX
24		38-103	0450.x0	MONO	57
24		38-103	0450.x1	MONO	57
24		26	MF 030.1	MOBIFLEX TUBES	243
24		45	MF 050.1	MOBIFLEX TUBES	243
24		54	R 085	ROBOTRAX	247
25		25-130	0455.060	UNIFLEX TUBES	209
25		45	CF 055	CONDUFLEX TUBES	242
25		25-45	P 0300	PROTUM	120
26		25-103	1455.020	UNIFLEX <i>Advanced</i>	84
26		25-103	1455.030	UNIFLEX <i>Advanced</i>	84
26		25-103	1455.040	UNIFLEX <i>Advanced</i>	85
26		25-130	0455.030	UNIFLEX	96
26		25-130	0455.040	UNIFLEX	96
26		25-130	0455.050	UNIFLEX TUBES	208
26		24-280	MT 0475	M Series TUBES	228
28		38-103	0450.x2	MONO	57
28		24-280	MK 0475	M-Series	161
28		28-284	Q 040	QUANTUM	188
28		40-100	TKR 0200	TKR 0200	196
30	70-400	S/SX 0650	S/SX Series TUBES	241	
31-34 mm	31	64	R 100	ROBOTRAX	247
	31	70-500	S/SX 0650	S/SX Series	264
	33	50-400	HC 33	MASTER Series	150
	33	50-400	HT 33	MASTER TUBES	218
	34	65-108	0625.22	MONO	57
	34	65-108	0625.23	MONO	57
	34	65-108	0625.40	MONO	57
	34	65-108	0625.42	MONO	57
	34	65-108	0625.43	MONO	57
	34	2x 17	EM-1717	PROFILE	126
	34	2x 22	EM-2222	PROFILE	126
	34	2x 27	EM-2727	PROFILE	126
	34	2x 32	EM-3232	PROFILE	126
	34	2x 12	EM-1212	PROFILE	126
36-38 mm	36	50-150	0555.060	UNIFLEX TUBES	209
	38	50-150	1555.020	UNIFLEX <i>Advanced</i>	84
	38	50-150	1555.030	UNIFLEX <i>Advanced</i>	84
	38	50-150	1555.040	UNIFLEX <i>Advanced</i>	85
	38	50-150	0555.030	UNIFLEX	96
	38	50-150	0555.040	UNIFLEX	96
	38	50-150	0555.050	UNIFLEX TUBES	208
	38	73	CF 085	CONDUFLEX TUBES	242
	38	75-400	KC 0650	K Series	134

	Inside height h _i (mm)	Inside width B _i (mm)	Type	Series	Page	
38-40 mm	38	75-500	MC 0650	M Series	160	
	38.5	50-258	MT 0650	M Series TUBES	228	
	40	36	CF 060	CONDUFLEX TUBES	242	
42-46 mm	40	80	MF 080.1	MOBIFLEX TUBES	243	
	42	65-169	0625.x5	MONO	57	
	42	50-175	0665.060	UNIFLEX TUBES	208	
	42	68-260	KE 0650	K Series	134	
	42	50-266	ME 0650	M Series	160	
	42	50-258	MK 0650	M Series	161	
	42	38-500	Q 060	QUANTUM	188	
	44	50-175	1665.020	UNIFLEX <i>Advanced</i>	96	
	44	50-175	1665.030	UNIFLEX <i>Advanced</i>	96	
	44	50-175	1665.040	UNIFLEX <i>Advanced</i>	96	
	44	50-250	0665.030	UNIFLEX	96	
	44	50-250	0665.040	UNIFLEX	96	
	44	50-175	0665.050	UNIFLEX TUBES	208	
	44	50-125	0600.080	UNIFLEX TUBES	209	
	44	45	MF 050.2	MOBIFLEX TUBES	243	
	44	125-600	S/SX 0950	S/SX Series TUBES	241	
	46	50-400	HC 46	MASTER Series	150	
	46	50-400	HT 46	MASTER TUBES	218	
	46	125-600	S/SX 0950	S/SX Series	264	
	50-58 mm	50	50-250	CT 1555	CoverTrax	202
52		102	CF 115	CONDUFLEX TUBES	242	
53		109	MF 110.1	MOBIFLEX TUBES	243	
54		80	MF 080.2	MOBIFLEX TUBES	243	
54.5		77-349	MT 0950	M Series TUBES	228	
58		100-500	KC 0900	K Series	134	
58		81-561	KE 0900	K Series	134	
58		100-600	LS/LSX 1050	LS/LSX Series	256	
58		100-600	MC 0950	M Series	160	
58		45-557	ME 0950	M Series	160	
58		45-557	MK 0950	M Series	161	
58		50-600	Q 080	QUANTUM	188	
60-73 mm		60	75-600	LC 60	MASTER Series	150
		60	53-600	LT 60	MASTER TUBES	219
	68.5	103-359	MT 1250	M Series TUBES	228	
	69	130-800	S/SX 1250	S/SX Series TUBES	241	
	70	100	CF 120	CONDUFLEX TUBES	242	
	72	162	CF 175	CONDUFLEX TUBES	242	
	72	100-800	MC 1250	M Series	160	
	72	71-551	ME 1250	M Series	160	
	72	170	MF 170.1	MOBIFLEX TUBES	243	
	72	71-551	MK 1250	M Series	161	
	72	70-600	Q 100	QUANTUM	188	
	72	130-800	S/SX 1250	S/SX Series	264	
	73	109	MF 110.2	MOBIFLEX TUBES	243	
	78-108 mm	78	80	MF 080.3	MOBIFLEX TUBES	243
80		100-800	LC 80	MASTER Series	150	
80		100-800	LT 80	MASTER TUBES	219	
87		100-800	MC 1300	M Series	160	
87		100-800	MT 1300	M Series TUBES	229	
102		170	MF 170.2	MOBIFLEX TUBES	243	
104		250-1000	S/SX 1800	S/SX Series TUBES	241	
105		200-1000	XLT 1650	XL Series TUBES	237	
108		109	MF 110.3	MOBIFLEX TUBES	243	
108		180-1000	S/SX 1800	S/SX Series	264	
108		200-1000	XLC 1650	XL Series	182	
150-370 mm		150	150-1000	S/SX 5000	S/SX Series	265
		167	170	MF 170.3	MOBIFLEX TUBES	243
	183	250-1200	S/SX 2500	S/SX Series	265	
	220	250-1500	S/SX 3200	S/SX Series	265	
	240	200-1200	S/SX 6000	S/SX Series	265	
	370	300-1500	S/SX 7000	S/SX Series	265	

Selection of the cable carrier

Step by step to the suitable cable carrier

Unsupported arrangements are used in most applications. Here, the driver connection of the cable carrier is fastened to the movable part of the plant and moves with it in a horizontal plane. The upper trough of the cable carrier does not have any sag worth mentioning and moves freely above the feed guide or the lower trough.

The steps necessary for designing a cable carrier for unsupported arrangements are shown in the following points.

Possible other movement sequences and arrangements can be found from page 309 onwards. When designing a cable carrier for these arrangements, other design parameters must be taken into consideration.

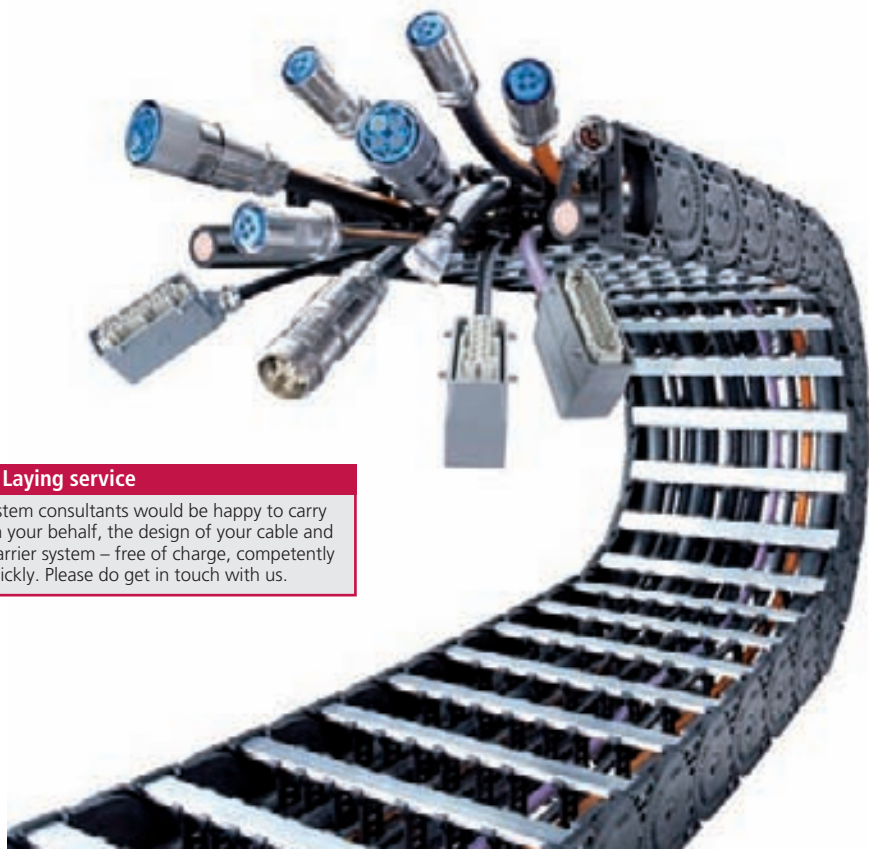
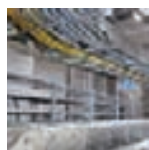

Note: Laying service

Our system consultants would be happy to carry out, on your behalf, the design of your cable and hose carrier system – free of charge, competently and quickly. Please do get in touch with us.

An overview of the 5 most important design steps for unsupported applications

Detailed data can be found on the following pages. Depending on the ambient conditions, a decision must first be made as to whether a cable carrier system of steel or plastic should be used.

1

Determining the inner dimensions

taking into account the cables and hoses to be laid and the available installation space.

Covered cable carrier?

Check whether, owing to the ambient influences, a covered cable carrier should be used.

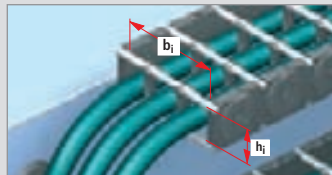

2

Determining the bend radius

The bend radius depends on the cables used. Here, the specifications of the cable manufacturer must be taken into account.

We recommend the use of KABELSCHLEPP LIFE-LINE cables that have been specially designed for use in cable carriers.

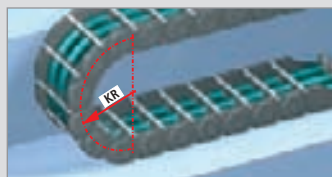

3

Selection of the product line and type

From our product overview, select the cable carrier suitable for your application, taking the application area, the size and the travel speed into consideration.



4

Calculation of the chain length

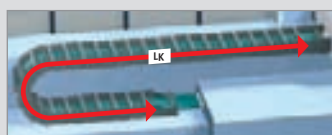

Calculation of the connection height

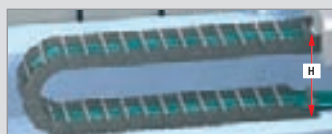

5

Checking the permissible unsupported length and if applicable, the further procedure

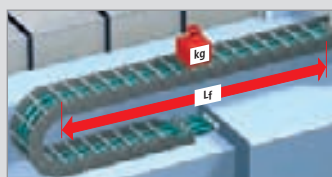

Selection of the cable carrier

1 Determining the inner dimensions

The number, type and diameter of the cables to be laid determine the inner dimensions and the inner distribution of the cable carrier

The space required by the cables and hoses can be calculated taking into consideration the following design instructions. The installation conditions give the required clear height and the inside width of the cable carrier.

The cables and hoses must be able to move freely inside the cable carrier. The following are the guide values for the dimensions of the required free space:

- for round cables:** 10 % of the cable diameter
- for flat cables:** 10 % of the cable width/cable thickness
- for hoses:** 20 % of the hose diameter

Cables lying next to each other with greatly differing diameters should be separated by dividers.

Cables of greatly differing diameters laying immediately next to each other must be avoided.

If laying several cables without separators is unavoidable, care should be taken that the remaining free passage height is lower than the smallest cable diameter. Only thus can the cables be prevented from getting wrapped around one another.

In case of multi-layer laying, we recommend providing a height separation between the individual layers.

Custom-made hole stays or separation by means of dividers prevent cables lying next to each other from rubbing against each other. In many cases, laying every cable in a separate chamber is advantageous.

A height separation must always be provided between flat cables stacked in several layers.

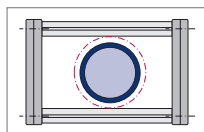

! Basically, only such cables should be used, as are suitable for use in cable carriers, such as e.g. KABELSCHLEPP LIFE-LINE cables.

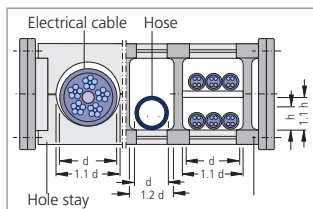
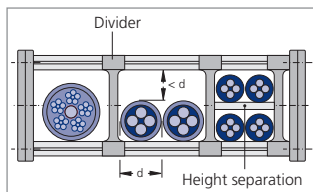

Pressure hoses lengthen or shorten under changing pressure stresses!

Shortening or lengthening of the hoses can only be compensated in the chain bend. Here, too, the calculated clear space must be retained.

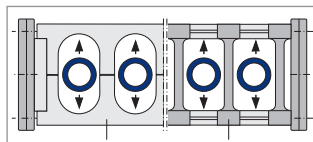

Weight distribution in case of cable laying

When laying the cables, please ensure that the cable weight is distributed symmetrically across the width of the cable carrier. The maximum life of the cable carrier can be achieved by uniform loading.

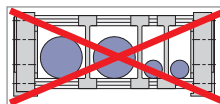

■ Unfavorable weight distribution

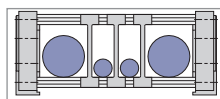

■ Favorable weight distribution

Is a covered cable carrier (TUBE SERIES) necessary?

In case of applications subject to machining chips or serious contamination, covered or closed cable carriers of the TUBE SERIES should be used.



2 Calculation of the bend radius

The bend radius is determined by two factors:

1. The largest permissible bend radius of the cables gives the smallest permissible bend radius of the cable carrier (in case of a smaller bend radius, the cables would be bent to an impermissible extent). Generally, the thickest or the stiffest cable to be carried determines the largest permissible minimum bend radius.
2. The available installation space determines the possible bend radius of the cable carrier. This must be checked with the specifications of the cables.

Note: Life of cables

A greater bend radius of the cable carrier and hence a greater bend radius (than the permissible minimum bend radius) of the cables generally increases the life of the cables. Thus, if it is possible, preferably select a somewhat larger bend radius.

When using our LIFE-LINE cables, in many cases, a smaller bend radius can be selected.

Basically, it must be ensured that the cables can take the bend radius KR without any force being necessary.

They must be able to move freely in the longitudinal direction and must not exert any tensile forces on the cable carrier in the bend.

In case of multilayer laying, the cables must be drawn into the cable carrier in such a way that they have a corresponding clearance between one another even in the bend of the chain.

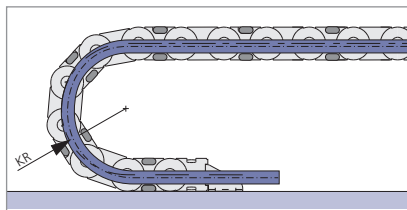

Selection of the cable carrier

3 Selection of the product line and type

BASIC-LINE Solid plastic cable carriers with fixed chain widths

Economically priced solutions for standard applications · Types with fixed or openable brackets
Many types available immediately ex-stock worldwide

MONO Cable carriers with simple design for standard applications



- Single unit chain links with the option of either fixed or openable brackets
- Simple and quick assembly
- End connector with integrated strain relief (at 0625 not illustrated)

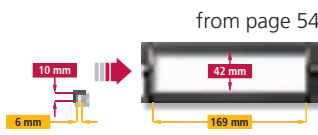

QuickTrax Compact and cost-effective cable carriers in two-component technology



- Quick and easy to open
- Crossbars in opened condition also non-switched with the chain link
- Stable chain construction
- Designs with inward or outward opening crossbars
- Long unsupported lengths

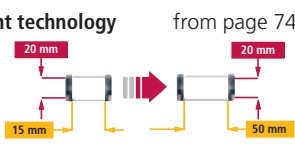

UNIFLEX Advanced Light, quiet all-rounder with wide range of applications



- Noise-optimized for quiet operation
- Inward or outward opening or single unit
- Clamp system for fast opening
- Movable or fixed dividers
- Long unsupported lengths
- Many separation options for the cables

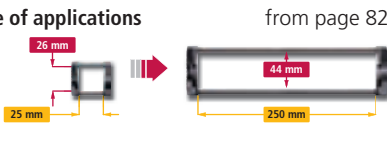

UNIFLEX Proven cable carrier with many opening and cover variants



- Openable either inwards or outwards according to design
- Robust, double stroke system for long unsupported length
- Particularly high torsional rigidity
- Open, half-covered and completely covered designs
- Many separation options for the cables

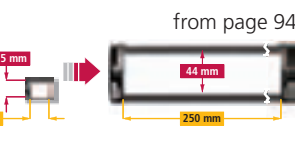

BASIC-LINE^{PLUS} Solid plastic cable carriers with fixed chain widths

Fast laying by simply pressing in the cables · Ideal for short travel paths and high travel speeds

EasyTrax Extremely quick cable laying, extra-stable thanks to two-component technology



- Very fast cable laying by simply pressing in
- Stable chain construction
- Extensive unsupported length
- Very quiet thanks to integrated noise damping system
- High travel speed possible



PROTUM Small, light cable carrier for unsupported applications



- Very long life – no hinges and hence no hinge wear
 - Very good ratio of usable space to outer dimensions
 - Low vibration and quiet operation
 - Optimum for short travel lengths and high travel speeds
- PROTUM Office:** Flexible cable carrier for office and workshop furniture

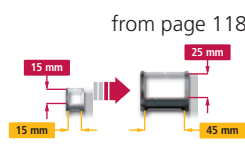

PROfile® Cable carrier for short travel lengths and high travel speeds



- Optimum for short travel lengths and high travel speeds
 - Low vibration and quiet operation
 - Very long service life
 - Tested for several million travel cycles
 - Clean-room compatible owing to low-wear construction and the concomitant minimal particle emission
 - Standard modules for cable diameters 6 – 30 mm
- from page 124

VARIO-LINE Cable carriers with variable chain widths



Aluminium or plastic stays · Aluminium stays in 1 mm width sections are available · Inside and outside easy and quick to open · Light, robust or link-free series – a suitable solution for every application

K Series Cost-effective, robust cable carrier also suitable for large additional loads



- Robust, simple construction, even with large additional loads
- Optional glide discs for applications where the carrier is rotated through 90°
- Injection molded glide runners

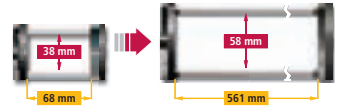

from page 132

MASTER Series Quiet and weight-optimized cable carriers



- Light design with weight-optimized sideband construction
- Excellent relationship between inside and outside height
- Customized bend radii can be supplied

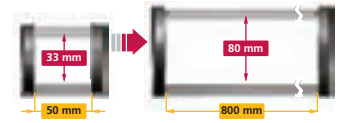

from page 148

M Series Multivariable cable carrier with extensive accessories and stay variants



- The robust all-rounder, various separation options, large selection of stay systems
- Ideal for fast, gliding applications: Replaceable glide shoes made of highly wear-resistant special plastic

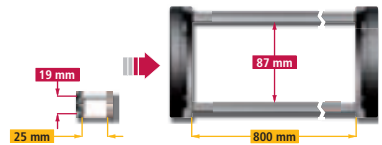

from page 158

XL Series Cable carrier with large inside height



- Large dimensions for cables with large cable diameter
- For unsupported and gliding applications
- Replaceable glide shoes made of highly wear-resistant special plastic

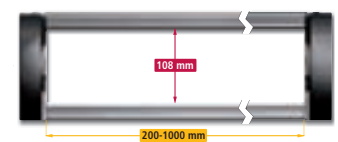

from page 180

QUANTUM Light, quiet, low-vibration for high speeds and accelerations



- **Suitable for clean rooms:** Clean room certification "Class 1" possible – no hinges, no link wear**
- Extremely quiet, 31 db (A)*
- For high accelerations up to 300 m/s²
- For travel speeds up to 40 m/s
- Long service life – no link wear at pin-hole joints
- Flexible design for 3D movements: the driver connection can move sideways and can be turned through up to ± 30 degrees
- Link-free: extruded sidebands

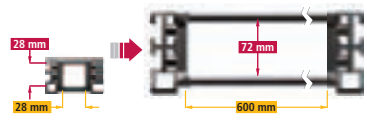

from page 186

* Tested: Q060.100.100 by TÜV Rheinland. The measurement area sound pressure level was measured at a distance of 0.5 m for uniform and jerky movement.

** Tested: Q040.77.RE-70-1000 by the Fraunhofer Institute, travel speed V1 = 0.2 m/s and V2 = 0.9 m/s

TKR 0200 Extremely quiet and low-vibration for highly dynamic applications



- Extremely quiet and low-vibration operation
- Long service life
- Ideal for highly dynamic applications
- High lateral stability
- Suitable for clean rooms
- Can be open on the inside and outside easily and quickly
- Simple shortening and extension due to modular design

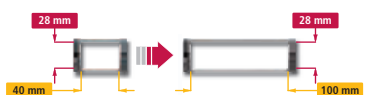

from page 194

Selection of the cable carrier

3 Selection of the product line and type

TUBE SERIES Covered cable carriers

Covered types with plastic or aluminium cover system as well as completely closed cable carriers - Protection of the cables for applications where chips or severe contamination occur

CoverTrax Extreme cable protection in harsh environmental conditions



- Solid plastic
- Outstanding protection of the cables
- Large unsupported length
- Very quiet thanks to internal noise damping system
- For unsupported and gliding arrangements
- Various or fixed divider systems
- Integrated strain relief devices possible in the UMB-connection

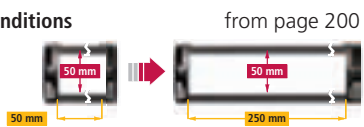

from page 200

UNIFLEX TUBES Proven solid cable carriers with fixed carrier width



- Solid plastic
- Easy to open
- Robust, double stroke system for long unsupported lengths
- Particularly high torsional rigidity
- End connectors with integrated strain relief
- Economically priced standard types

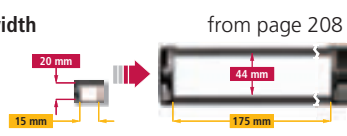

from page 208

MASTER TUBES Quiet and weight-optimized cable carriers



- Extremely quiet due to internal noise damping system
- Favorable ratio of inner to outer dimensions
- Standard bend radii, application-specific intermediate radii on request
- Variable pretension for many different applications possible
- Can be opened quickly on the inside and outside for cable laying
- Wide range of options for internal subdivision

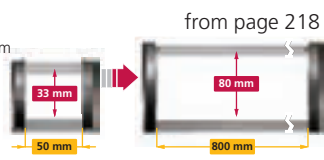

from page 218

MT Series Multivariable cable carrier with extensive accessories



- Aluminium cover system or plastic cover system available
- Can be opened quickly on the inside and the outside for cable laying
- Extremely robust due to stable plate construction
- Enclosed stroke system not sensitive to dirt/contamination
- Many possibilities of inner subdivision
- Highly wear-resistant, replaceable glide shoes available

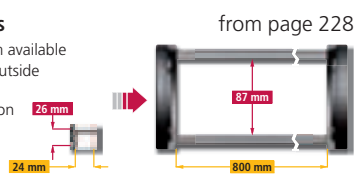

from page 228

XLT Series Cable carriers with large inside height



- Large dimensions
- Can be quickly opened on the inside and outside for cable laying
- Highly wear-resistant, replaceable glide shoes available
- Different connection variants
- Different ways of separating the cables
- Optionally with strain relief

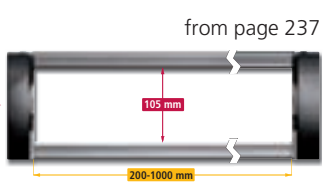

from page 237

S/SX Series Extremely robust and stable steel chains



- Available in 1 mm section widths
- Extremely robust stable steel chains for heavy mechanical loads and harsh environmental conditions
- Long unsupported lengths also for large additional loads
- Various types available in different dimensions
- Link design with special bolts for a long service life

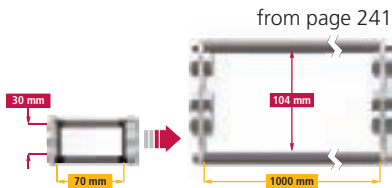

CONDUFLEX Closed designer cable carrier



- Attractive appearance owing to high-grade steel brackets and fiberglass reinforced polyamide frame
- Very well sealed design
- With protective straps ideal for hot chips
- Quiet operation due to small pitch
- Easy replacement of the crossbars in the case of external damage is possible
- Easy to shorten or extend at a later date

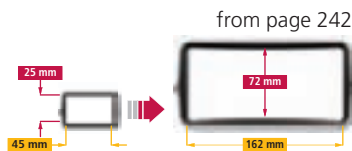

MOBIFLEX Enclosed cable carrier with flexible metal helical tube



- Very well sealed design
- Ideal in case of hot metal chips
- Unsupported thanks to the inserted, pre-tensioned steel band

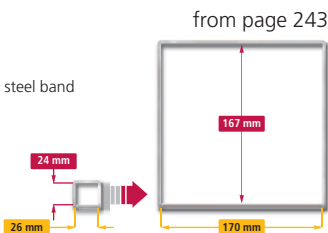

3D-LINE Cable carriers for 3D-movements

Ideal for use on jointed and swivel arm robots - Easy laying by simply pressing in the cables
With channel system, it is a universal solution for rotary applications

ROBOTRAX Cable carriers for 3D movements



- For three-dimensional movements
- Open design
 - Fast cable laying by simple pressing in of the cables - no threading through is necessary
 - Simple inspection of all the cables
- Can be deployed on robots for swiveling and rotational movements:
 - The same system for robot feet and arms
- Optimum system for long service life of the cables:
 - The minimum bend radius can be maintained
 - The cables are cleanly isolated in three separate chambers
- Special plastic for long service life
- With channel system, it is a universal solution for rotary applications such as rotary tables and assembly equipment

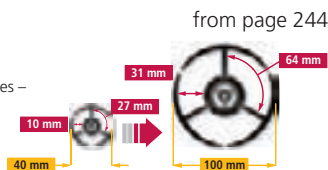

Selection of the cable carrier

3 Selection of the product line and type

STEEL-LINE Steel cable carriers – solutions for extreme applications

Robust design for heavy mechanical loads - High additional loads and long unsupported lengths possible
Best suited for extreme and particular environmental influences – heat resistant

LS/LSX Series Cost-effective steel chains with light design



- Available in 1 mm width sections
- Improved, dynamic characteristic values due to weight-optimized design
- 40 % lighter than S 0950 with RS stay variant
- Long unsupported lengths for small to medium additional loads
- Chain belts made of specially coated steel or stainless steel
- Optional central bolt for applications with large loads
- A cover with steel band for protecting the cables is available on request

from page 254

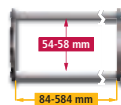

S/SX Series Extremely robust and stable steel chains



- Available in 1 mm width sections
- Extremely robust and stable steel chains for heavy mechanical loads and harsh environmental conditions
- Very long unsupported lengths also for large additional loads
- Joint design with special bolts for a long service life
- Proven design with chain belts made of galvanized steel or stainless steel
- Various types available in different dimensions
- Covers with aluminium cover system or steel strip possible for protection of the cables

from page 262



CONDUFLEX Closed designer cable carrier



- Very well sealed design
- With protective straps ideal for hot chips
- High-grade steel brackets and fiberglass-reinforced polyamide frames
- Easy to shorten or extend at a later date

from page 282

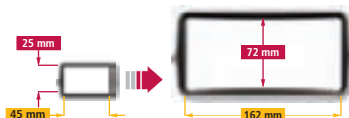

MOBIFLEX Enclosed cable carrier with flexible metal helical tube



- Very well sealed design
- Ideal for hot metal chips
- Flexible metal helical tubes combined with special steel band
- Unsupported thanks to the inserted, pre-tensioned steel band

from page 288

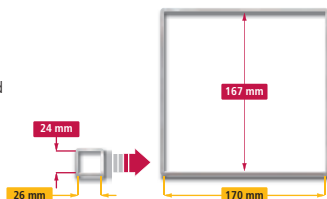

Selection of the cable carrier

4 Calculation of the chain length and the connection height

Definition

In the case of a unsupported arrangement, the driver connection of the cable carrier is fastened to the movable part of the plant and moves with it in the horizontal direction.

The upper trough of the cable carrier does not have any sag worth mentioning and moves freely above the feed guide or the lower trough.



Calculation of the chain length

We recommend placing the fixed-point connection in the middle of the travel length. This gives the shortest connection between the fixed and movable driver point and hence the most economical chain length and cable length!

Fixed point in the middle of the travel path L_S :

Chain length L_k

$$L_k \approx \frac{L_S}{2} + L_B$$

Chain length L_k
rounded off to pitch t

Unsupported length L_f

$$L_f \approx \frac{L_S}{2} + (1 \dots 3) \times t$$

L_S = Maximum travel length
of the application

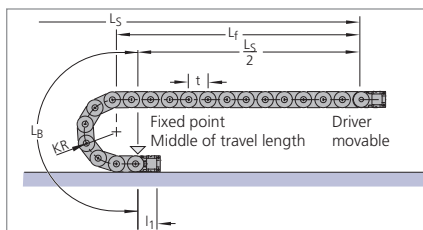

Fixed point outside the middle of the travel path L_S :

Chain length L_k

$$L_k \approx \frac{L_S}{2} + L_B + L_V$$

Chain length L_k
rounded off to pitch t

Please take into
consideration the greater
unsupported length L_f !

L_V = Longitudinal offsets
between cable carrier
fixed point center of the
travel length

L_S = Maximum travel length
of the application

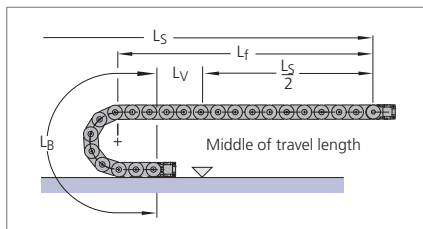

Calculation of the bend length

Bend length L_B

Plastic cable carriers:

$$L_B = KR \times \pi + 2 \times t$$

Steel cable carriers:

$$L_B = KR \times \pi + 4 \times t$$

QUANTUM:

$$L_B = KR \times \pi + 12 \times t$$

TKR 0200:

$$L_B = KR \times \pi + 4 \times t$$

PROFILE, CONDUFLEX:

$$L_B = KR \times \pi + 9 \times t$$

MOBIFLEX:

$$L_B = KR \times \pi + KR$$

Selection of the cable carrier

4 Calculation of the chain length and the connection height

Calculation of the connection height

Connection height H

Plastic cable carriers*:	$H = 2 KR + h_G$
MC 1300:	$H = 2 KR + 1.5 h_G$
QUANTUM:	$H = 2 KR + \frac{4}{3} h_G$
TKR 0200:	$H = 2 KR + 40 \text{ mm}$
PROFILE:	$h_G = h_M$
Steel cable carriers:	$H = 2 KR + 1.5 h_G$

* except MC 1300

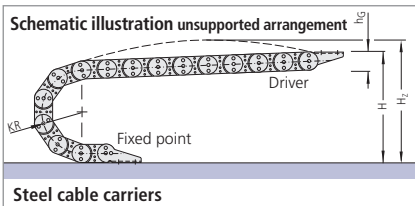
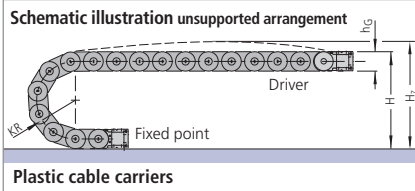

Pretensioning and required installation height Hz

To achieve a long unsupported length, KABELSCHLEPP cable carriers are made with pre-tensioning in the standard version. The pre-tensioning effects an elevation of the upper trough in the zone of the unsupported length. Please take the pre-tensioning into consideration when determining the required passage height Hz.



■ Cable carrier with additional load (cables and hoses)



■ Cable carrier without additional load

UMB (Universal Mounting Brackets)

Universal mounting brackets for connecting above, below or at the front.



Selection of the cable carrier

5 Checking the permissible unsupported length

The load diagram marks the area of the unsupported length L_f , in which the cable carrier does not have any sag worth mentioning. If a greater additional load or a longer travel path is selected, the upper trough begins to sag (see below: Horizontal unsupported arrangement with permissible, desired sag).

The specified load diagrams are applicable to an average intrinsic chain weight (average chain width). Please note that with particularly large chain widths or when cover systems are used, a larger intrinsic chain weight and hence a smaller possible additional load is obtained. The following pages show an overview of the load diagrams of our cable carriers.

Detailed specifications can be found under the respective chain type.

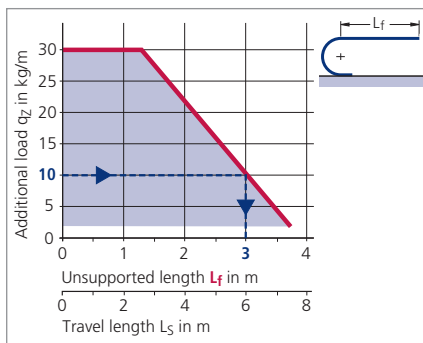

Example: With an additional load of 10 kg the maximum unsupported length L_f is 3 m.

Further procedure, if the unsupported length determined in the load diagram is exceeded*

Accept the sag of the upper trough

By definition, the unsupported length L_f is the length at which the upper trough of the cable carrier does not show any sag worth mentioning. In case of a longer arrangement, or greater additional loads, the upper trough of the cable carrier sags. The cause of this is the elasticity of the material. Proper working of the cable carrier system continues to be guaranteed. Such an arrangement is called a horizontal unsupported arrangement with permissible sag.

The length with permitted sag is designated as L_D . It is somewhat greater than the unsupported length L_f .

Please ask us about the corresponding values. We would be happy to advise you.

Please note that with this arrangement, no projecting plant parts should get run over. Maximum possible speed and acceleration are somewhat lower than with arrangements without sag.

Alternatively, there is the option:

- To select a bigger cable carrier system
- To allow a cable carrier to "slide in a guide channel" (see guide channels)
- To use a steel cable carrier

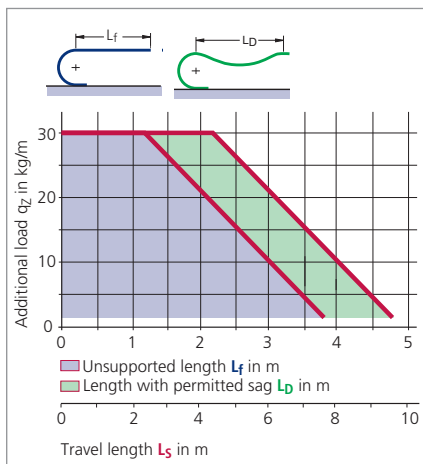

* only cable carriers made of plastic

Load diagrams for unsupported applications

BASIC-LINE

MONO

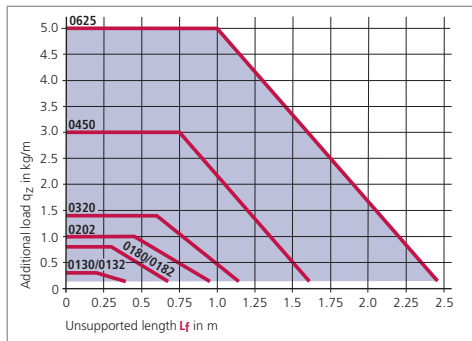

QuickTrax

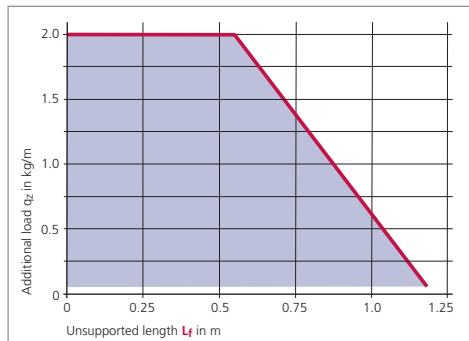

UNIFLEX

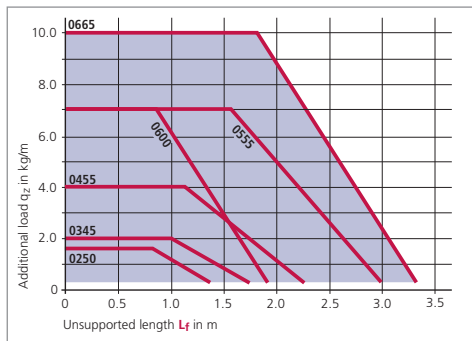

UNIFLEX *Advanced*

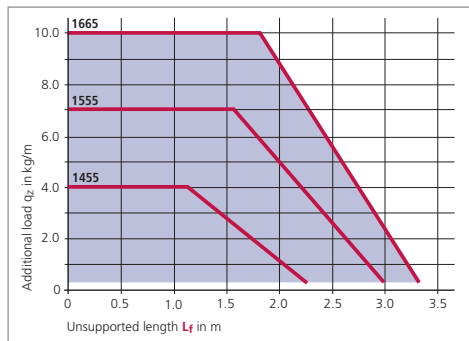

BASIC-LINE^{PLUS}

EasyTrax

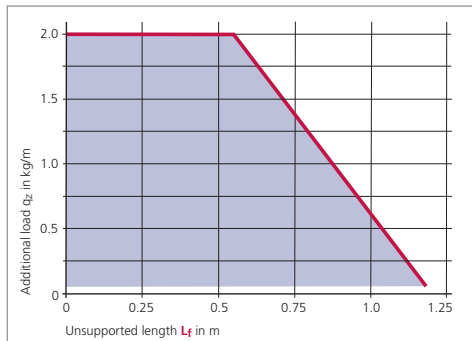

PROTUM

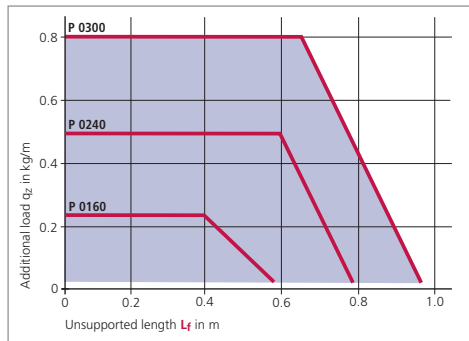

VARIO-LINE

K Series

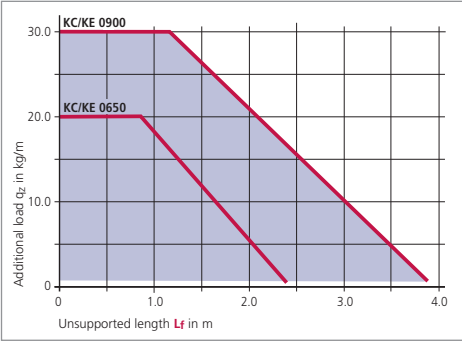

MASTER Series

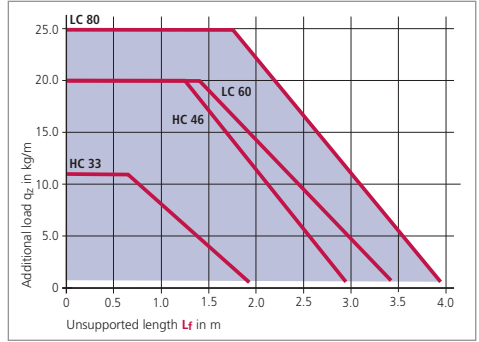

M Series

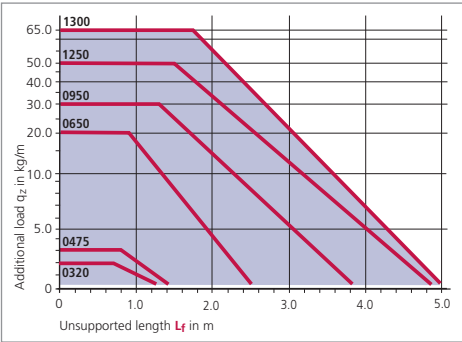

XL Series

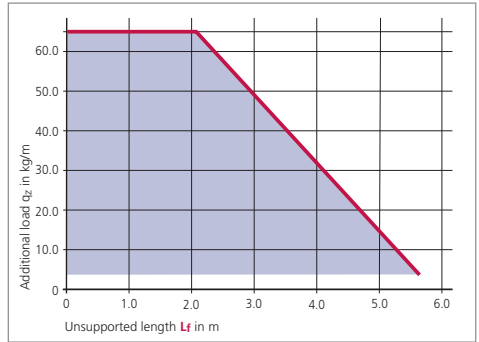

QUANTUM

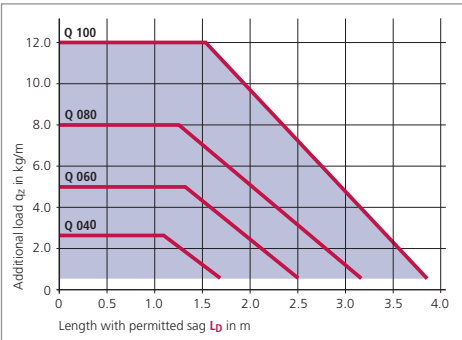

TKR 0200

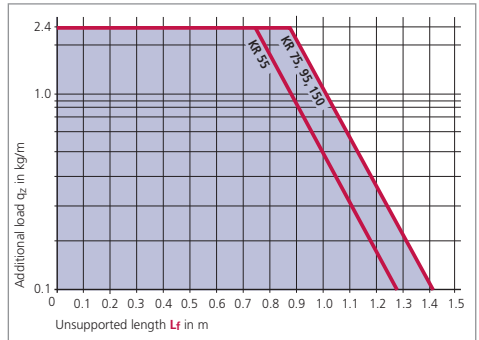

Load diagrams for unsupported applications

TUBE-SERIES

CoverTrax



UNIFLEX TUBES

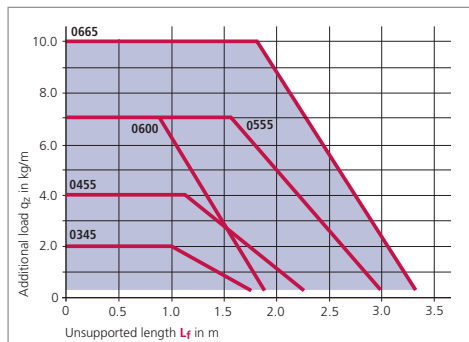

MASTER TUBES

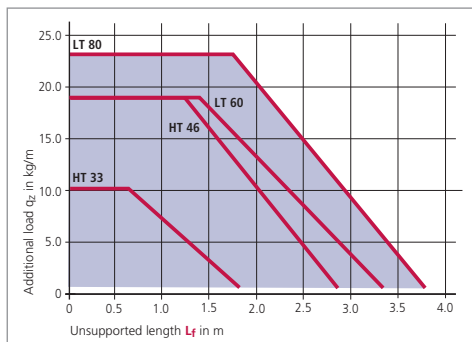

MT SERIES

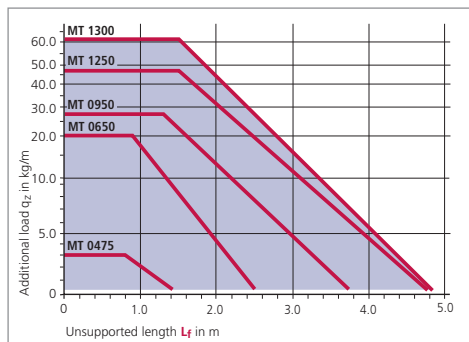

XLT Series

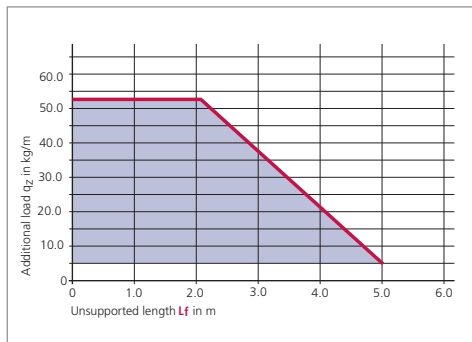

STEEL-LINE

LS/LSX 1050

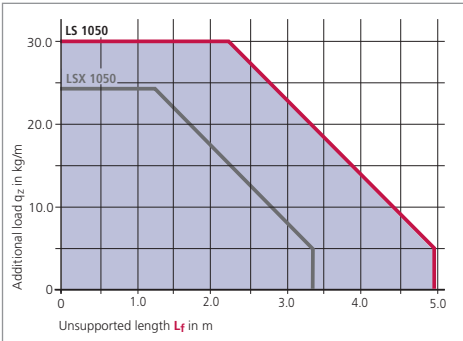

S/SX 0650, 0950, 1250, 1800

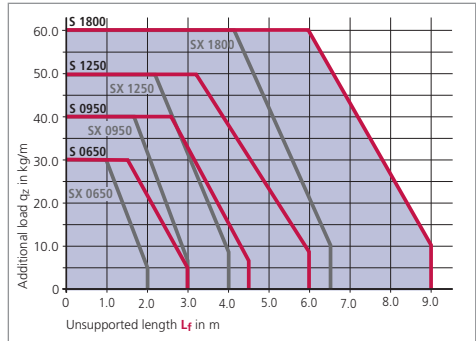

S/SX 2500, 3200

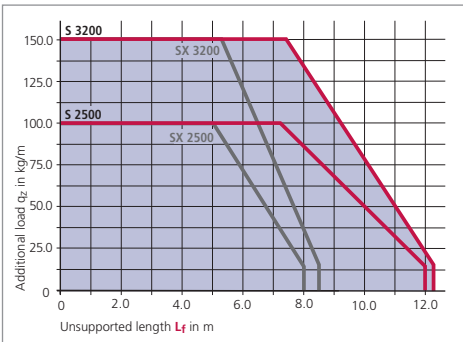

S/SX 5000, 6000, 7000

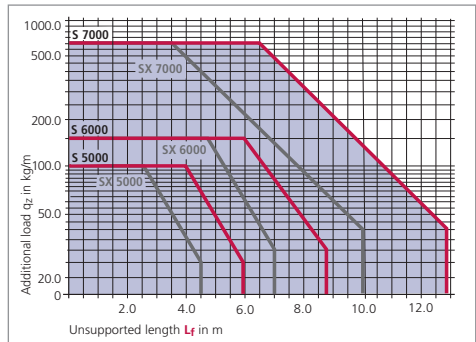

CONDUFLEX

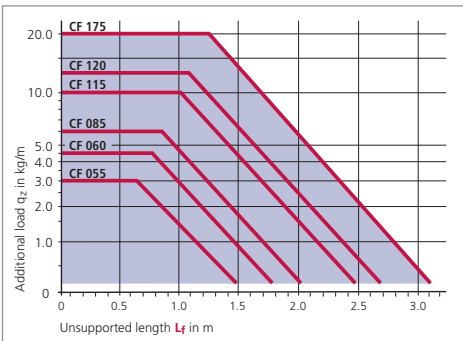

MOBIFLEX

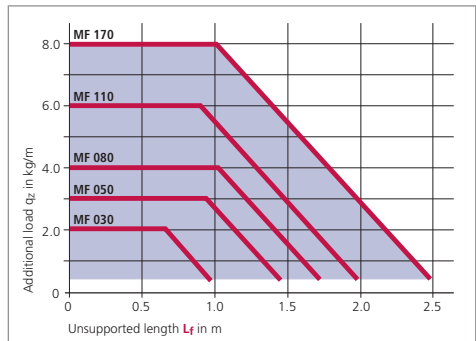

Long service life of the cables

Frame stays made of aluminium

Low jacket wear is an essential requirement for a long service life of the cables in the cable and hose carrier system. As well as the jacket material, the stay material as cable support is also responsible for the jacket wear.

We have examined the wear of different cables depending on the stay material in extensive series of tests.

Thereby, already existing test results have been confirmed several times. Aluminium as a support is very gentle on the sheathing of cables. This result is independent of the cable manufacturer and applies to the most common jacket materials.

As well as the good abrasion index, aluminium is particularly suitable as stay material due to its **high strength for a low intrinsic weight**. Chain widths up to 1000 mm can be achieved without the chain being particularly stressed due to additional weight.

TIP: Jacket wear on aluminium stays

The jacket wear test shows up to 13 times greater jacket wear of PVC cables on plastic stays as compared with aluminium stays.

Save costs due to low jacket wear for cables

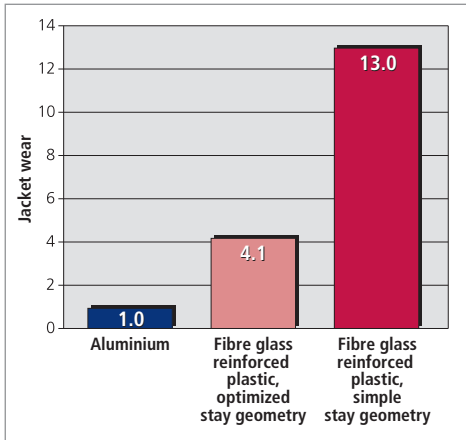

■ Jacket wear of PVC cables against stays scaled against aluminium



Cable carriers made of special materials

For special ambient conditions, there are cable carriers made of special materials available. Please do get in touch with us, we would be happy to advise you.

High-temperature-resistant cable carriers

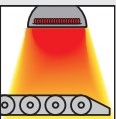

Cold storage resistant cable carriers



Ex-protected cable carriers

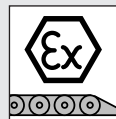

ESD cable carriers



2-shot-technology

Component 1: flexible – quick cable laying

Component 2: very stable – large unsupported length

The 2-shot-technology of our new cable carriers makes it possible to unite seemingly non-integral characteristics: **Ruggedness and Flexibility.**

Cable carriers should be very rugged and have an extensive supporting length. At the same time they should afford quick and easy set-up.

The new cable carriers **EasyTrax** and **QuickTrax** unite these qualities through an innovative design and the materials combination of hard chain elements made of fiberglass reinforced material with lamella crossbars or film hinges made of specially formulated flexible synthetics/plastics.



EasyTrax 0320

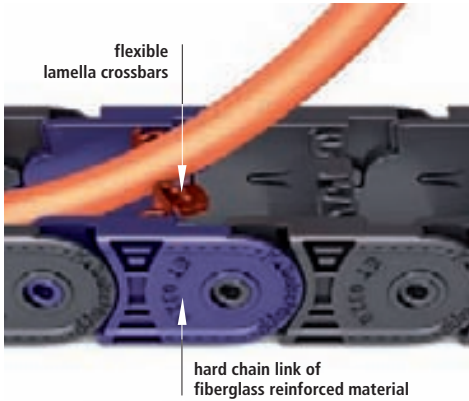

QuickTrax 0320

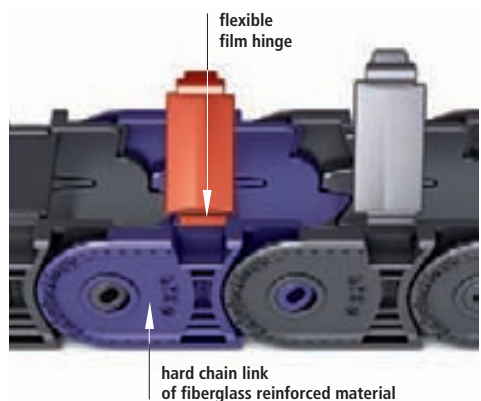

■ Cables can be pushed in quickly and easily thanks to flexible swivel joint

■ Hand opening – opening and closing even without tools.

Conductive ESD cable carriers

Electrostatic discharges (ESD) represent a hazard for the manufacture and processing of electronic components. They cannot be processed without suitable protection. The requirements for materials, tools and thus also cable carriers are defined by the ESD standard DIN EN 61340.

Our proven ESD cable carriers, which are manufactured from our KS-PA/ESD material, meet the requirements of the ESD standards with regard to discharge capability and resistance behavior.

The increasing miniaturization of semiconductor components is leading to greater vulnerability to ESD, and thus to the need for improved ESD protection.

This necessitates a lower surface resistance of the plastic cable carriers used in handling and assembly.

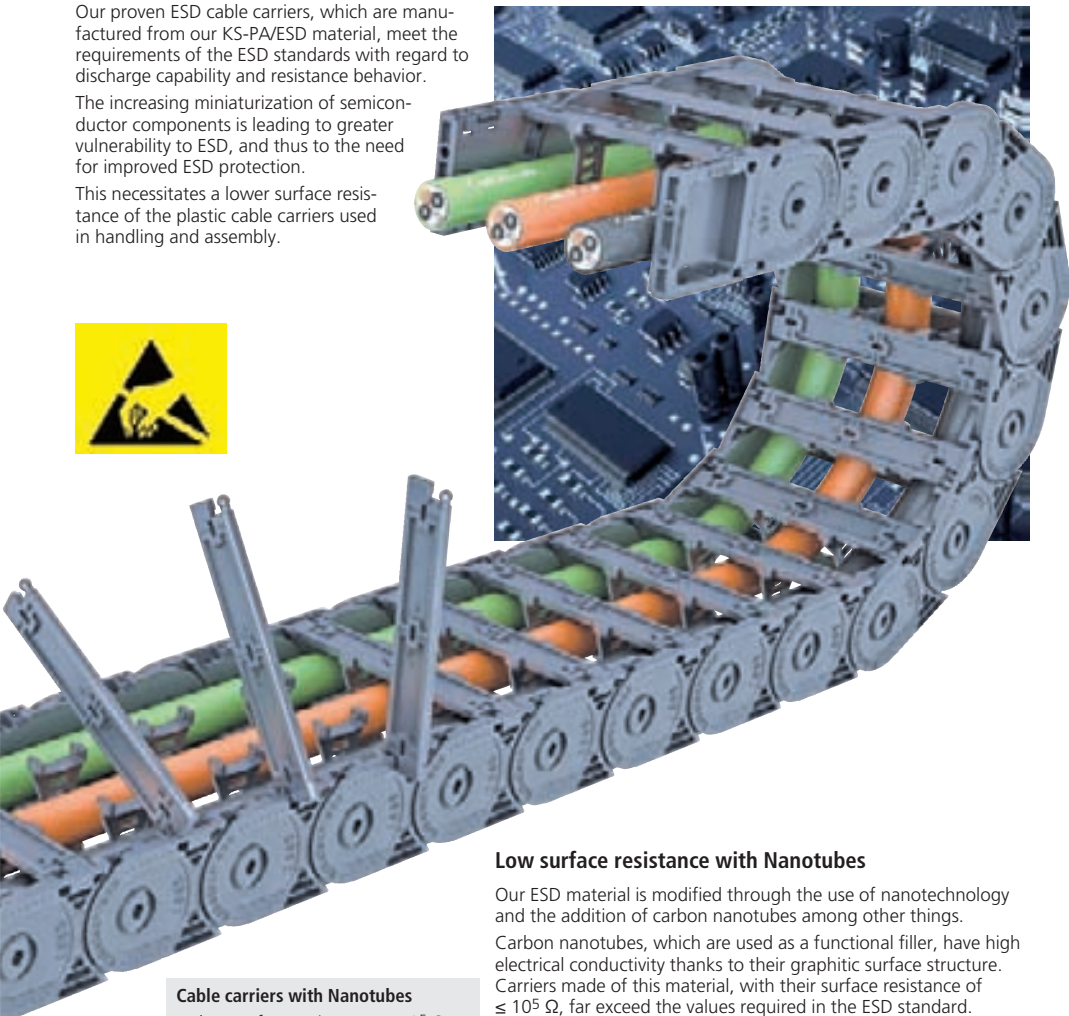

Low surface resistance with Nanotubes

Our ESD material is modified through the use of nanotechnology and the addition of carbon nanotubes among other things.

Carbon nanotubes, which are used as a functional filler, have high electrical conductivity thanks to their graphitic surface structure. Carriers made of this material, with their surface resistance of $\leq 10^5 \Omega$, far exceed the values required in the ESD standard.

Carbon nanotubes have a diameter of a few nanometers and a length of up to several micro-meters.

Cable carriers with Nanotubes

- low surface resistance: $\leq 10^5 \Omega$
- significantly exceed the values required by the ESD standard
- areas of application: Chip handling, semiconductor production, electronics production, solar technology

Quality with a test report

Each ESD cable carrier with Nanotubes technology comes with a KABELSCHLEPP test report.

Werkzeugzeugnis		Werkzeugzeugnis	Werkzeugzeugnis
Werkzeugzeugnis Bauzeichnung 2.2 nach DIN EN 10204 Teilform 2.2 (Anhang A) DIN EN 10204		Bezeichnung: Flach-Flachschlepp Bestell-Nr.: 180000 Zeichnung-Nr.: 1432100	Material: Alu Bestell-Nr.: 180000 Zeichnung-Nr.: 1432100
Hersteller: Müllerwerke GmbH Am Schloßgraben 97124 Mühlhausen		Hersteller: Flach-Flachschlepp Am Schloßgraben 97124 Mühlhausen	
Bezeichnung: Flach-Flachschlepp Material: Alu Bestell-Nr.: 180000 Zeichnung-Nr.: 1432100		Bezeichnung: Flach-Flachschlepp Material: Alu Bestell-Nr.: 180000 Zeichnung-Nr.: 1432100	
Werkzeugzeugnis Werkzeugeigenschaften Werkzeugeigenschaften Werkzeugeigenschaften Werkzeugeigenschaften		Werkzeugzeugnis Werkzeugeigenschaften Werkzeugeigenschaften Werkzeugeigenschaften Werkzeugeigenschaften	
1	Überschneidungswinkel	60 ° ± 2	
2	Anzahl Rollenglieder	30	

Higher conductivity of the entire carrier

Thanks to the large specific surface and the extremely even distribution of the nanotubes in the material, a good conductivity is also achieved at the contact points between the chain links and thus over the entire length of the carrier.

Thus, with a 125 link (= 4000 mm) long KABELSCHLEPP cable carrier of type ET 0320.025.030.038 made of ESD material, a resistance of $\leq 10^5 \Omega$ was measured.

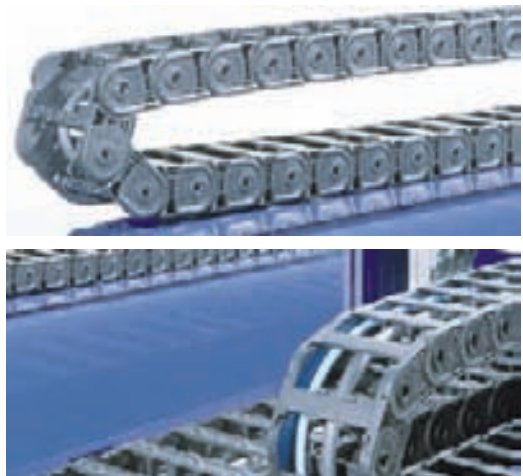

High stability

Modification of the fiberglass reinforced material with Nanotubes makes the cable carriers even more stable.

The Nanotubes have a multiple times higher tensile strength than steel, at a sixth of the weight.

This likewise increases the mechanical characteristics of cable carriers made of ESD material, while retaining high elasticity.

This effect is also used successfully in many types of sports equipment such as tennis rackets, bicycles and golf clubs.

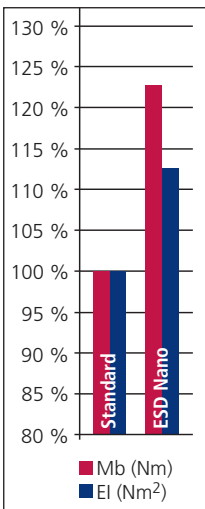

High conductance even after hundreds of thousands of motion cycles

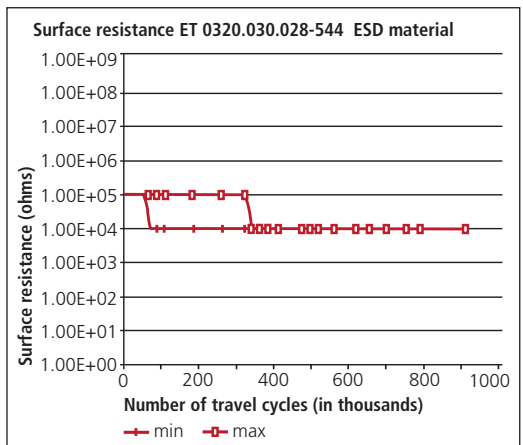

The test shows that the surface resistance of the entire cable carrier decreases during the run-off phase, and then remains constant at 10 k ohm.



BASIC-LINE

Solid plastic cable carriers with fixed chain widths

- Economically priced solutions for standard applications
- Types with fixed or openable brackets
- Many types available immediately ex-stock world wide



MONO

Cable carriers with simple design for standard applications

page 54



QuickTrax

Compact and cost-effective cable carriers in two-component technology

page 74

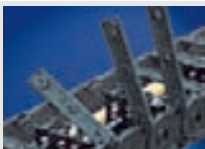

UNIFLEX *Advanced*

Light, quiet all-rounder with wide range of applications

page 82



UNIFLEX

Proven cable carrier with many opening and cover variants

page 94

MONO
The power to innovate

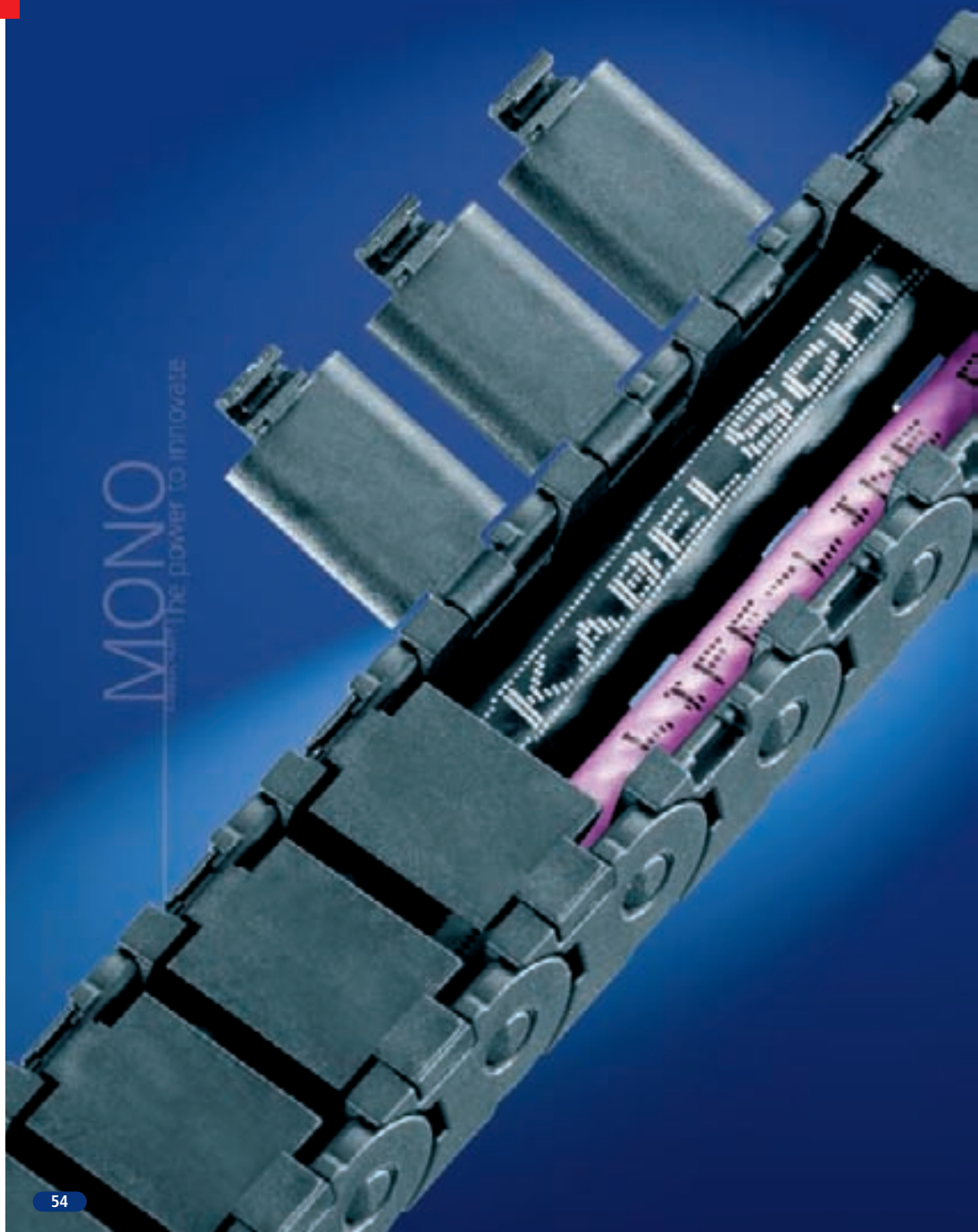

MONO

Cable carriers with simple design for standard applications*

- Cost-effective cable carrier
- Simple and quick assembly
- Almost all types available immediately ex stock all around the world
- TÜV design approved in accordance with 2PFG 1036/10.97

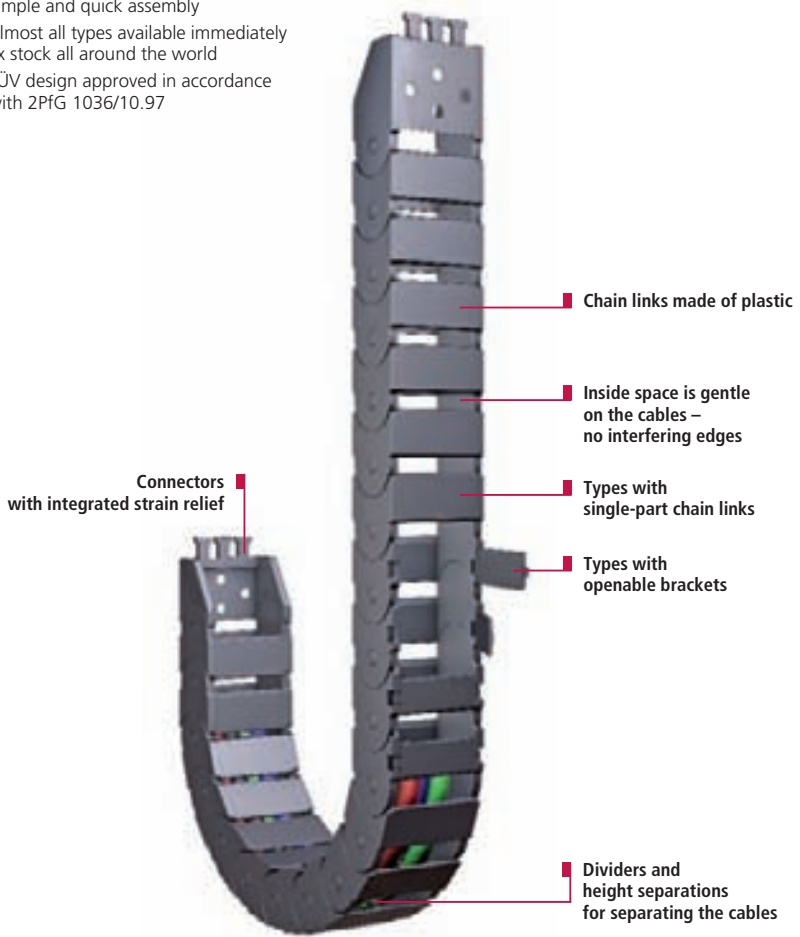

Inside heights



Inside widths



kabelschlepp.de

Fon: +49 2762 4003-0

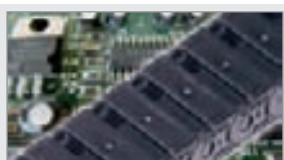

Small types for restricted installation conditions



Fast shortening/extending due to simple connection of the chain links



Different connection options by simply changing the connectors

OnlineEngineer.de
KABELSCHLEPP
Cable Carrier Configurator

Subject to change.

* Some features can be different for certain types for design reasons. Our specialists are happy to advise you.

Overview MONO

Inside heights



Inside widths



kabelschlepp.de

Fon: +49 2762 4003-0

Use our free project planning service.

Types 0130, 0180 with hinged, openable brackets



Type	h _i	B _i	Maximum travel length in m	Dynamics of unsupported arrangement		Page
				Travel speed v _{max} in m/s	Travel acceleration a _{max} in m/s ²	
0130	10	6-40	40	10	50	58
0180	15	10-40	70	10	50	60

Dimensions in mm

Types 0132, 0202, 0182 with fixed brackets



Type	h _i	B _i	Maximum travel length in m	Dynamics of unsupported arrangement		Page
				Travel speed v _{max} in m/s	Travel acceleration a _{max} in m/s ²	
0132	10	6-40	40	10	50	58
0182	15	10-40	70	10	50	60
0202	11	6-20	70	10	50	62

Dimensions in mm

Type 0320 with fixed brackets



Type	h _i	B _i	Maximum travel length in m	Dynamics of unsupported arrangement		Page
				Travel speed v _{max} in m/s	Travel acceleration a _{max} in m/s ²	
0320	19	13-37	80	10	50	64

Dimensions in mm

Overview MONO

Type 0450 with hinged, openable or fixed brackets

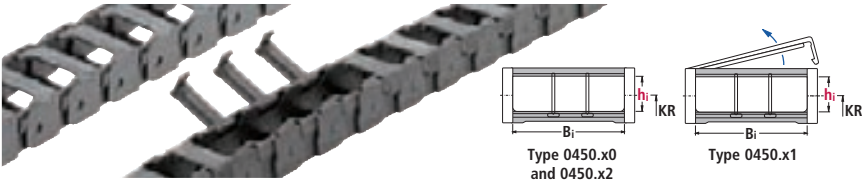

Inside heights



Inside widths



Type	h _i	B _i	Maximum travel length in m	Dynamics of unsupported arrangement		Page
				Travel speed v _{max} in m/s	Travel acceleration a _{max} in m/s ²	
0450.x0	24	38-103	120	10	50	66
0450.x1	24	38-103	120	10	50	66
0450.x2	28	38-103	120	10	50	66

Dimensions in mm

Type 0625 with hinged, openable or fixed brackets



kabelschlepp.de

Type	h _i	B _i	Maximum travel length in m	Dynamics of unsupported arrangement		Page
				Travel speed v _{max} in m/s	Travel acceleration a _{max} in m/s ²	
0625.22/40/42	34	65-108	130	8	40	70
0625.23/43	34	65-108	130	8	40	70
0625.x5	42	65-169	130	8	40	70

Font: +49 2762 4003-0

OnlineEngineer.de
 Web-Configurator
 Cable Carrier Configurator

Types 0132 and 0130

Inside height



Inside widths



Type 0132

Inside/Outside: Not to be opened

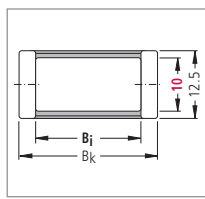
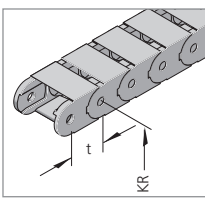

Type 0130

Outside: Hinged, openable brackets

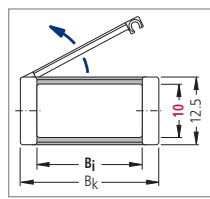
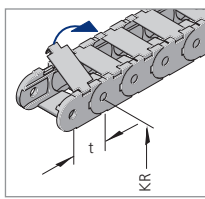

Dimensions and intrinsic chain weight

Type	h _i mm	B _i mm	B _k mm	Intrinsic chain weight kg/m
0132.06	10	6	12	0.13
0132.10	10	10	16	0.14
0132.15	10	15	21	0.15
0132.20	10	20	26	0.16
0132.30	10	30	36	0.18
0132.40	10	40	46	0.20

Type	h _i mm	B _i mm	B _k mm	Intrinsic chain weight kg/m
0130.06	10	6	12	0.13
0130.10	10	10	16	0.14
0130.15	10	15	21	0.15
0130.20	10	20	26	0.16
0130.40	10	40	46	0.20

kabelschlepp.de

Bend radius and pitch

Types 0132 and 0130

Bend radii KR mm		
20	28	37

Pitch t = 13.0 mm

Load diagram

for unsupported length L_f depending on the additional load

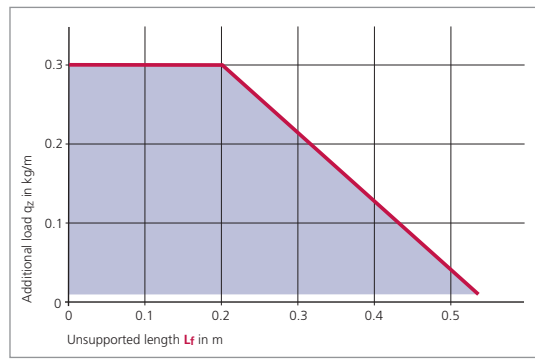

Unsupported length L_f

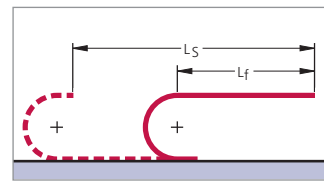

In the case of longer travel lengths, sag of the cable carriers is technically permissible depending on the application.

In a gliding arrangement, even longer travel lengths are possible (see page 295).

We are at your service to advise on these applications.

Fon: +49 2762 4003-0

Use our free project planning service.

Example of ordering

Cable carrier	0130	-	10	-	28	-	390	Connection	FA/MA
Type	Inside width B _i in mm		Bend radius KR in mm		Chain length L _k in mm (without connection)		Connection Fixed point/Driver		

Types 0132 and 0130

Connection dimensions

Plastic connectors with integrated strain relief

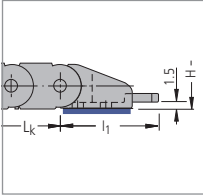

Short connectors without strain relief are also available for restricted installation conditions. Please contact us.

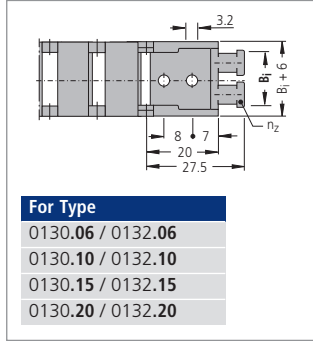

For Type
0130.06 / 0132.06
0130.10 / 0132.10
0130.15 / 0132.15
0130.20 / 0132.20

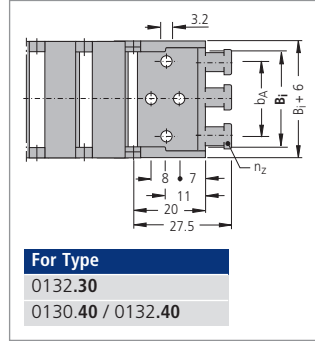

For Type
0132.30
0130.40 / 0132.40

Type	B _i mm	B _k mm	b _A mm	n _Z
0130.06 / 0132.06	6	12	–	1
0130.10 / 0132.10	10	16	–	1
0130.15 / 0132.15	15	21	–	2
0130.20 / 0132.20	20	26	–	2
0132.30	30	36	22	3
0130.40 / 0132.40	40	46	32	4

The dimensions of the fixed point and driver connections are identical.

Inside height



Inside widths



kabelschlepp.de

Fon: +49 2762 4003-0

Connection variants

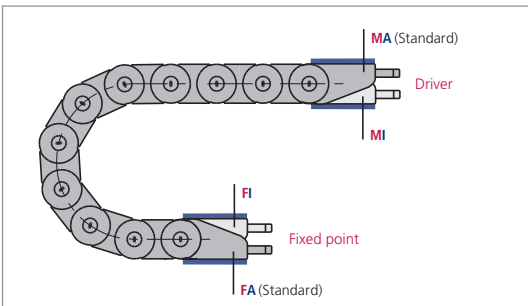

Connection point

- M – Driver
- F – Fixed point

Connection type

- A – Threaded joint outside (standard)
- I – Threaded joint inside

In the standard version, the connectors are mounted with the threaded joint outwards (FA/MA).

When ordering please specify the desired connection type (see ordering key on page 332).

The connection type can subsequently be altered simply by varying the connectors.

Types 0182 and 0180

Inside height



Inside widths



Type 0182

Inside/Outside: Not to be opened

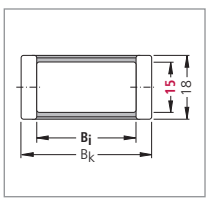
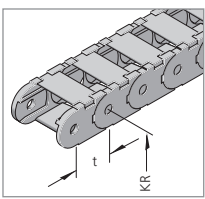

Type 0180

Outside: Hinged, openable brackets

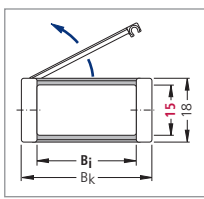
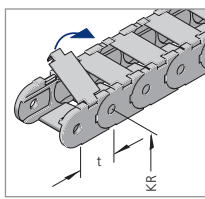

Dimensions and intrinsic chain weight

Type	h _i mm	B _i mm	B _k mm	Intrinsic chain weight kg/m
0182.10	15	10	18	0.23
0182.15	15	15	23	0.24
0182.20	15	20	28	0.25
0182.30	15	30	38	0.28
0182.40	15	40	48	0.30

Type	h _i mm	B _i mm	B _k mm	Intrinsic chain weight kg/m
0180.10	15	10	18	0.23
0180.15	15	15	23	0.24
0180.20	15	20	28	0.25
0180.30	15	30	38	0.28
0180.40	15	40	48	0.30

kabelschlepp.de

Bend radius and pitch

Types 0182 and 0180

Bend radii KR mm		
28	37	50

Pitch t = 18.0 mm

Load diagram

for unsupported length L_f depending on the additional load

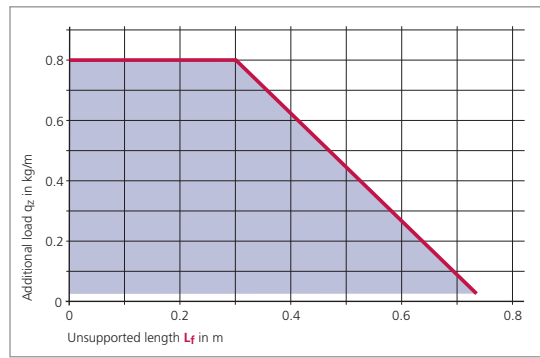

Unsupported length L_f

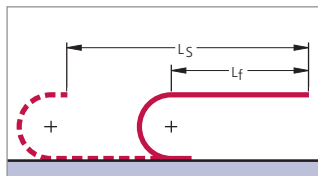

In the case of longer travel lengths, sag of the cable carriers is technically permissible depending on the application.

In a gliding arrangement, even longer travel lengths are possible (see page 295).

We are at your service to advise on these applications.

Fon: +49 2762 4003-0

Use our free project planning service.

Example of ordering

Cable carrier	0180	-	30	-	37	-	720	Connection	FA/MA
Type	Inside width B _i in mm		Bend radius KR in mm		Chain length L _k in mm (without connection)		Connection Fixed point/Driver		

Types 0182 and 0180

Connection dimensions

Plastic connectors with integrated strain relief

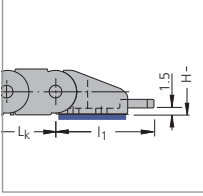

Short connectors without strain relief are also available for restricted installation conditions. Please contact us.

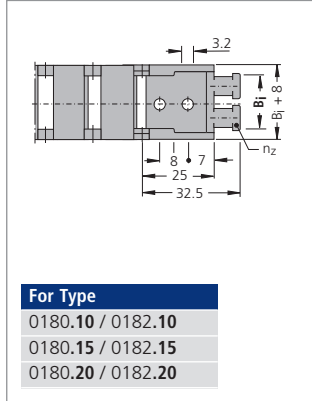

For Type
0180.10 / 0182.10
0180.15 / 0182.15
0180.20 / 0182.20

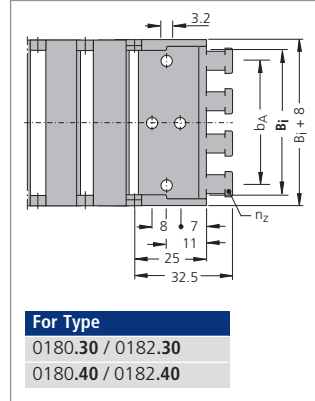

For Type
0180.30 / 0182.30
0180.40 / 0182.40

Type	B _i mm	B _k mm	b _A mm	n _Z
0180.10 / 0182.10	10	18	–	1
0180.15 / 0182.15	15	23	–	2
0180.20 / 0182.20	20	28	–	2
0180.30 / 0182.30	30	38	22	3
0180.40 / 0182.40	40	48	32	4

The dimensions of the fixed point and driver connections are identical.

Connection variants

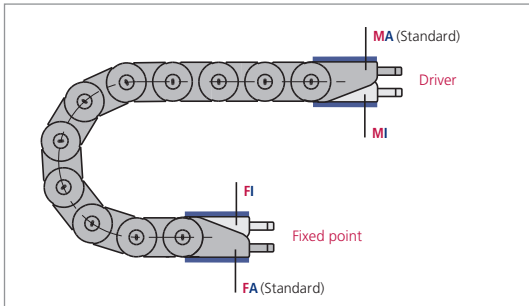

Connection point

- M** – Driver
- F** – Fixed point

Connection type

- A** – Threaded joint outside (standard)
- I** – Threaded joint inside

In the standard version, the connectors are mounted with the threaded joint outwards (**FA/MA**).

When ordering please specify the desired connection type (see ordering key on page 332).

The connection type can subsequently be altered simply by varying the connectors.

Inside height

15

Inside widths

10
40

kabelschlepp.de

Fon: +49 2762 4003-0

OnlineEngineer.de
With CableChain
Cable Chain Configurator

Type 0202

Inside/Outside: Not to be opened

Inside height



Inside widths

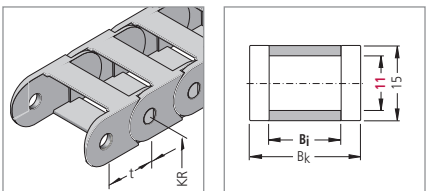

Dimensions and intrinsic chain weight

Type	h _i mm	B _i mm	B _k mm	Intrinsic chain weight kg/m
0202.06	11	6	13	0.14
0202.10	11	10	17	0.15
0202.15	11	15	22	0.16
0202.20	11	20	27	0.17

Bend radius and pitch

Bend radii KR mm			
18	28	38	50

Pitch t = 20.0 mm

kabelschlepp.de

Fon: +49 2762 4003-0

Use our free project planning service.

Load diagram

for unsupported length L_f depending on the additional load

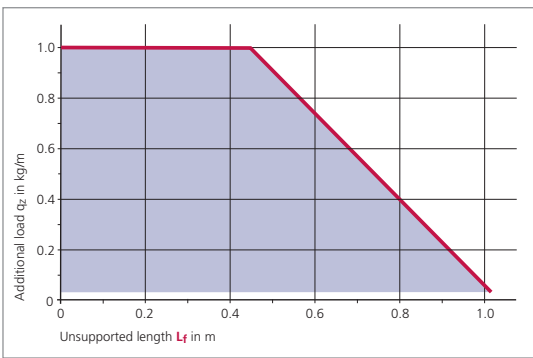

Unsupported length L_f

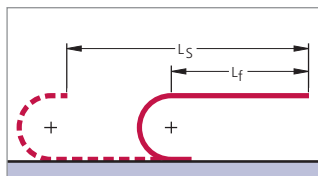

In the case of longer travel lengths, sag of the cable carriers is technically permissible depending on the application.

In a gliding arrangement, even longer travel lengths are possible (see page 295).

We are at your service to advise on these applications.

Example of ordering

Cable carrier	0202	-	10	-	28	-	460	Connection	FA/MA
Type	Inside width B _i in mm		Bend radius KR in mm		Chain length L _k in mm (without connection)		Connection Fixed point/Driver		

Type 0202

Connection dimensions

Plastic connectors
with integrated strain relief

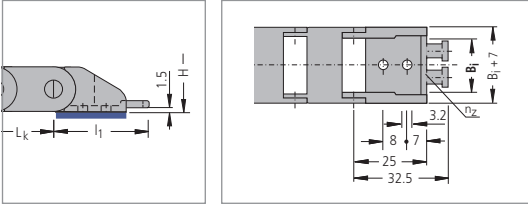

Type	B _i mm	B _k mm	n _Z
0202.06	6	13	1
0202.10	10	17	1
0202.15	15	22	2
0202.20	20	27	2

The dimensions of the fixed point and driver connections are identical.

Connection variants

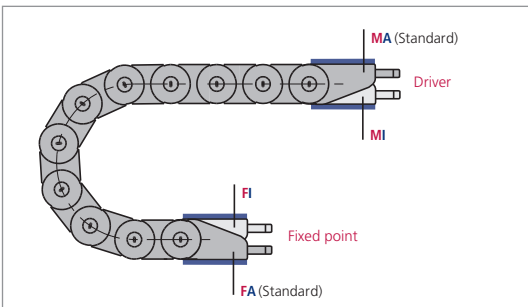

Connection point

- M** – Driver
- F** – Fixed point

Connection type

- A** – Threaded joint outside (standard)
- I** – Threaded joint inside

In the standard version, the connectors are mounted with the threaded joint outwards (**FA/MA**).

When ordering please specify the desired connection type (see ordering key on page 332).

The connection type can subsequently be altered simply by varying the connectors.

Inside height



Inside widths



kabelschlepp.de

Fon: +49 2762 4003-0

OnlineEngineer.de
with CableS
Cable Center Configurator

Type 0320

Inside/Outside: Not to be opened

Inside height



Inside widths

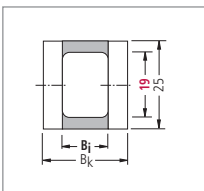
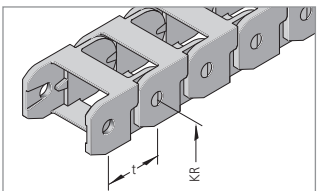

Type 0320.20 / .30

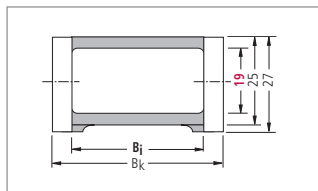

Type 0320 / .42 / .52 / .62 – with glide runners

Dimensions and intrinsic chain weight

Type 0320.20 / .30

Type	h _i mm	B _i mm	B _k mm	Intrinsic chain weight kg/m
0320.20	19	13	24	0.32
0320.30	19	19	30	0.35

Type 0320 / .42 / .52 / .62

Type	h _i mm	B _i mm	B _k mm	Intrinsic chain weight kg/m
0320.42	19	24	35	0.39
0320.52	19	29	40	0.44
0320.62	19	37	48	0.47

Bend radius and pitch

Type 0320.20 / .30

Bend radii KR mm		
37	47	77

Pitch t = 32.0 mm

Type 0320 / .42 / .52 / .62

Bend radii KR mm			
37	47	77	100

Pitch t = 32.0 mm

Load diagram

for unsupported length L_f depending on the additional load

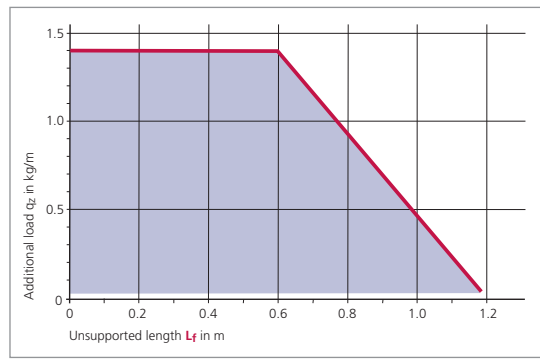

Unsupported length L_f

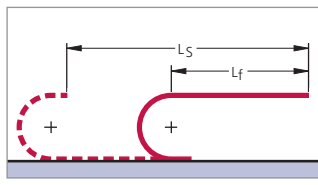

In the case of longer travel lengths, sag of the cable carriers is technically permissible depending on the application.

In a gliding arrangement, even longer travel lengths are possible (see page 295).

We are at your service to advise on these applications.

Example of ordering

Cable carrier	0320.42	-	77	-	800	Connection	FA/MA
Chain type	Bend radius KR in mm	Chain length L _k in mm (without connection)	Connection Fixed point/Driver				

kabelschlepp.de

Fon: +49 2762 4003-0

Use our free project planning service.

Type 0320

Connection dimensions

Plastic connectors
with integrated strain relief

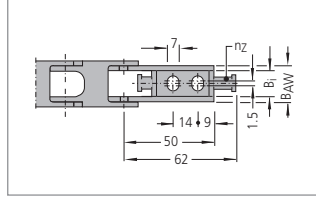
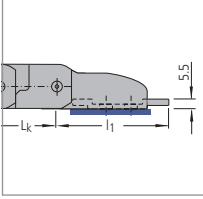

Type 0320.20

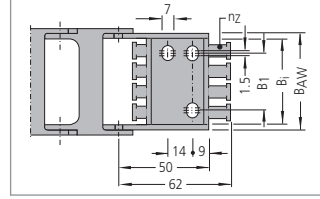

Type 0320.42 / .52 / .62

Inside
height

19

Inside
widths

13

37

Connection dimensions at
fixed point connection:

$$B_{AW} = B_i + 5.5$$

$$B_1 = B_i - 12.5$$

Connection dimensions at
driver connection:

$$B_{AW} = B_i + 11$$

$$B_1 = B_i - 10.5$$

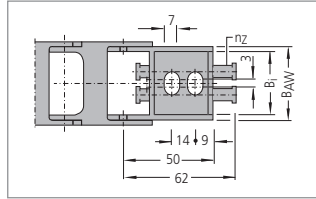

Type 0320.30

Type	B _i mm	B _k mm	n _z
0320.20	13	24	1
0320.30	19	30	2
0320.42	24	35	2
0320.52	29	40	3
0320.62	37	48	4

kabelschlepp.de

Connection variants

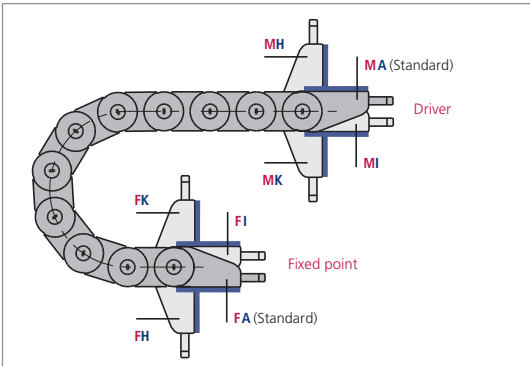

Connection point

- M** – Driver
- F** – Fixed point

Connection type

- A** – Threaded joint outside (standard)
- I** – Threaded joint inside
- H** – Threaded joint, rotated through 90° to the outside
- K** – Threaded joint, rotated through 90° to the inside

In the standard version, the connectors are mounted with the threaded joint outwards (**FA/MA**).

When ordering please specify the desired connection type (see ordering key on page 332).

The connection type can subsequently be altered simply by varying the connectors.

Fon: +49 2762 4003-0

OnlineEngineerde
with Concepts
Cable Carriers Configurator

Type 0450

Inside
heights24
-
28Inside
widths38
-
103

kabelschlepp.de

Fon:
+49 2762 4003-0Use our free
project planning service.

Inside/Outside: Not to be opened

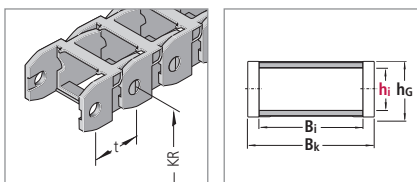

Outside: Hinged, openable and detachable brackets

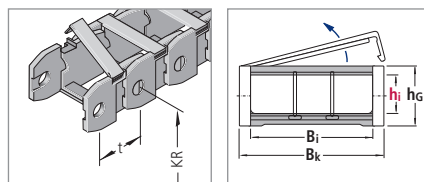

Dimensions and intrinsic chain weight

Inside/Outside:

Not to be opened – $h_i = 24$ mm

Type	h_i mm	h_G mm	B_i mm	B_k mm	Intrinsic chain weight kg/m
0450.20	24	34	38	54	0.65
0450.40	24	34	58	74	0.78
0450.60	24	34	78	94	0.92
0450.85	24	34	103	119	1.20

Outside:

Hinged, openable and detachable brackets – $h_i = 24$ mm

Type	h_i mm	h_G mm	B_i mm	B_k mm	Intrinsic chain weight kg/m
0450.21	24	40	38	54	0.75
0450.41	24	40	58	74	0.85
0450.61	24	40	78	94	0.92
0450.81	24	40	103	119	1.20

Inside/Outside:

Not to be opened – $h_i = 28$ mm

Type	h_i mm	h_G mm	B_i mm	B_k mm	Intrinsic chain weight kg/m
0450.22	28	40	38	54	0.75
0450.32	28	40	48	64	0.80
0450.42	28	40	58	74	0.85
0450.62	28	40	78	94	0.95
0450.82	28	40	103	119	1.10

Bend radius and pitch

Inside/Outside:

Not to be opened – $h_i = 24$ mm

Bend radii KR mm				
52	94	125	150	200

Pitch $t = 45.0$ mm

Outside:

Hinged, openable and detachable brackets – $h_i = 24$ mm

Bend radii KR mm				
52	94	125	150	200

For Type 0450.41, the KR 110 is also available.

Pitch $t = 45.0$ mm

Inside/Outside:

Not to be opened – $h_i = 28$ mm

Bend radii KR mm							
52	60	75	94	110	125	150	200

Pitch $t = 45.0$ mm

Type 0450

Load diagram

for unsupported length L_f depending on the additional load

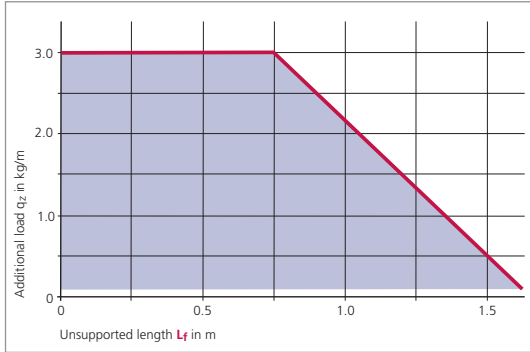

Unsupported length L_f

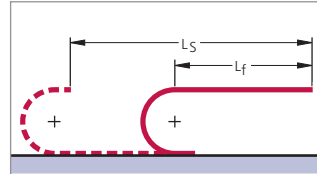

In the case of longer travel lengths, sag of the cable carriers is technically permissible depending on the application.

In a gliding arrangement, even longer travel lengths are possible (see page 295).

We are at your service to advise on these applications.

Inside heights



Inside widths



kabelschlepp.de

Example of ordering

Cable carrier			Divider system		Connection
Chain type	Bend radius KR in mm	Chain length L_k in mm (without connection)	Divider system	Number of dividers n_T	Connection Fixed point/ Driver
0450.61	94	900	TS 0 /	2	FA/MA

Ordering divider systems:

Please state the designation of the divider system (TS 0, TS 1 ...) and the number of dividers. Possibly attach a sketch with the dimensions.

Font:
+49 2762 4003-0

Guide channels
► from page 295



Strain relief devices
► from page 302



Cables for cable carrier systems
► from page 344



Type 0450

Divider system TS 0

For types not to be opened – $h_i = 24 \text{ mm}$

Type	S_T mm	a_T min mm	a_x min mm
0450	2.5	13.5	9

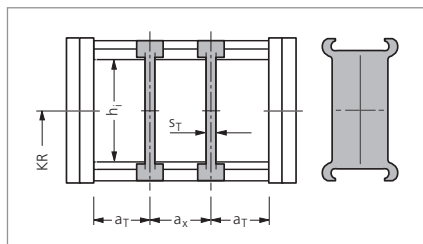

In the standard version, the divider systems are mounted on every second chain link.

Inside
heights



Inside
widths



For types not to be opened – $h_i = 28 \text{ mm}$

Type	S_T mm	a_T min mm	a_x min mm
0450	4.2	4.0	7.8

For types with hinged, openable and detachable brackets – $h_i = 24 \text{ mm}$

Type	S_T mm	a_T min mm	a_x min mm
0450	2.5	4.0	8.0

The dividers can be moved in the cross section.

kabelschlepp.de

Divider system TS 1 with continuous height subdivision made of plastic

For types not to be opened – $h_i = 28 \text{ mm}$

Type	S_T mm	S_H mm	a_T min mm	a_x min mm
0450	4.2	4	4.0	7.8

The dividers can be moved in the cross section.

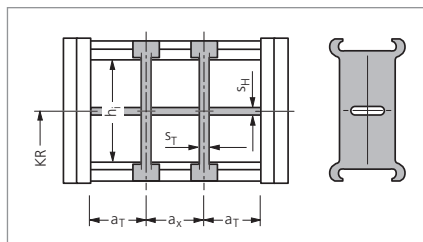

In the standard version, the divider systems are mounted on every second chain link.

Fon:
+49 2762 4003-0

Divider system TS 2 with grid subdivision made of plastic (4 mm grid)

For types not to be opened – $h_i = 28 \text{ mm}$

Type	S_T mm	S_H mm	a_T min mm	a_x min mm
0450	4.2	4	4.0	7.8

The dividers are fixed by the height separations, the complete divider system is movable.

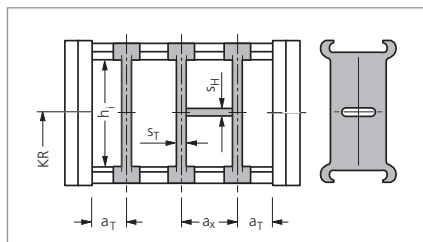

In the standard version, the divider systems are mounted on every second chain link.

Use our free
project planning service.

Type 0450

Connection dimensions

Plastic connectors
with integrated strain relief

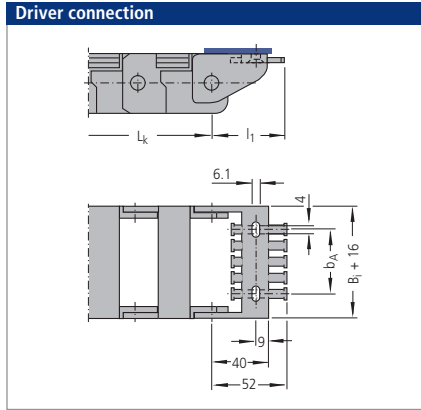
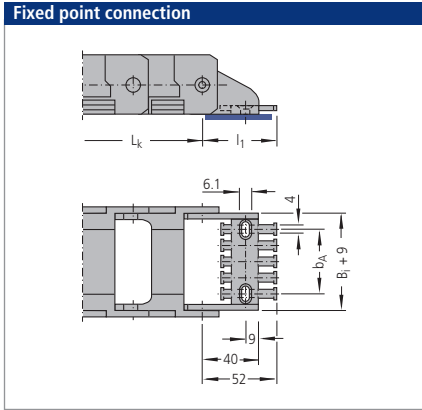

Inside heights



Inside widths



Type	B_i mm	B_k mm	b_A mm	n_Z
0450.20/.21/.22	38	54	24	3
0450.40/.41/.42	58	74	44	5
0450.60/.61/.62	78	94	64	7
0450.81/.82/.85	103	119	89	9

kabelschlepp.de

Connection variants

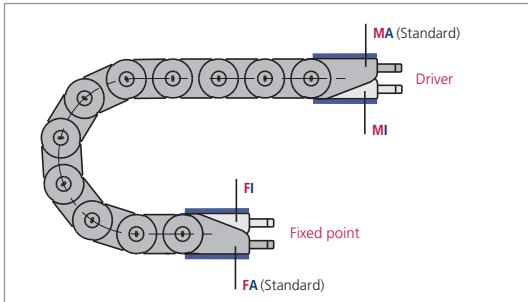

Connection point

- M** – Driver
- F** – Fixed point

Connection type

- A** – Threaded joint outside (standard)
- I** – Threaded joint inside

In the standard version, the connectors are mounted with the threaded joint outwards (**FA/MA**).

When ordering please specify the desired connection type (see ordering key on page 332).

The connection type can subsequently be altered simply by varying the connectors.

Subject to change.

Fon: +49 2762 4003-0

OnlineEngineer.de
with CableSlepp
Cable Chain Configurator

Type 0625

Inside heights



Inside widths



kabelschlepp.de

Fon: +49 2762 4003-0

Use our free project planning service.

Inside/Outside: Not to be opened

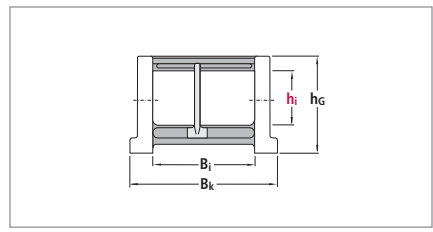
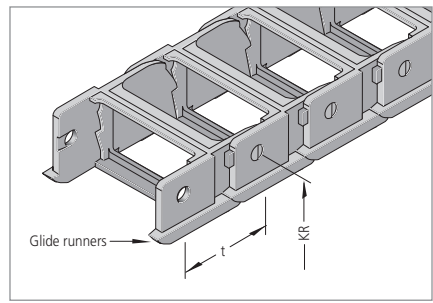

Outside: Hinged, openable and detachable brackets

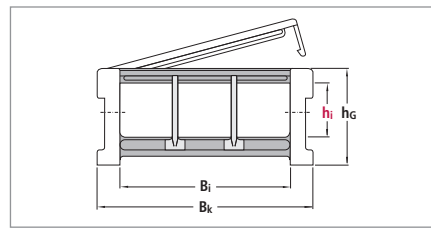
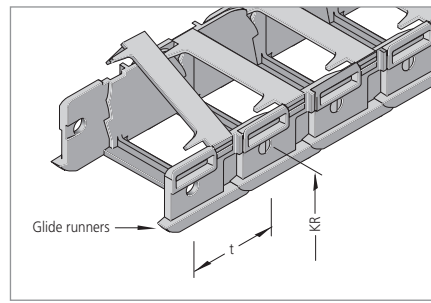

Dimensions and intrinsic chain weight

Inside/Outside: Not to be opened

Type	h_i mm	h_G mm	B_i mm	B_k mm	Intrinsic chain weight kg/m
0625.22	34	62	65	93	1.55
0625.40	34	56	108	126	1.40
0625.42	34	62	108	136	1.70

Injection moulded glide runners not for type 0625.40

Outside: Hinged, openable and detachable brackets

Type	h_i mm	h_G mm	B_i mm	B_k mm	Intrinsic chain weight kg/m
0625.23	34	62	65	93	1.55
0625.43	34	62	108	136	1.70
0625.25	42	62	65	93	1.74
0625.45	42	62	108	136	2.06
0625.55	42	62	125	153	2.07
0625.65	42	62	150	178	2.15
0625.75	42	62	169	197	2.37

Bend radius and pitch

Inside/Outside: Not to be opened

Bend radii KR mm				
75*	90	125	200	300

* Not for type 0625.22

Pitch t = 62.5 mm

Outside: Hinged, openable and detachable brackets

Bend radii KR mm				
90	125	150	200	250 300

For type 0625.43, KR 75 mm is also available

Pitch t = 62.5 mm

Type 0625

Load diagram

for unsupported length L_f depending on the additional load

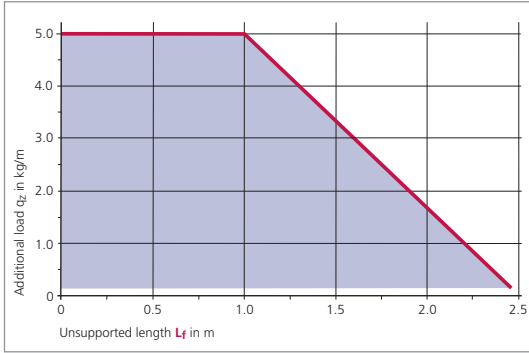

Unsupported length L_f

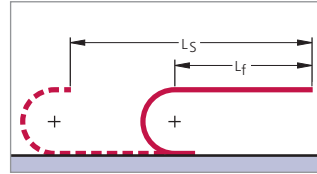

In the case of longer travel lengths, sag of the cable carriers is technically permissible depending on the application.

In a gliding arrangement, even longer travel lengths are possible (see page 295).

We are at your service to advise on these applications.

Inside heights

34
-
42

Inside widths

65
-
169

Example of ordering

Cable carrier			Divider system		Connection
Chain type	Bend radius KR in mm	Chain length L_k in mm (without connection)	Divider system	Number of dividers n_T	Connection Fixed point/ Driver
0625.65	125	1250	TS 0	2	FA/MA

Ordering divider systems:

Please state the designation of the divider system (TS 0, TS 1 ...) and the number of dividers. Possibly attach a sketch with the dimensions.

Font:
+49 2762 4003-0

OnlineEngineer.de
with
CONCEPT
Cable Carrier Configurator

Guide channels
► from page 295

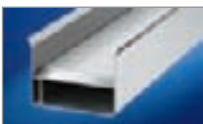

Strain relief devices
► from page 302



Cables for cable carrier systems
► from page 344



Type 0625

Divider system TS 0

Inside heights



Inside widths



Type	h_i mm	S_T mm	a_T min mm	a_x min mm
0625.22	34	3.5	6.0	12
0625.40				
0625.42				
0625.23	34	3.5	10.0	12
0625.43				
0625.25	42	4.0	11.0	11
0625.45				
0625.55				
0625.65				
0625.75				

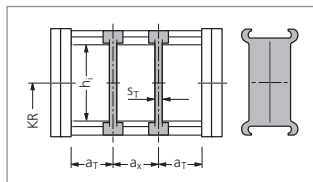

In the standard version, the divider systems are mounted on every second chain link.

The dividers can be moved in the cross section.

kabelschlepp.de

Divider system TS 1 with continuous height subdivision made of aluminium

Type	h_i mm	S_T mm	a_T min mm	a_x min mm	S_H mm	h_1 mm
0625.25	42	4	11	11	2	15
0625.45						
0625.55						
0625.65						
0625.75						

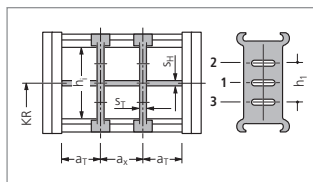

The dividers can be moved in the cross section.

In the standard version, the divider systems are mounted on every second chain link.

Height separation in Position 1 – 3 possible.

Fon: +49 2762 4003-0

Divider system TS 2 with grid subdivision made of aluminium (1 mm grid)

Type	h_i mm	S_T mm	a_T min mm	a_x min mm	S_H mm	h_1 mm
0625.25	42	6	12	20	4	15
0625.45						
0625.55						
0625.65						
0625.75						

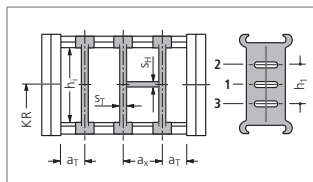

The dividers are fixed by the height separations, the complete divider system is movable.

In the standard version, the divider systems are mounted on every second chain link.

Use our free project planning service.

Type 0625

Connection dimensions

Standard end connector made of steel

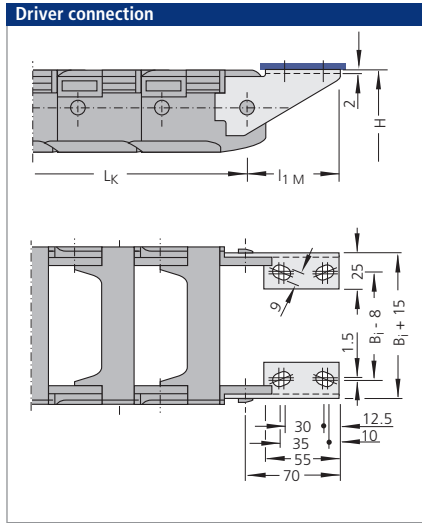
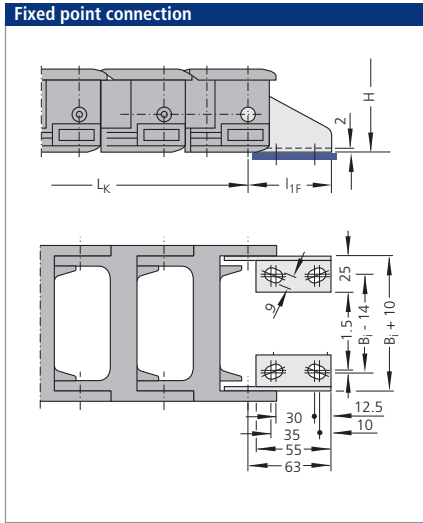

Connecting surface on the outside (not illustrated) possible on request.

Inside heights



Inside widths



kabelschlepp.de

Connectors with integrated strain relief are available. Please do get in touch with us.

Connection variants

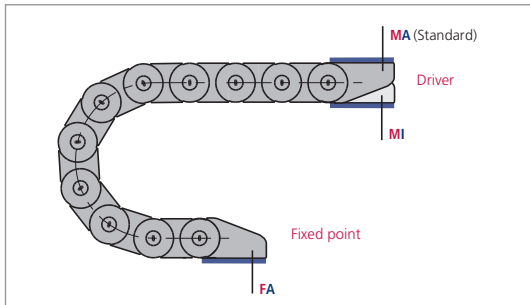

Connection point

- M** – Driver
- F** – Fixed point

Connection type

- A** – Threaded joint outside (standard)
- I** – Threaded joint inside

In the standard version, the connectors are mounted with the threaded joint outwards (**FA/MA**).

When ordering please specify the desired connection type (see ordering key on page 332).

The connection type can subsequently be altered simply by varying the connectors.

Subject to change.

Font:
+49 2762 4003-0

OnlineEngineer.de
KABELSCHLEPP
Cable Chain Configurator

QuickTrax
transforming the power to innovate

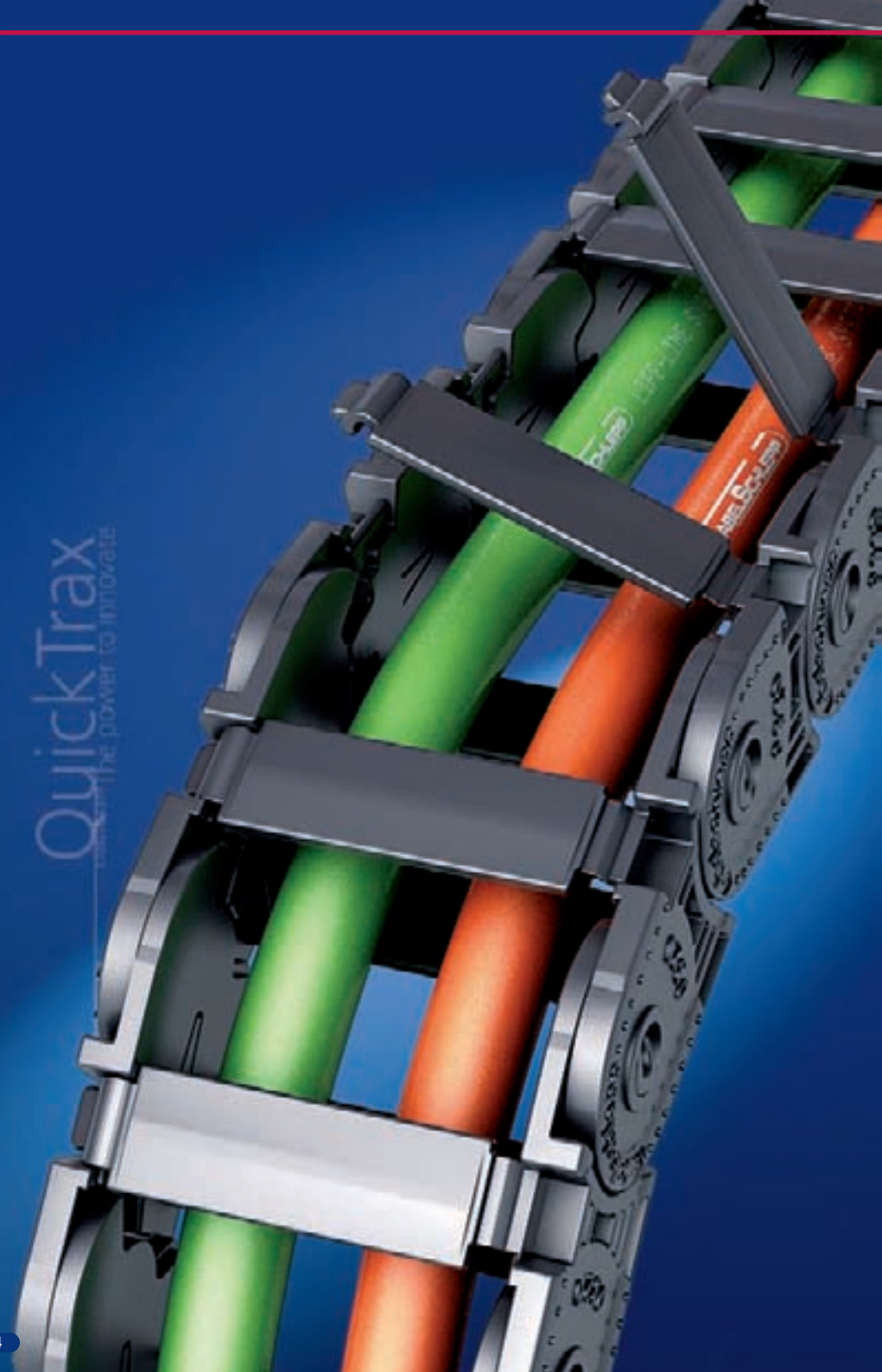

QuickTrax

Compact and cost-effective cable carriers in two-component technology

- Extremely fast and easy cable laying thanks to crossbar with film hinge
- Very quiet thanks to integrated noise damping system
- Stable chain construction
- Extensive unsupported length
- High torsional rigidity



Inside height



Inside widths



kabelschlepp.de

Font: +49 2762 4003-0

OnlineEngineer.de
KABELSCHLEPP
Cable Carrier Configurator



Easy to open



High side stability



Reliable cable separation

Overview QuickTrax

Design 030 with outward opening brackets

Inside height



Inside widths

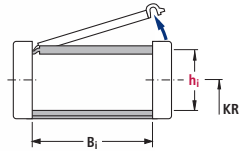

kabelschlepp.de

Type	h _i	B _i	Maximum travel length in m	Dynamics of unsupported arrangement		Page
				Travel speed v _{max} in m/s	Travel acceleration a _{max} in m/s ²	
QT 0320.030	20	15-50	80	10	50	78

Dimensions in mm

Design 040 with inward opening brackets

Fon: +49 2762 4003-0

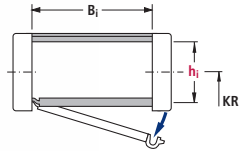

Type	h _i	B _i	Maximum travel length in m	Dynamics of unsupported arrangement		Page
				Travel speed v _{max} in m/s	Travel acceleration a _{max} in m/s ²	
QT 0320.040	20	15-50	80	10	50	78

Dimensions in mm

Use our free project planning service.

The 2-shot-technology of QuickTrax 0320

The 2-shot-technology of **QuickTrax 0320** makes it possible to unite seemingly non-integral characteristics: **Ruggedness and Flexibility.**

Cable carriers should be very rugged and have an extensive supporting length. At the same time they should afford quick and easy set-up. **QuickTrax 0320** unites these qualities through an innovative design and the materials combination of hard chain elements made of fiberglass reinforced material with crossbars with film hinges made of specially formulated flexible synthetics/plastics.

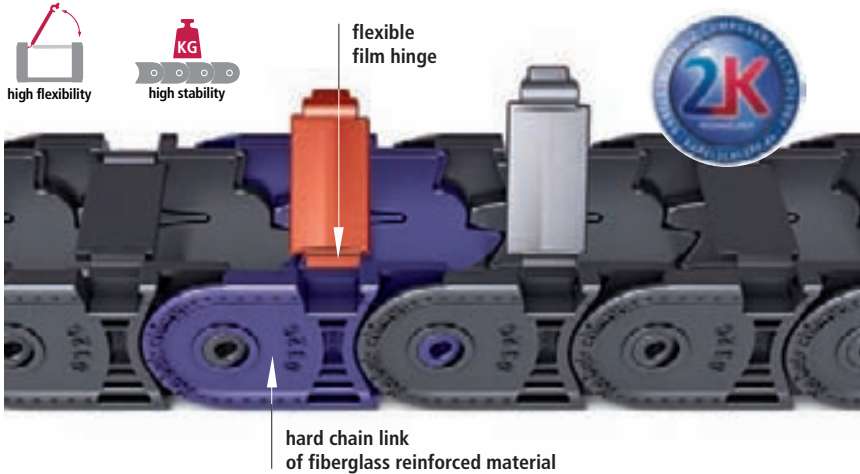

Inside height



Inside widths



kabelschlepp.de

Hand opening – opening and closing even without tools

Thanks to their special shaping and flexible material, the crossbars can be **unlocked very easily by hand**. They can also be opened just as easily with a screwdriver. The crossbars are connected to the carrier by a film hinge so that they cannot be lost, and thus remain attached to the chain link even when they are open.



Font: +49 2762 4003-0

High side stability through locking in the stroke system

The stops are locked in the bend radius stop and pretension stop. This prevents snapping out in these areas and achieves very high lateral stability.



OnlineEngineer.de
With Cable Carrier
 Cable Carrier Configurator

Type QT 0320

Inside height



Inside widths



Design 030

Outside: Hinged, openable brackets

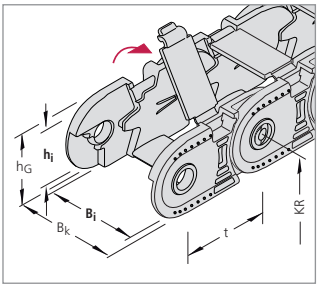

Design 040

Inside: Hinged, openable brackets

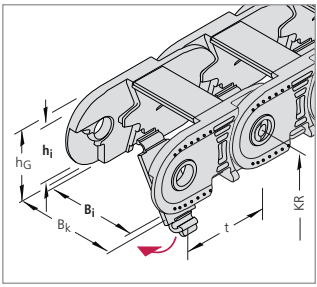

kabelschlepp.de

Dimensions and intrinsic chain weight

Type	h _i	h _G	Inside widths B _i				B _k
			Intrinsic chain weight				
QT 0320	20	25.5	15*	25	38	50*	B _i + 12
			0.18	0.28	0.42	0.55	

* on request

Dimensions in mm/Weights in kg/m

Bend radius and pitch

Bend radii KR mm				
28	38	48	75	100*

Pitch t = 32.0 mm

* on request

Load diagram

for unsupported length L_f depending on the additional load

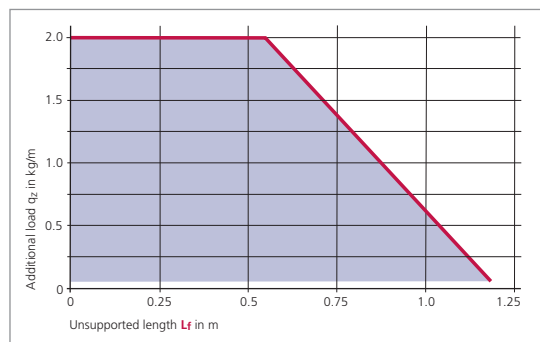

Unsupported length L_f

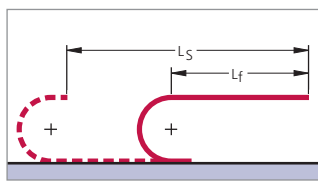

In the case of longer travel lengths, sag of the cable carriers is technically permissible depending on the application.

In a gliding arrangement, even longer travel lengths are possible (see page 295).

We are at your service to advise on these applications.

Fon: +49 2762 4003-0

Use our free project planning service.

Example of ordering

Cable carrier					Divider system		Connection
QT 0320	030	38	48	640	TS 0	1	FA/MA
Type	Design	Inside width B _i in mm	Bend radius KR in mm	Chain length L _k in mm (without connection)	Divider system	Number of dividers n _T	Connection Fixed point/Driver

Ordering divider systems:

Please state the designation of the divider system (TS 0, TS 1 ...) and the number of dividers. Possibly attach a sketch with the dimensions.

Type QT 0320

Divider system TS 0

Type	h_i mm	S_T mm
QT 0320	20	2

The dividers can be moved in the cross section.

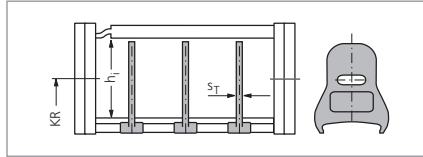

In the standard version, the divider systems are mounted on every second chain link.

Inside height



Inside widths



kabelschlepp.de

Divider system TS 1 with continuous height subdivision made of aluminium

Type	h_i mm	S_T mm	S_H mm
QT 0320	20	2	2.4

The dividers can be moved in the cross section.

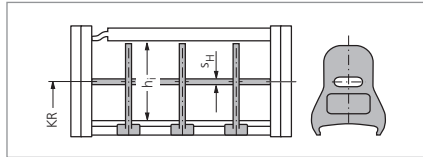

In the standard version, the divider systems are mounted on every second chain link.

Font: +49 2762 4003-0



OnlineEngineer.de
Web-Configurator
 Cable Carriers Configurator

Type QT 0320

Connection dimensions

Plastic connectors with integrated strain relief

Inside height



Inside widths

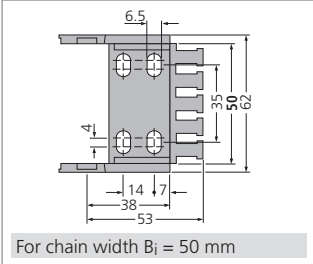
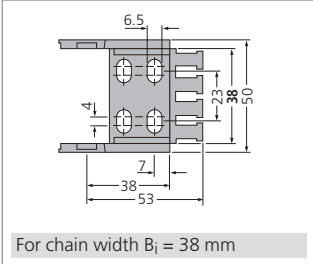
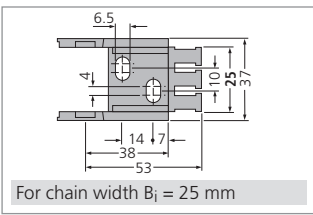
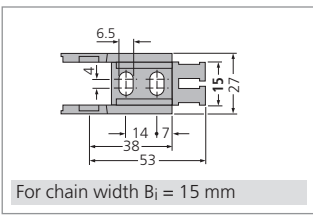
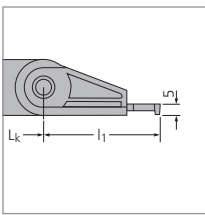

The dimensions of the fixed point and driver connections are identical.

Type	B_i	B_k	n_z
QT 032015	15	27	2
QT 032025	25	37	3
QT 032038	38	50	4
QT 032050	50	62	5

Dimensions in mm



Fon: +49 2762 4003-0

Use our free project planning service.

Mounting brackets without a strain relief comb are also available – please contact us.



Type QT 0320

Connection variants

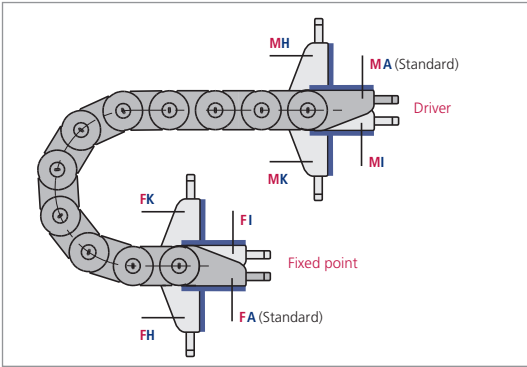

In the standard version, the connectors are mounted with the threaded joint outwards (**FA/MA**).

When ordering please specify the desired connection type (see ordering key on page 333).

The connection type can subsequently be altered simply by varying the connectors.

Connection point

- M** – Driver
- F** – Fixed point

Connection type

- A** – Threaded joint outside (standard)
- I** – Threaded joint inside
- H** – Threaded joint, rotated through 90° to the outside
- K** – Threaded joint, rotated through 90° to the inside



Inside height



Inside widths



kabelschlepp.de

Font:
+49 2762 4003-0

OnlineEngineer.de
with CableSlepp
Cable Carrier Configurator

Guide channels
▶ from page 295

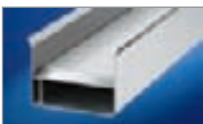

Strain relief devices
▶ from page 302



Cables for cable carrier systems
▶ from page 344



UNIFLEX Advanced

...The power to innovate



UNIFLEX *Advanced*

Light, quiet all-rounder with wide range of applications

- Cost-effective cable carrier
- Weight-optimized chain geometry
- Particularly high torsional rigidity

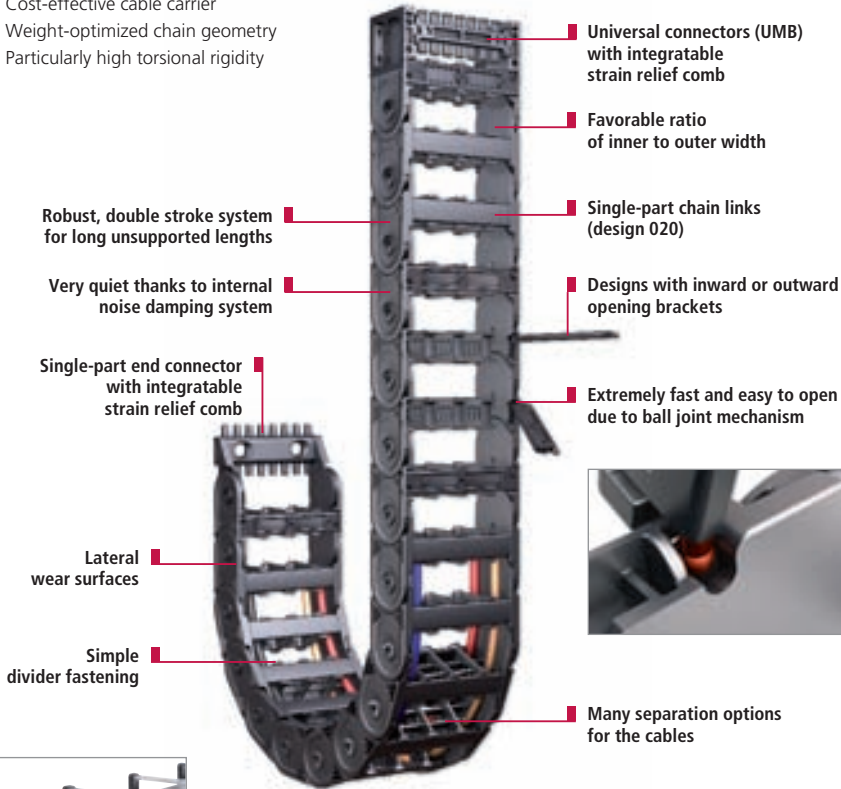

Inside heights



Inside widths



kabelschlepp.de

Fon: +49 2762 4003-0

OnlineEngineer.de
KABELSCHLEPP
Cable Carrier Configurator

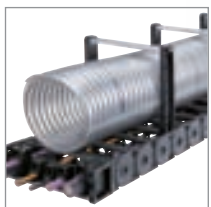

UNIFLEX Advanced 1665 with mounting frame stay

The mounting frame stay can be used to reliably route cables with a very large diameter such as extraction hoses, which diameters are greater than the clearance height of the chain links can be routed.



Dividers can be fixed for installations where the carrier is rotated through 90° and applications with high transverse accelerations – no additional spacers are needed



Lateral wear surfaces – for long service life for applications where the carrier is rotated through 90°



Simple fixing of strain relief comb or C-Rail in the connector



Design 020 with enclosed frame

Inside heights



Inside widths

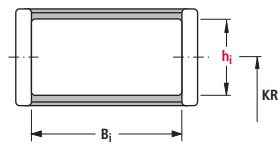
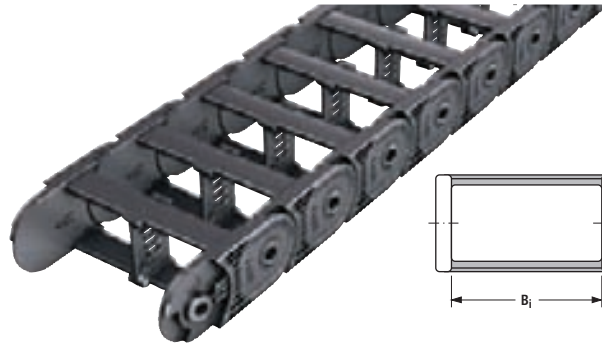

Type	h_i	B_i	Maximum travel length in m	Dynamics of unsupported arrangement		Page
				Travel speed v_{max} in m/s	Travel acceleration a_{max} in m/s ²	
1455.020	26	25-103	120	10	50	86
1555.020	38	50-150	125	9	45	86
1665.020	44	50-250	150	8	40	86

Dimensions in mm

kabelschlepp.de

Fon: +49 2762 4003-0

Design 030 with outward opening and detachable brackets

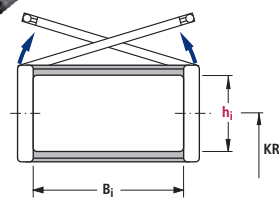
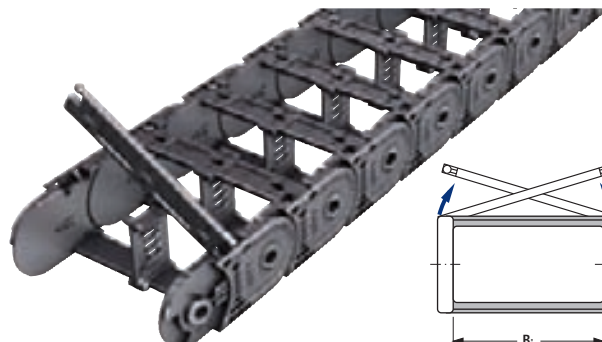

Type	h_i	B_i	Maximum travel length in m	Dynamics of unsupported arrangement		Page
				Travel speed v_{max} in m/s	Travel acceleration a_{max} in m/s ²	
1455.030	26	25-103	120	10	50	86
1555.030	38	50-150	125	9	45	86
1665.030	44	50-250	150	8	40	86

Dimensions in mm

Use our free project planning service.

Overview UNIFLEX *Advanced*

Design 040 with inward opening and detachable brackets

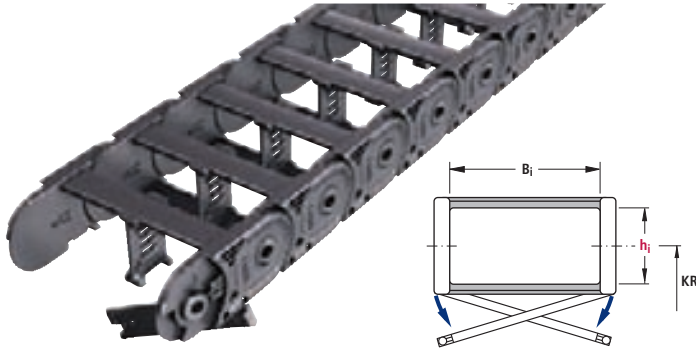

Inside heights



Inside widths



Type	h _i	B _i	Maximum travel length in m	Dynamics of unsupported arrangement		Page
				Travel speed v _{max} in m/s	Travel acceleration a _{max} in m/s ²	
1455.040	26	25-103	120	10	50	86
1555.040	38	50-150	125	9	45	86
1665.040	44	50-250	150	8	40	86

Dimensions in mm

kabelschlepp.de

UNIFLEX Advanced 1665 with mounting frame stay

The mounting frame stay can be used to reliably route cables with a very large diameter, such as extraction hoses, which diameters are greater than the clearance height of the chain links can be routed.

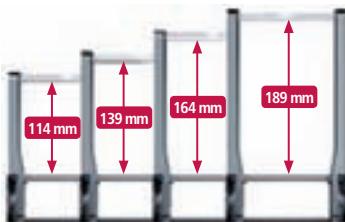

■ Different inside heights for different cable diameters



Font: +49 2762 4003-0

Additional chambers for further cables

Routing of additional cables with small diameters such as electrical or hydraulic cables is possible in the chambers under the main chamber. Dividers can be used for additional separation of the cables.



OnlineEngineer.de
KABELSCHLEPP
Cable Carrier Configurator

Do you need further information?
Please do get in touch with us, we will be pleased to help you.

Types 1455, 1555 and 1665

Inside heights



Inside widths



Design 020

Inside/Outside:
Not to be opened

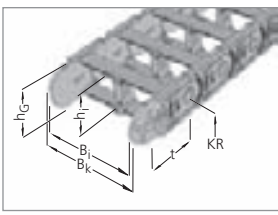

Design 030

Outside: Hinged, openable (on the right/left) and detachable brackets

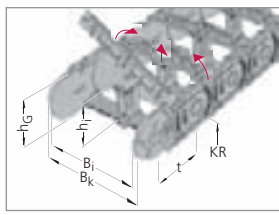

Design 040

Inside: Hinged, openable (on the right/left) and detachable brackets

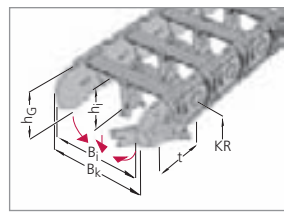

kabelschlepp.de

Dimensions and intrinsic chain weight

Type	h _i	h _G	Inside widths B _i								B _k	
			Intrinsic chain weight									
1455	26	36	25	38	58	78	103	—	—	—	—	B _i + 16
			0.73	0.75	0.80	0.88	0.98	—	—	—	—	
1555	38	50	50	75	90*	100	125	150	—	—	—	B _i + 18
			1.13	1.23	1.29	1.32	1.42	1.51	—	—	—	
1665	44	60	50	75	100	125	150	175	200**	225	250	B _i + 22
			1.67	1.80	1.92	2.06	2.18	2.31	2.43	2.57	2.70	

* Design 020 available on request ** on request Dimensions in mm/Weights in kg/m

Bend radius and pitch

Type	Bend radii KR mm							
1455	52	65	95	125	150	180	200	225*
1555	63	80	100	125	160	200	230**	—
1665	75	100	120	140	200	250	300	—

Pitch:
1455: t = 45.5 mm
1555: t = 55.5 mm
1665: t = 66.5 mm

* on request ** B_i 50 and 75 mm on request

Fon: +49 2762 4003-0

Load diagram

for unsupported length L_f depending on the additional load

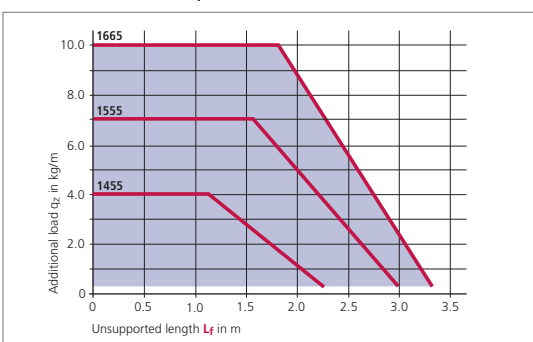

Unsupported length L_f

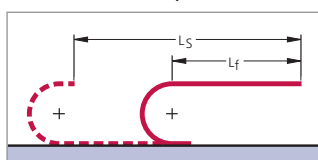

In the case of longer travel lengths, sag of the cable carriers is technically permissible depending on the application.

In a gliding arrangement, even longer travel lengths are possible (see page 295). We are at your service to advise on these applications.

Use our free project planning service.

Example of ordering

Cable carrier: **1555** · **030** · **100** · **125** · **1332**

Type: Design Inside width B_i in mm Bend radius KR in mm Chain length L_k in mm (without connection)

Divider system: **TS 0** / **3**

Connection: **FU/MU**

Divider system: Divider system Number of dividers n_T Connection: Fixed point/Driver

Ordering divider systems:

Please state the designation of the divider system (TS 0, TS 1 ...) and the number of dividers. Possibly attach a sketch with the dimensions.

Types 1455, 1555 and 1665

Fixing of the dividers

In the standard version, dividers or the complete divider system (dividers with height separation) can be moved in the cross section (**Version A**).

Fixed dividers are available for applications with transverse accelerations and where the carrier is rotated through 90° (**Version B**).

If the fixed installation version is desired, please state this on the order.

Version A (Standard)

Divider movable



Version B

Divider fixed in 2.5 mm steps

With fixed dividers, fixing is by means of arresting cams in the foot of the divider.



■ Locking profile in the crossbar



■ Divider with arresting cams

Inside heights

26
-
44

Inside widths

25
-
250

kabelschlepp.de

Divider system TS 0

Type	h _i mm	Version A			Version B			
		S _T mm	a _T min mm	a _x min mm	S _T mm	a _T min mm	a _x min mm	a _x section mm
1455	26	2.0	3.5	7	2.0	4/5*	7.5	2.5
1555	38	2.5	5.0	10	2.5	5	10	2.5
1665	44	3.0	5.0	10	3.0	5	10	2.5

* a_T min = 4 mm for B_i = 38, 58, 78, 103

a_T min = 5 mm for B_i = 25

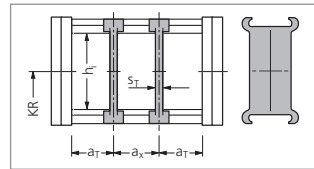

Font: +49 2762 4003-0

Divider system TS 1 for Design 030/040 with continuous height subdivision made of aluminium

Type	h _i mm	Version A			Version B				S _H mm	h ₁ mm	h ₂ mm
		S _T mm	a _T min mm	a _x min mm	S _T mm	a _T min mm	a _x min mm	a _x section mm			
1455	26	2.0	4/5*	7.5	2.0	4/5*	7.5	2.5	2	10	-
1555	38	2.5	5	10	2.5	5	10	2.5	4	14	-
1665	44	3.0	5	10	3.0	5	10	2.5	4	14	28

* a_T min = 4 mm for B_i = 38, 58, 78, 103

a_T min = 5 mm for B_i = 25

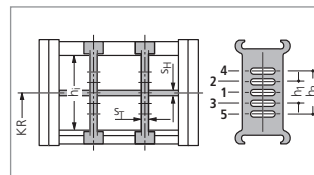
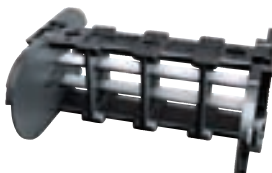

OnlineEngineer.de
KABELSCHLEPP
Cable Carrier Configurator

Types 1455, 1555 and 1665

Divider system TS 3 with section subdivision, partitions made of plastic

Inside heights

26
-
44

Type	h_i mm	S_T mm	S_H mm	h_1 mm	h_2 mm
1455	26	5	2.4	10	-
1555	38	5	2.4	12	-
1665	44	8	4.0	14	28

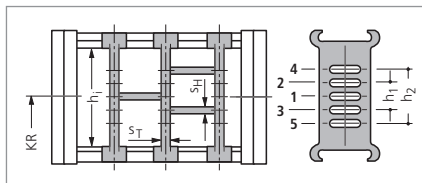

In the standard version, the divider systems are mounted on every second chain link.

Inside widths

25
-
250

The dividers are fixed by the partitions, the complete divider system is movable.

Dimensions of the plastic partitions for TS 3

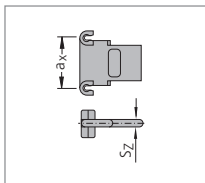

Types 1455 and 1555

S_z	a_x (Center to center distance, dividers)									
2.4	15	20	25	30	35	40	45	55	65	75

Type 1665

S_z	a_x (Center to center distance, dividers)									
4	16	18	23	28	32	33	38	43	48	58
	64	68	78	80	88	96	112	128	144	160

Dimensions in mm

For type 1665, aluminium partitions in 1 mm width sections are available.

When using **partitions with $a_x > 112$ mm**, there should be an additional central support with a **twin divider** ($S_T = 3$ mm).

Twin dividers are designed for subsequent fitting in the partition system.

Fon:
+49 2762 4003-0

Use our free
project planning service.

Types 1455, 1555 and 1665

Strain relief devices for plastic connectors

ZLK - A

Connecting elements with integrated strain relief combs on both sides (ZLK - A)



ZLK - L

Connecting elements with screw-on type strain relief combs (ZLK - L)

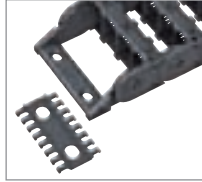

The strain relief combs are generally supplied with the connecting elements.

The combs are either clipped to the end connectors and bolted together with them, or screwed on at the desired intervals by using additional boreholes, behind the connecting elements.

Inside heights



Inside widths



Connection dimensions for Type 1455

Connecting elements with strain relief combs on both sides

ZLK - A
integrated strain relief combs

For chain width
 $B_i = 25$ mm

ZLK - L
screwable strain relief combs

For chain width
 $B_i = 38 - 103$ mm

Type	B_i	B_k	n_z
145525	25	41	2
145538	38	54	3
145558	58	74	4
145578	78	94	6
1455103	103	119	8

Dimensions in mm

The dimensions of the fixed point and driver connections are identical.

Connection dimensions for Type 1555

Connecting elements with strain relief combs on both sides

ZLK - L
screwable strain relief combs

Type	B_i	B_k	n_z
155550	50	68	4
155575	75	93	6
1555100	100	118	8
1555125	125	143	10
1555150	150	168	12

Dimensions in mm

For chain width B_i 90 mm connectors made of steel are available.

Types 1455, 1555 and 1665

Connection dimensions for Type 1665

Connecting elements with strain relief combs on both sides

Inside heights



Inside widths

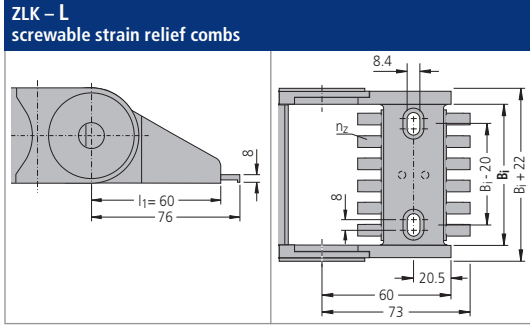

Type	B _i	B _k	n _z
1665.50	50	72	4
1665.75	75	97	6
1665.100	100	122	8
1665.125	125	147	10
1665.150	150	172	12
1665.175	175	197	14
1665.200*	200	222	16
1665.225	225	247	18
1665.250	250	272	20

* on request Dimensions in mm

The dimensions of the fixed point and driver connections are identical.

kabelschlepp.de

Connection variants

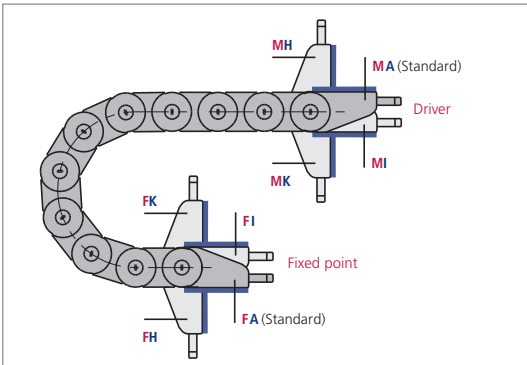

Connection point

- M** – Driver
- F** – Fixed point

Connection type

- A** – Threaded joint outside (standard)
- I** – Threaded joint inside
- H** – Threaded joint, rotated through 90° to the outside
- K** – Threaded joint, rotated through 90° to the inside

In the standard version, the connectors are mounted with the threaded joint outwards (**FA/MA**).

When ordering please specify the desired connection type (see ordering key on page 334).

The connection type can subsequently be altered simply by varying the connectors.

Fon: +49 2762 4003-0

Use our free project planning service.

Types 1455, 1555 and 1665

Universal mounting brackets

With plastic UMBs (Universal Mounting Brackets), you can easily connect the UNIFLEX from above, from below, or at head height.



Inside heights

26
-
44

Inside widths

25
-
250

UNIFLEX 1455

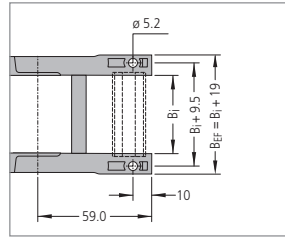
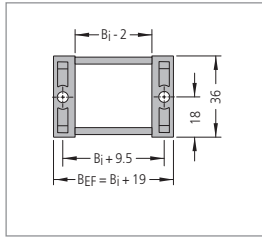
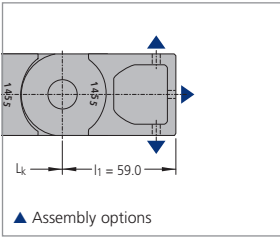

UNIFLEX 1555

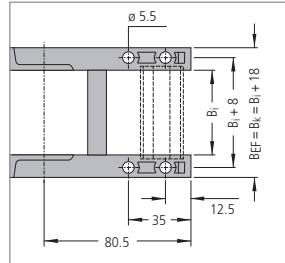
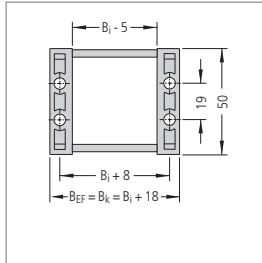
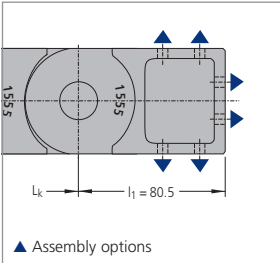

UNIFLEX 1665

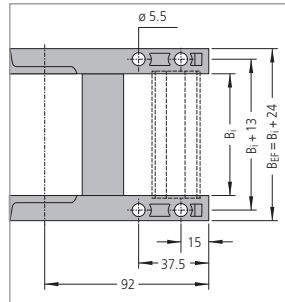
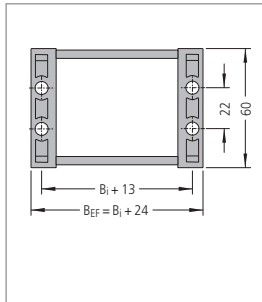
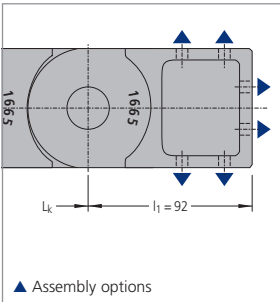

The dimensions of the fixed point and driver connections are identical.
When ordering please specify the connection type FU/MU (see ordering key on page 334).

kabelschlepp.de

Fon: +49 2762 4003-0

OnlineEngineer.de
KABELSCHLEPP
Cable Carrier Configurator

Types 1455, 1555 and 1665

Strain relief devices

Inside
heights

26
—
44

Inside
widths

25
—
250

kabelschlepp.de

Fon:
+49 2762 4003-0

Use our free
project planning service.

One-sided strain relief combs made of plastic (UNIFLEX 1455)

The cables can be fixed securely and simply using the **optional strain relief combs**.

The strain relief combs are installed between the UMBs, and do not need to be bolted on separately or mounted on a C-Rail.

Please state on the order whether strain relief combs are needed.



■ Universal mounting bracket with strain relief comb



■ One-sided strain relief comb



■ Fixing in the UMB

Type	B _i mm	n _z
1455.25	25	2
1455.38	38	3
1455.58	58	5
1455.78	78	7
1455.103	103	9

n_z = Number of teeth

Both-sided strain relief combs made of plastic (UNIFLEX 1555/1665)

The cables can be fixed securely and simply using the **optional strain relief combs**.

The strain relief combs are installed between the UMBs, and do not need to be bolted on separately or mounted on a C-Rail.

Please state on the order whether strain relief combs are needed.



■ Universal mounting bracket with strain relief comb



■ Both-sided strain relief comb



■ Fixing in the UMB

Type	B _i mm	n _z	Type	B _i mm	n _z
1555.50	50	3	1665.50	50	3
1555.75	75	5	1665.75	75	5
1555.90	90*	7	1665.100	100	7
1555.100	100	7	1665.115	115	8
1555.125	125	9	1665.125	125	9
1555.150	150	11	1665.150	150	11
			1665.175	175	13
			1665.225	225*	17
			1665.250	250*	19

n_z = Number of teeth on one side of the comb

* on request

Types 1455, 1555 and 1665

Strain relief devices

C-rails for LineFix bracket clamps, SZL strain reliefs and clamps (UNIFLEX 1555/1665)

The optional C-rails are fixed by means of the universal mounting brackets and do not have to be screwed separately.

Please state in your order whether C-rails are needed.

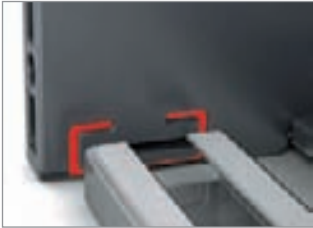

■ Universal mounting bracket with C-rail

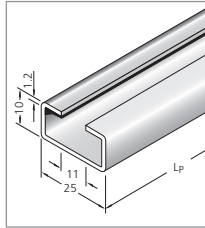

■ Integratable C-rail
25 x 10 mm,
slit width 11 mm,
material steel,
Item-No. 3931

Our LineFix strain reliefs are optimally suited for the C-rails (LineFix bracket clamps and other strain relief devices – see Accessories chapter, from page 302 onwards).



■ C-rail with LineFix strain relief

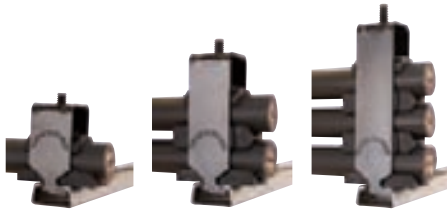

Inside heights



Inside widths



kabelschlepp.de

Font:
+49 2762 4003-0

OnlineEngineer.de
Kabelschlepp
Cable Carrier Configurator

Guide channels
➤ from page 295

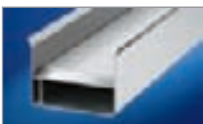

Strain relief devices
➤ from page 302



Cables for cable carrier systems
➤ from page 344



UNIFLEX
The power to innovate



UNIFLEX

Proven cable carrier with many opening and cover variants*

- Cost-effective cable carrier
- Particularly high torsional rigidity
- TÜV design approved in accordance with 2PFG 1036/10.97

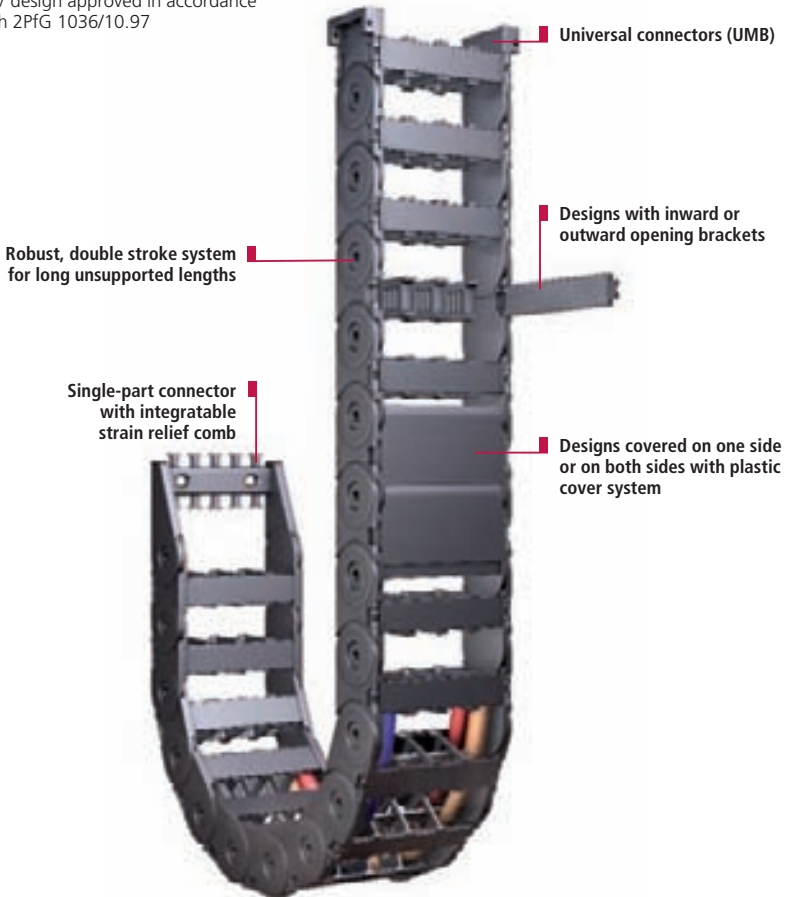

Inside heights



Inside widths



kabelschlepp.de

Font: +49 2762 4003-0

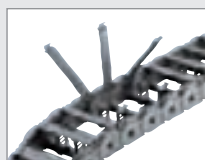

Design 030 with outward opening and detachable brackets



Design 040 with inward opening and detachable brackets



Design 050 – covered on one side



Design 060/080 – TUBE SERIES covered cable carriers

Subject to change.

* Some features can be different for certain types for design reasons. Our specialists are happy to advise you.

OnlineEngineer.de
with KABELSCHLEPP
 Cable Carrier Configurator

Overview UNIFLEX

Design 030 with outward opening and detachable brackets

Inside heights



Inside widths

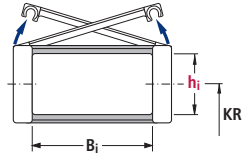
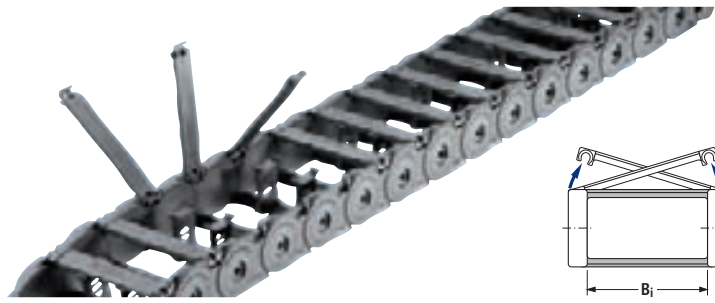

kabelschlepp.de

Type	hi	Bi	Maximum travel length in m	Dynamics of unsupported arrangement		Page
				Travel speed v _{max} in m/s	Travel acceleration a _{max} in m/s ²	
0250.030	17.5	20-80	60	10	50	98
0345.030	20	15-90	80	10	50	100
0455.030	26	25-130	120	10	50	100
0555.030	38	50-150	125	9	45	100
0665.030	44	50-250	150	8	40	100

Dimensions in mm

Design 040 with inward opening and detachable brackets

Font: +49 2762 4003-0

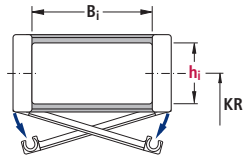

Type	hi	Bi	Maximum travel length in m	Dynamics of unsupported arrangement		Page
				Travel speed v _{max} in m/s	Travel acceleration a _{max} in m/s ²	
0345.040	20	15-90	80	10	50	100
0455.040	26	25-130	120	10	50	100
0555.040	38	50-150	125	9	45	100
0665.040	44	50-250	150	8	40	100

Dimensions in mm

Use our free project planning service.

Overview UNIFLEX

Design 050 – covered on one side

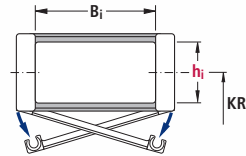

Inside heights



Inside widths



Type	hi	Bi	Maximum travel length in m	Dynamics of unsupported arrangement		Page
				Travel speed v _{max} in m/s	Travel acceleration a _{max} in m/s ²	
0345.050	20	15-65	80	10	50	102
0455.050	26	25-130	120	10	50	102
0555.050	38	50-150	125	9	45	102
0665.050	44	50-175	150	8	40	102

Dimensions in mm

kabelschlepp.de

TUBE SERIES – covered cable carriers

Design 060 with plastic cover system

- Outside and inside: Covered
- Inside: Hinged, openable (on the right/left) and detachable cover

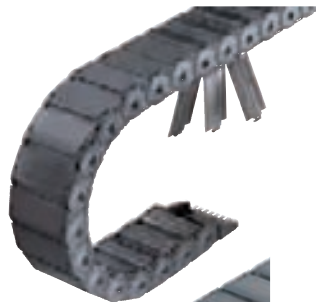

Design 080 – lightweight – with plastic cover system

- Outside: Detachable cover
- Inside: Covered



Font: +49 2762 4003-0

OnlineEngineer.de
KABELSCHLEPP
Cable Carrier Configurator

Type 0250

Design 030

Outside: Hinged, openable and detachable brackets

Inside height



Inside widths

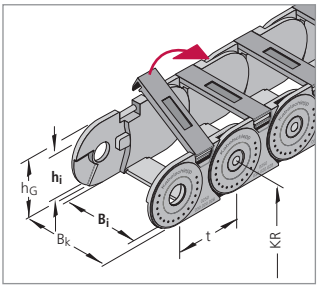

Dimensions and intrinsic chain weight

Type	h _i	h _G	Inside widths B _i					B _k	
			Intrinsic chain weight						
0250	17.5	23	20	30	40	50	65	80	B _i + 10
			0.26	0.31	0.33	0.35	0.38	0.41	

Dimensions in mm/Weights in kg/m

Bend radius and pitch

Bend radii KR mm					
28	38	45	60	75	100

Pitch t = 25.0 mm

kabelschlepp.de

Fon: +49 2762 4003-0

Use our free project planning service.

Load diagram

for unsupported length L_f depending on the additional load

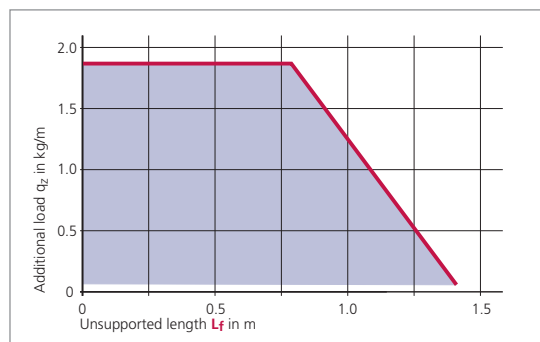

Unsupported length L_f

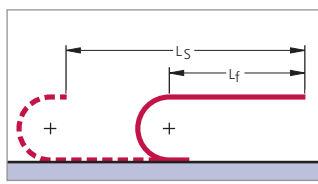

In the case of longer travel lengths, sag of the cable carriers is technically permissible depending on the application.

In a gliding arrangement, even longer travel lengths are possible (see page 295).

We are at your service to advise on these applications.

Example of ordering

Cable carrier			Divider system		Connection		
0250	030	40	45	650	TS 0 / 2	FA/MA	
Type	Design	Inside width B _i in mm	Bend radius KR in mm	Chain length L _k in mm (without connection)	Divider system	Number of dividers n _T	Connection Fixed point/Driver

Ordering divider systems:

Please state the designation of the divider system (TS 0, TS 1 ...) and the number of dividers. Possibly attach a sketch with the dimensions.

Type 0250

Divider system TS 0

Type	h_i mm	S_T mm
0250	17.5	2

The dividers can be moved in the cross section.

In the standard version, the divider systems are mounted on every second chain link.

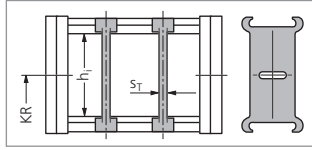

The divider system TS 1 with a **central** height sub-division ($S_H = 2.4$ mm) is also available for the type 0250.

Inside height



Inside widths



Connection dimensions

Plastic connectors with integrated strain relief

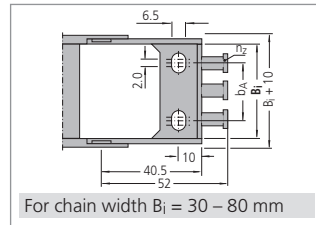
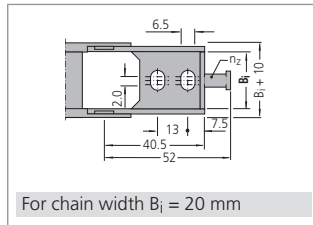
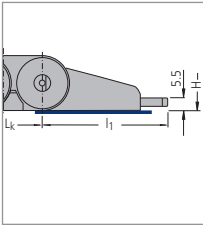

The dimensions of the fixed point and driver connections are identical.

Table of dimensions

Plastic connecting elements with strain relief combs

Type	B_i	B_k	b_A	n_z
0250	20	30	-	1
0250	30	40	15	2
0250	40	50	23	3
0250	50	60	33	4
0250	65	75	48	5
0250	80	90	63	6

Dimensions in mm

Connection variants

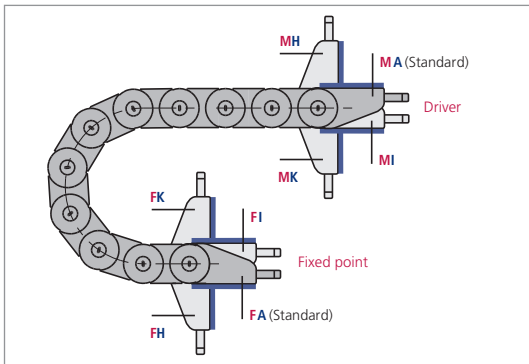

Connection point

- M** – Driver
- F** – Fixed point

Connection type

- A** – Threaded joint outside (standard)
- I** – Threaded joint inside
- H** – Threaded joint, rotated through 90° to the outside
- K** – Threaded joint, rotated through 90° to the inside

Subject to change.

In the standard version, the connectors are mounted with the threaded joint outwards (**FA/MA**). When ordering please specify the desired connection type (see ordering key on page 334). The connection type can subsequently be altered simply by varying the connectors.

kabelschlepp.de

Font:
+49 2762 4003-0

OnlineEngineer.de
with Cable Concepts
Cable Center Configurator

Types 0345, 0455, 0555 and 0665

Inside heights

20
-
44

Inside widths

15
-
250

Design 030

Outside: Hinged, openable (on the right/left) and detachable brackets

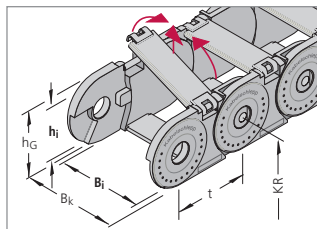

Design 040

Inside: Hinged, openable (on the right/left) and detachable brackets

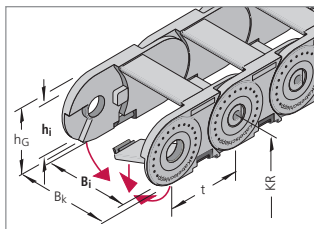

Design 035 and 045

When hydraulic hoses are being used with small bend radii, we recommend the use of lockable brackets – Designs .035 and .045.

kabelschlepp.de

Dimensions and intrinsic chain weight

Type	h_i	h_G	Inside widths B_i								B_k	
			Intrinsic chain weight									
0345	20	28	15	20	25	38	50	65	90	–	–	$B_i + 13$
			0.43	0.45	0.46	0.50	0.53	0.57	0.71	–	–	
0455	26	36	25	38	58	78	103	130	–	–	–	$B_i + 18$
			0.81	0.88	0.95	1.02	1.15	1.27	–	–	–	
0555	38	50	50	75	100	125	150	–	–	–	–	$B_i + 22$
			1.47	1.60	1.72	1.86	1.98	–	–	–	–	
0665	44	60	50	75	100	125	150	175	200	225	250	$B_i + 27$
			2.06	2.22	2.37	2.53	2.68	2.85	3.00	3.16	3.31	

Dimensions in mm/Weights in kg/m

Bend radius and pitch

Type	Bend radii KR mm							
0345	38	50	75	100	125	150	–	–
0455	52	65	95	125	150	180	200	225
0555	63	80	100	125	160	200	230	–
0665	75	100	120	140	200	250	300	–

Pitch t:

Type 0345: 34.5 mm

Type 0455: 45.5 mm

Type 0555: 55.5 mm

Type 0665: 66.5 mm

Fon: +49 2762 4003-0

Load diagram

for unsupported length L_f depending on the additional load

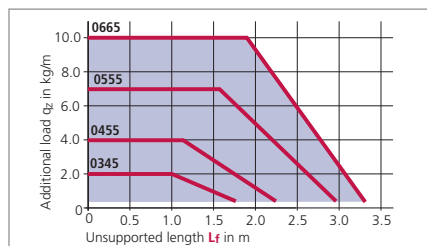

Unsupported length L_f

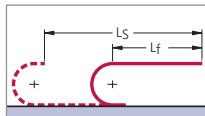

In the case of longer travel lengths, sag of the cable carriers is technically permissible depending on the application. In a gliding arrangement, even longer travel lengths are possible (see page 295).

We are at your service to advise on these applications.

Use our free project planning service.

Example of ordering

Cable carrier

0555

040

100

125

1332

Divider system

TS 0

3

Connection

FA/MA

Type

Design

Inside width B_i in mm

Bend radius KR in mm

Chain length L_k in mm (without connection)

Divider system

Number of dividers n_T

Connection Fixed point/Driver

Ordering divider systems:

Please state the designation of the divider system (TS 0, TS 1 ...) and the number of dividers. Possibly attach a sketch with the dimensions.

Types 0345, 0455, 0555 and 0665

Divider system TS 0

Type	h_i mm	S_T mm
0345	20	2
0455	26	2.5
0555	38	2.5
0665	44	3

The dividers can be moved in the cross section.

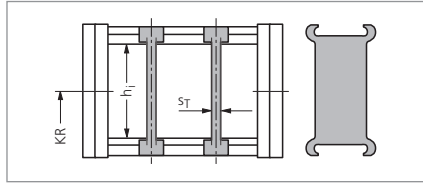

In the standard version, the divider systems are mounted on every second chain link.

Inside heights



Inside widths



Divider system TS 1 with continuous height subdivision made of aluminium

Type	h_i mm	S_T mm	S_H mm	h_1 mm	h_2 mm
0345	20	2	2.4	10	–
0455	26	2.5	2	10	–
0555	38	2.5	4	14	–
0665	44	3	4	14	28

The dividers can be moved in the cross section.

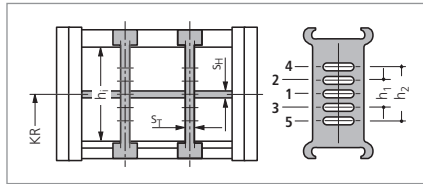

In the standard version, the divider systems are mounted on every second chain link.

Divider system TS 3 with section subdivision, partitions made of plastic

Type	h_i mm	S_T mm	S_H mm	h_1 mm	h_2 mm
0455	26	5	2.4	10	–
0555	38	5	2.4	12	–
0665	44	8	4.0	14	28

The dividers are fixed by the partitions, the complete divider system is movable.

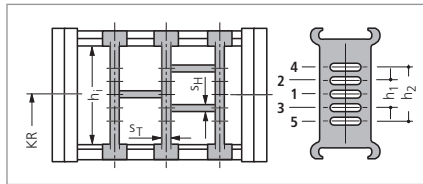

In the standard version, the divider systems are mounted on every second chain link.

kabelschlepp.de

Fon: +49 2762 4003-0

Dimensions of the plastic partitions for TS 3

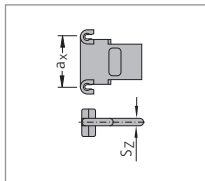

Types 0455 and 0555

S_Z	a_x (center-to-center distance, dividers)									
2.4	15	20	25	30	35	40	45	55	65	75

Type 0665

S_Z	a_x (center-to-center distance, dividers)									
4	16	18	23	28	32	33	38	43	48	58
	64	68	78	80	88	96	112	128	144	160
	176	192	208	–	–	–	–	–	–	–

Dimensions in mm

Subject to change.
For type 0665, aluminium partitions in 1 mm width sections are available.

When using partitions with $a_x > 112$ mm, there should be an additional central support with a twin divider ($S_T = 3$ mm).
Twin dividers are designed for subsequent fitting in the partition system.

OnlineEngineer.de
KABELSCHLEPP
Cable Center Configurator

Types 0345, 0455, 0555 and 0665

Design 050

Outside: Covered

Inside: Hinged, openable (on the right/left) and detachable brackets

Inside
heights

20
—
44

Inside
widths

15
—
175

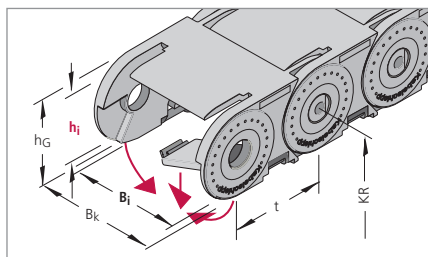

Design 055:

When hydraulic hoses are being used with small bend radii, we recommend the use of lockable brackets – Design 055.

kabelschlepp.de

Dimensions and intrinsic chain weight

Type	h_i	h_G	Inside widths B_i						B_k
			Intrinsic chain weight						
0345	20	28	15	20	25	38	50	65	$B_i + 13$
			0.46	0.49	0.52	0.59	0.66	0.75	
0455	26	36	25	38	58	78	103	130	$B_i + 18$
			0.89	0.97	1.10	1.22	1.40	1.58	
0555	38	50	50	75	100	125	150	–	$B_i + 22$
			1.64	1.81	1.98	2.16	2.33	–	
0665	44	60	50	75	100	125	150	175	$B_i + 27$
			2.26	2.53	2.79	3.06	3.33	3.60	

Dimensions in mm/Weights in kg/m

Fon:
+49 2762 4003-0

Bend radius and pitch

Type	Bend radii KR mm							
0345	38	50	75	100	125	150	–	–
0455	52	65	95	125	150	180	200	225
0555	63	80	100	125	160	200	230	–
0665	75	100	120	140	200	250	300	–

Pitch t:

Type 0345: 34.5 mm

Type 0455: 45.5 mm

Type 0555: 55.5 mm

Type 0665: 66.5 mm

Use our free
project planning service.

Example of ordering

Cable carrier

- - - -
 Type Design Inside width B_i in mm Bend radius KR in mm Chain length L_k in mm (without connection)

Divider system

/
 Divider system Number of dividers n_T

Connection

Connection Fixed point/Driver

Ordering divider systems:

Please state the designation of the divider system (TS 0, TS 1 ...) and the number of dividers. Possibly attach a sketch with the dimensions.

Types 0345, 0455, 0555 and 0665

Load diagram

for unsupported length L_f depending on the additional load

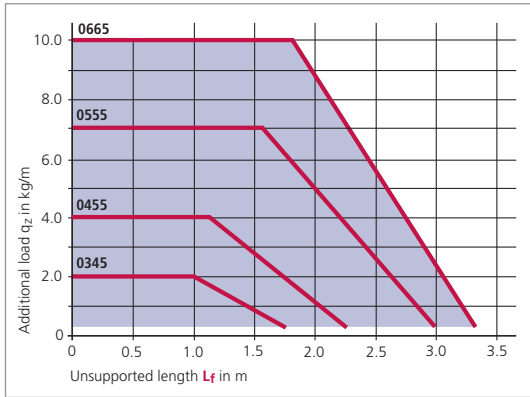

Unsupported length L_f

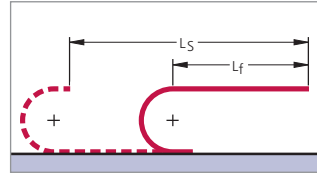

In the case of longer travel lengths, sag of the cable carriers is technically permissible depending on the application.

In a gliding arrangement, even longer travel lengths are possible (see page 295).

We are at your service to advise on these applications.

Inside heights



Inside widths



kabelschlepp.de

Divider system TS 0

Type	h_i mm	S_T mm	a_x mm	B_i mm	a_T min mm
0455	26	3	20	25	12.5
0455	26	3	20	38, 58, 78	19
0455	26	3	20	103	21.5
0455	26	3	20	130	25
0555	38	3	25	50 ... 150	25
0665	44	5	25	50 ... 175	25

The dividers are fixed at an interval of a_x .

For Type 0665, the divider system TS 1 with a central height subdivision ($S_H = 4$ mm) is also available.

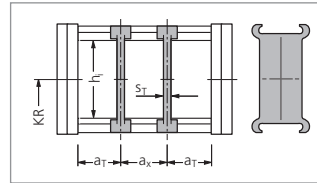

In the standard version, the divider systems are mounted on every second chain link.

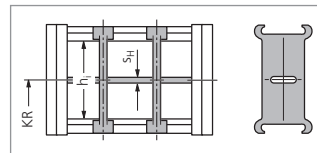

Font: +49 2762 4003-0

OnlineEngineer.de
KABELSCHLEPP
Cable Carrier Configurator

Types 0345, 0455, 0555 and 0665

Strain relief devices for plastic connectors

Inside
heights

20
—
44

Inside
widths

15
—
175

kabelschlepp.de

Fon: +49 2762 4003-0

Use our free
project planning service.

ZLK – A

Connecting elements with integrated strain relief combs on both sides (ZLK – A)



ZLK – L

Connecting elements with screw-on type strain relief combs (ZLK – L)

The strain relief combs are generally supplied with the connecting elements.

The combs are either clipped to the end connectors and bolted together with them, or screwed on at the desired intervals by using additional boreholes, behind the connecting elements.



Connection dimensions for Type 0345

Connecting elements with integrated strain relief combs on both sides

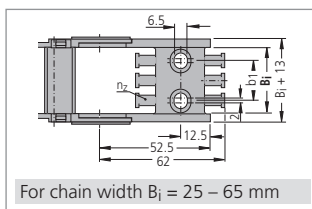
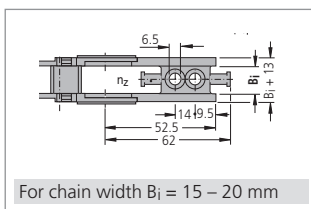
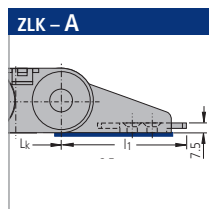

The dimensions of the fixed point and driver connections are identical.

Type	B_i	B_k	b_1	n_z
034515	15	28	–	1
034520	20	33	–	1
034525 *	25	38	13	2
034538	38	51	24	3
034550	50	63	36	4
034565	65	78	51	5

Dimensions in mm

* Type 034525 with 6.5 mm hole (not an elongated hole)
Connectors made of steel are available for carrier width $B_i = 90$ mm.

Types 0345, 0455, 0555 and 0665

Connection dimensions for Type 0455

Connecting elements with strain relief combs on both sides

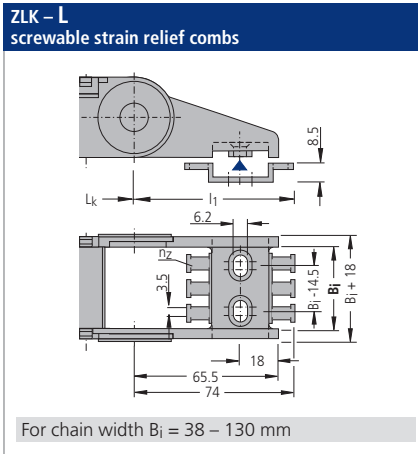
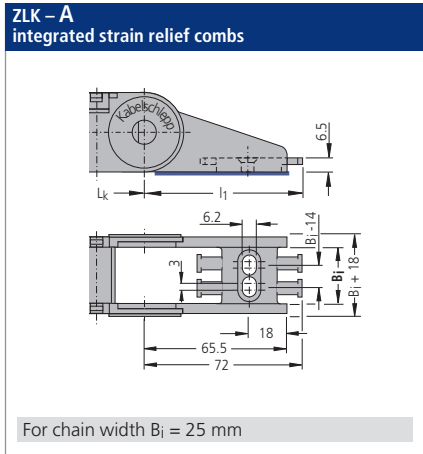

The dimensions of the fixed point and driver connections are identical.

Type	B_i	B_k	n_Z
045525	25	43	2
045538	38	56	3
045558	58	76	4
045578	78	96	6
0455103	103	121	8
0455130	130	148	10

Dimensions in mm

Connection dimensions for Type 0555

Connecting elements with strain relief combs on both sides

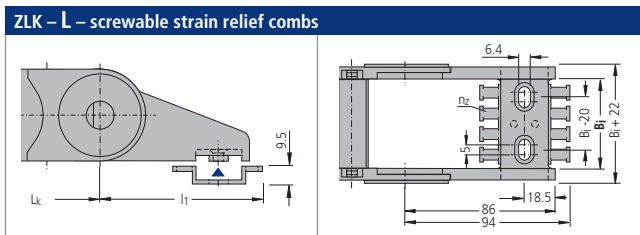

The dimensions of the fixed point and driver connections are identical.

Type	B_i	B_k	n_Z
055550	50	72	4
055575	75	97	6
0555100	100	122	8
0555125	125	147	10
0555150	150	172	12

Dimensions in mm

Inside heights



Inside widths



kabelschlepp.de

Font: +49 2762 4003-0

OnlineEngineer.de
with CONCEPT
Cable Center Configurator

Types 0345, 0455, 0555 and 0665

Connection dimensions for Type 0665

Connecting elements with strain relief combs on both sides

ZLK – L – screwable strain relief combs

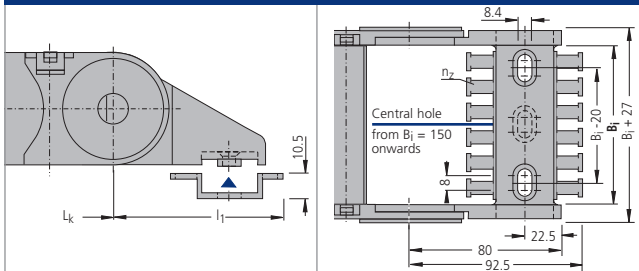

The dimensions of the fixed point and driver connections are identical.

Type	B_i	B_k	n_z
066550	50	77	4
066575	75	102	6
0665100	100	127	8
0665125	125	152	10
0665150	150	177	12
0665175	175	202	14
0665200	200	227	16
0665225	225	252	18
0665250	250	277	20

Dimensions in mm

Connection variants

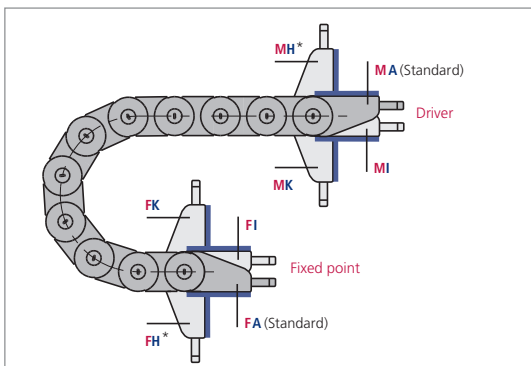

Connection point

- M** – Driver
- F** – Fixed point

Connection type

- A** – Threaded joint outside (standard)
- I** – Threaded joint inside
- H** – Threaded joint, rotated through 90° to the outside
- K** – Threaded joint, rotated through 90° to the inside

In the standard version, the connectors are mounted with the threaded joint outwards (**FA/MA**).

When ordering please specify the desired connection type (see ordering key on page 334).

The connection type can subsequently be altered simply by varying the connectors.

* not in the case of UNIFLEX design 060

Types 0345, 0455, 0555 and 0665

Connection dimensions

UMB (Universal Mounting Brackets) made of aluminium

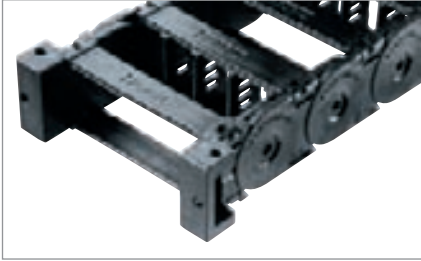

Universal connectors for connection above, below or at the front.

Inside heights



Inside widths

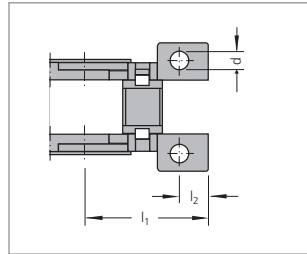
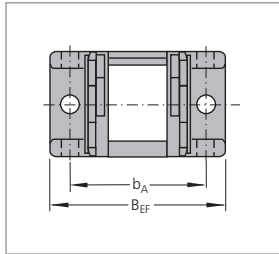
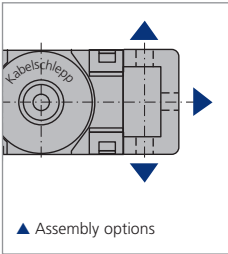

The dimensions of the fixed point and driver connections are identical.

Type	B_{EF}	b_A	l_1	l_2	d
0345	$B_i + 30$	$B_i + 20$	36	9	5.5
0455	$B_i + 30$	$B_i + 20$	47	10.5	5.5
0555	$B_i + 40$	$B_i + 28$	57	13.5	6.5
0665	$B_i + 44$	$B_i + 28$	68	14.5	8.5

Dimensions in mm

kabelschlepp.de

Font:
+49 2762 4003-0

OnlineEngineer.de
Kabelschlepp
Cable Carrier Configurator

Guide channels
► from page 295

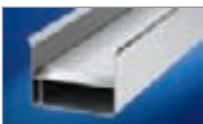

Strain relief devices
► from page 302



Cables for cable carrier systems
► from page 344





BASIC-LINE^{PLUS}

Solid plastic cable carrier with fixed chain widths

- Fast cable laying by simply pulling/pressing the cables in
- Ideal for short travel paths and high travel speeds



EasyTrax

Extremely quick cable laying, extra-stable thanks to two-component technology

page 110



PROTUM

Small, light cable carrier for unsupported applications

page 118



PROfile[®]

Cable carrier for short travel lengths and high travel speeds

page 124

EasyTrax
The power to innovate



EasyTrax

Extremely quick cable laying, extra-stable thanks to two-component technology

- Very fast cable laying by simply pressing in the cables
- Very high utilization factor due to flexible crossbars swivelling in the direction of the carrier and not in the cable space
- Stable chain construction
- Extensive unsupported length
- High torsional rigidity
- Very quiet thanks to integrated noise damping system

Chain links made of plastic

Extensive unsupported length

Connecting pieces with integrated strain relief comb



Every chain link is made of two different materials:

- Hard cable carrier body made of fiberglass-reinforced material
- Flexible lamella crossbars made of flexible special plastic

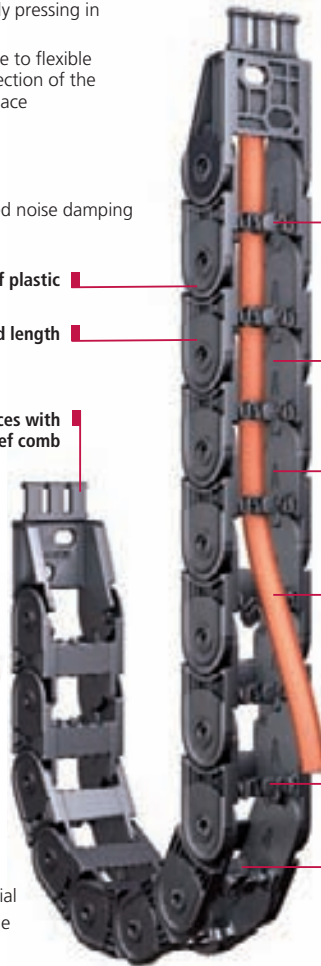

Intelligent 2-shot-design: hard cable carrier body, flexible lamella crossbars

Gentle on the cables – interior space without projecting edges

Very quiet thanks to internal noise damping system

Very fast cable laying by simply pressing in of the cables

Designs with inward or outward opening crossbars

Dividers for cable separation

Inside height



Inside widths



kabelschlepp.de

Font: +49 2762 4003-0

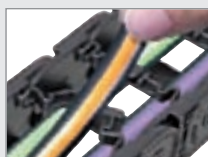

Quick and easy cable laying



Very high utilization factor



High side stability



Divider systems for reliable cable separation

Overview EasyTrax

Design 030:
Cables can be laid easily in the outer radius

Inside height



Inside widths

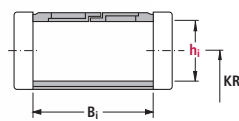

kabelschlepp.de

Type	h _i	B _i	Maximum travel length in m	Dynamics of unsupported arrangement		Page
				Travel speed v _{max} in m/s	Travel acceleration a _{max} in m/s ²	
ET 0320.030	18	15-50	80	10	50	114

Dimensions in mm

Design 040:
Cables can be laid easily in the inner radius

Fon: +49 2762 4003-0

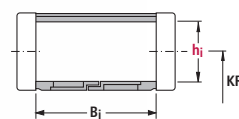

Type	h _i	B _i	Maximum travel length in m	Dynamics of unsupported arrangement		Page
				Travel speed v _{max} in m/s	Travel acceleration a _{max} in m/s ²	
ET 0320.040	18	15-50	80	10	50	114

Dimensions in mm

Use our free project planning service.

The 2-shot-technology of EasyTrax 0320

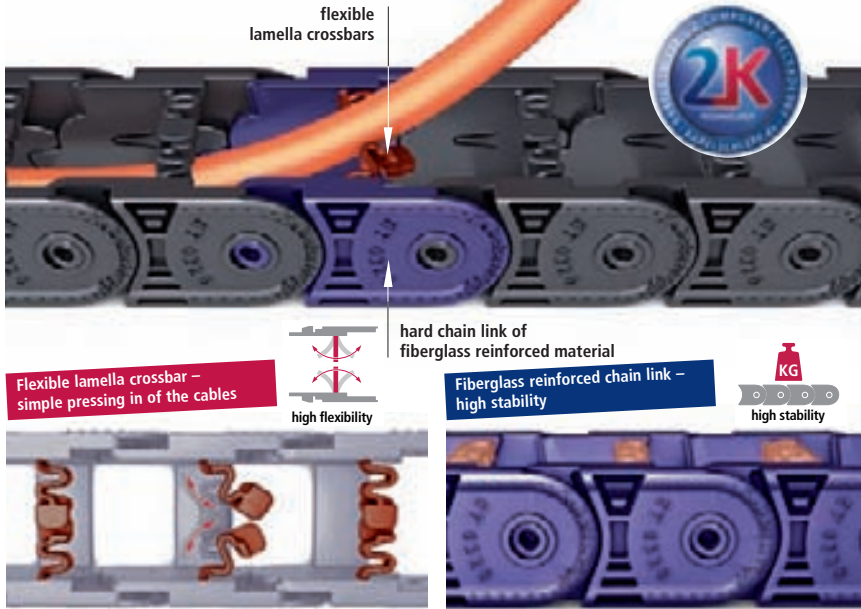

Inside height

18

Inside widths

15 - 50

kabelschlepp.de

High flexibility, high utilization factor – very quick cable laying thanks to simple pressing in of the cables.

The elastic material of the lamella crossbar significantly shortens the assembly times. The cable carrier is laid **simply by pressing the cables in**. The defined swivel direction in the direction of the cable allows a significantly **higher utilization factor** than in systems where cables are inserted into the cable space from above. The new crossbar design also allows the use of dividers for cable separation.



■ EasyTrax – very high utilization factor. Crossbar can be swiveled in the direction of the cable.

■ Unfavorable swivel direction of the crossbars in the cable space – cables already laid jam the crossbars.

High stability – long unsupported lengths thanks to fiberglass-reinforced material.

The use of fiberglass reinforced special plastic in the supporting area of the cable carrier makes it possible to nearly double the **unsupported length** compared to designs manufactured entirely from non-reinforced materials.

EasyTrax – long unsupported lengths.



Designs completely made of non-reinforced material – long unsupported lengths can only be implemented with sag.



Even greater side stability through locking in the stroke system

The stops are locked in the bend radius stop and pretension stop. This prevents snapping out in these areas and achieves very high lateral stability.



Font: +49 2762 4003-0

OnlineEngineer.de
KABELSCHLEPP
Cable Carrier Configurator

Type ET 0320

Inside height



Inside widths



Design 030

Outside: Simple pressing in of the cables

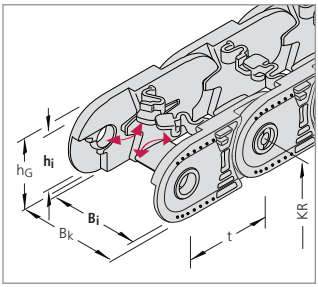

Design 040

Inside: Simple pressing in of the cables

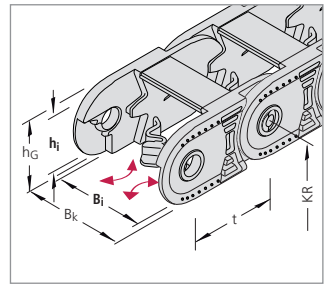

kabelschlepp.de

Dimensions and intrinsic chain weight

Type	h _i	h _G	Inside widths B _i				B _k
			Intrinsic chain weight				
ET 0320	18	25.5	15*	25	38	50*	B _i + 12
			0.18	0.27	0.41	0.54	

* on request

Dimensions in mm/Weights in kg/m

Bend radius and pitch

Bend radii KR mm						Pitch t = 32.0 mm
28	38	48	75	100*	125*	

* on request

Load diagram

for unsupported length L_f depending on the additional load

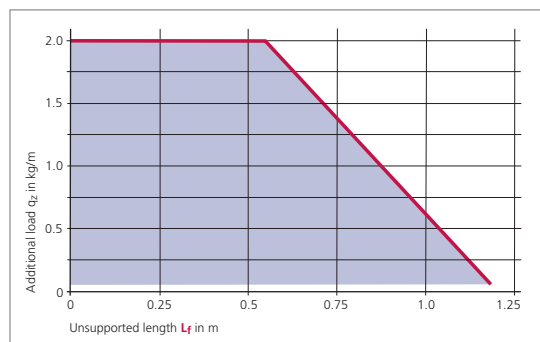

Unsupported length L_f

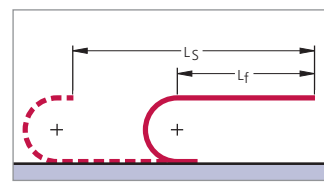

In the case of longer travel lengths, sag of the cable carriers is technically permissible depending on the application.

In a gliding arrangement, even longer travel lengths are possible (see page 295).

We are at your service to advise on these applications.

Fon: +49 2762 4003-0

Use our free project planning service.

Example of ordering

Cable carrier				Divider system		Connection
ET 0320	030	38	48	640	TS 0 / 1	FA/MA
Type	Design	Inside width B _i in mm	Bend radius KR in mm	Chain length L _k in mm (without connection)	Divider system	Number of dividers n _T
					Connection	Fixed point/Driver

Ordering divider systems:

Please state the designation of the divider system (TS 0, TS 1 ...) and the number of dividers. Possibly attach a sketch with the dimensions.

Type ET 0320

Divider system TS 0

Type	h_i mm	S_T mm
ET 0320	18	2

The dividers can be moved in the cross section.

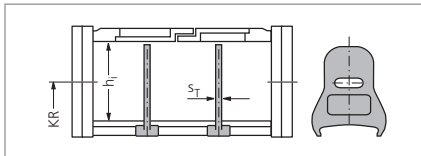

In the standard version, the divider systems are mounted on every second chain link.



Subject to change.

EasyTrax

Selection

BASIC LINE

BASIC LINEPLUS

Inside height

18

Inside widths

15

50

kabelschlepp.de

Font:

+49 2762 4003-0

OnlineEngineer.de
With Cable
 Concepts
 Cable Configurator

Type ET 0320

Connection dimensions

Plastic connectors with integrated strain relief

Inside height



Inside widths

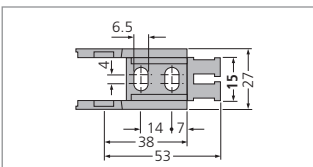
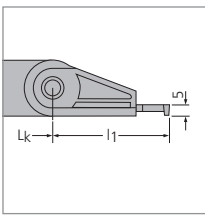

For chain width $B_i = 15$ mm

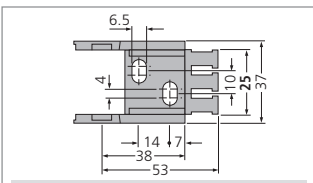

For chain width $B_i = 25$ mm

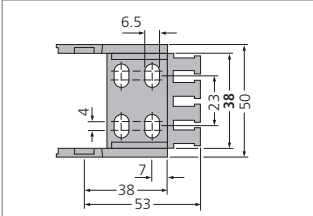

For chain width $B_i = 38$ mm

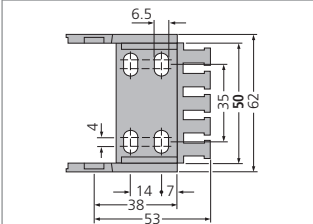

For chain width $B_i = 50$ mm

The dimensions of the fixed point and driver connections are identical.

Type	B_i	B_k	n_z
ET 0320.15	15	27	2
ET 0320.25	25	37	3
ET 0320.38	38	50	4
ET 0320.50	50	62	5

Dimensions in mm



Fon: +49 2762 4003-0

Use our free project planning service.

Mounting brackets without a strain relief comb are also available – please contact us.



Type ET 0320

Connection variants

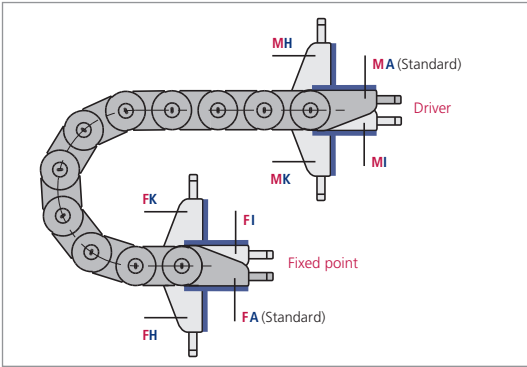

In the standard version, the connectors are mounted with the threaded joint outwards (**FA/MA**).

When ordering please specify the desired connection type (see ordering key on page 335).

The connection type can subsequently be altered simply by varying the connectors.

Connection point

- M** – Driver
- F** – Fixed point

Connection type

- A** – Threaded joint outside (standard)
- I** – Threaded joint inside
- H** – Threaded joint, rotated through 90° to the outside
- K** – Threaded joint, rotated through 90° to the inside



Inside height



Inside widths



kabelschlepp.de

Font:
+49 2762 4003-0

OnlineEngineer.de
with CableCarrier
Cable Carrier Configurator

Guide channels
▶ from page 295

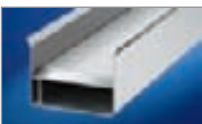

Strain relief devices
▶ from page 302



Cables for cable carrier systems
▶ from page 344



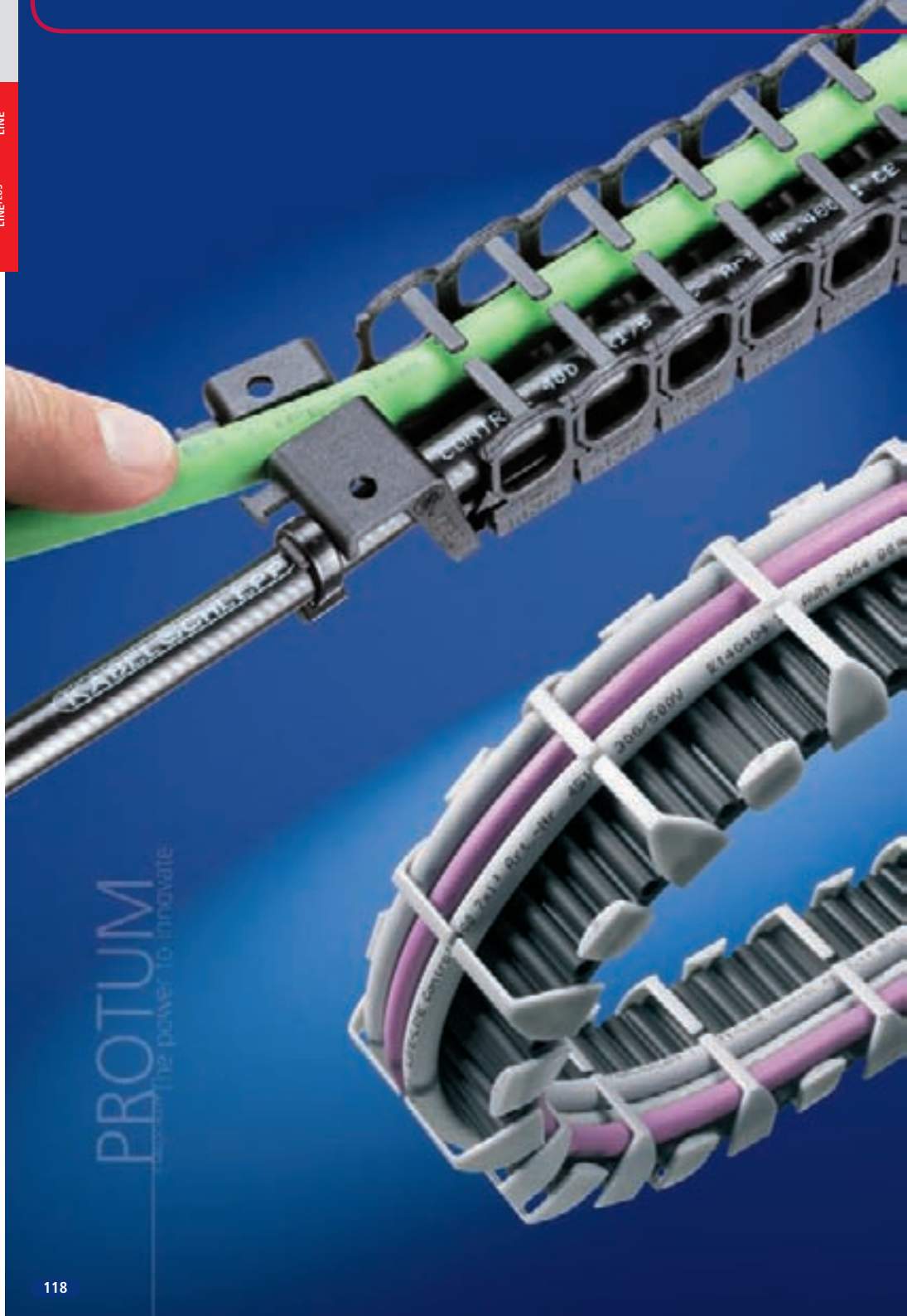

PROTUM
The power to innovate

PROTUM

Small, light cable carrier for unsupported applications

- Low vibration and quiet operation
- Optimal for short travel lengths and high travel speeds
- Gentle on the cables, since there is almost no polygon effect

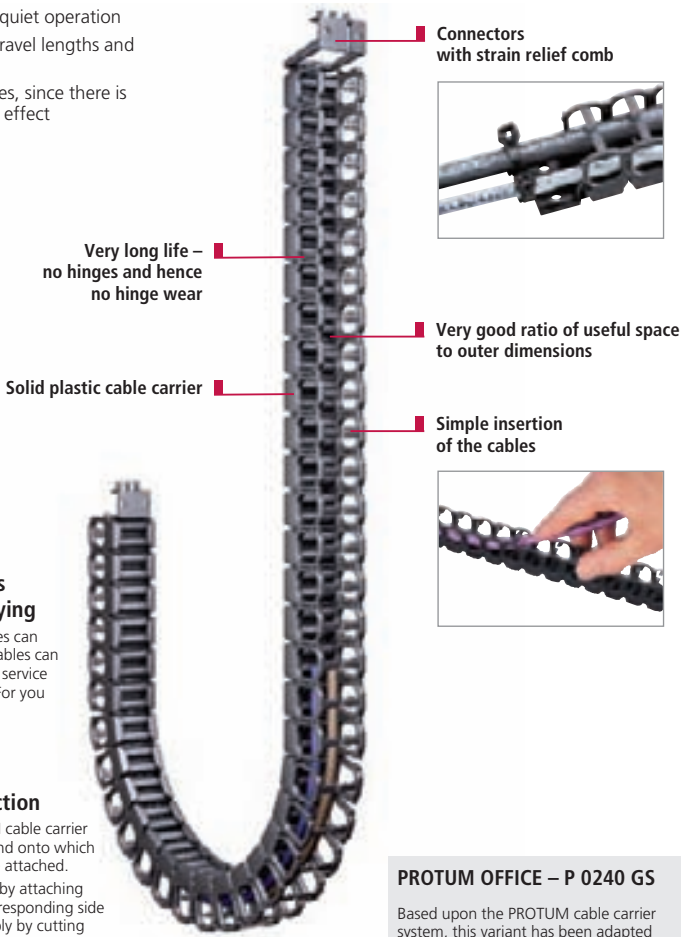

Very long life – no hinges and hence no hinge wear

Solid plastic cable carrier

Connectors with strain relief comb



Very good ratio of useful space to outer dimensions

Simple insertion of the cables



Inside heights



Inside widths



Less expense – lower costs thanks to simple cable laying

Even pre-assembled cables can simply be inserted. The cables can easily be changed during service and maintenance work. For you this means lower costs.

The basic construction

The basis of the PROTUM cable carrier system is an extruded band onto which lightweight side parts are attached. It can easily be extended by attaching additional bands and corresponding side parts and shortened simply by cutting through the band with a knife.

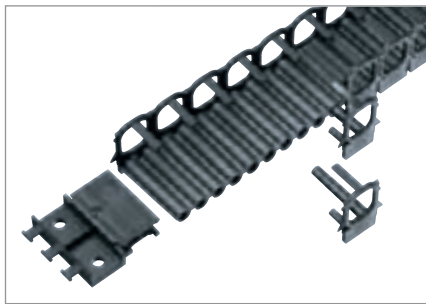

PROTUM OFFICE – P 0240 GS

Based upon the PROTUM cable carrier system, this variant has been adapted for use in office areas.

The inner width and the possibility of double occupancy provide sufficient space for cables in office areas, i.e. for telecommunications, energy and data cables.

The link-free construction also serves as a design feature, with silver-grey, elegant-looking side walls.

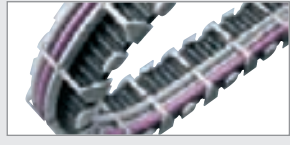

kabelschlepp.de

Font: +49 2762 4003-0

OnlineEngineer.de
KABELSCHLEPP
Cable Carrier Configurator

Types P 0160, P 0240 and P 0300

Inside heights



Inside widths

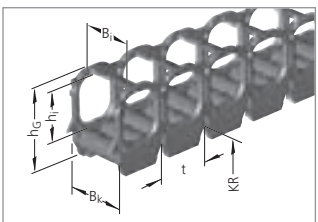

Dimensions and intrinsic chain weight

Type	h _i	h _G	Inside widths B _i			B _k	For cable-Ø
			Intrinsic chain weight				
P 0160	15	25	15	20	30	B _i + 4	10
			0.14	0.16	0.21		
P 0240	20	31	20	30	40	B _i + 5	15
			0.18	0.22	0.27		
P 0300	25	43	25	35	45	B _i + 6	20
			0.32	0.39	0.47		

Dimensions in mm/Weights in kg/m

Bend radius and pitch

Type	Bend radii KR mm			
P 0160	18	28	38	48
P 0240	27	42	57	72
P 0300	34	53	72	90

Pitch:
 P 0160: t = 16 mm
 P 0240: t = 24 mm
 P 0300: t = 30 mm

Load diagram

for unsupported length L_f depending on the additional load

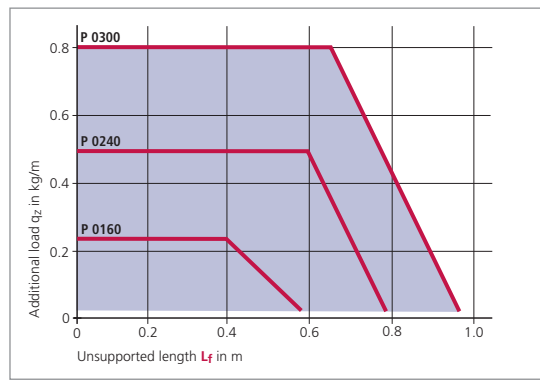

Unsupported length L_f

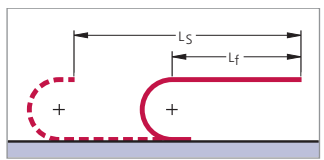

In the case of longer travel lengths, sag of the cable carriers is technically permissible depending on the application.

We are at your service to advise on these applications.

Example of ordering

Cable carrier
P 0240 - **010** - **30** - **42** - **380** Connection **FA/MA**

Type Design* Inside width B_i in mm Bend radius KR in mm Chain length L_k in mm (without connection) Connection Fixed point/Driver

* Design 010 (simple insertion of the cables)

kabelschlepp.de

Fon: +49 2762 4003-0

Use our free project planning service.

Types P 0160, P 0240 and P 0300

Plastic connectors with integrated strain relief

Connection dimensions – connection on the outside

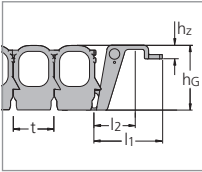

The dimensions of the fixed point and driver connections are identical.

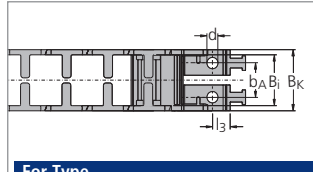

For Type

P 0160: $B_j = 15, 20$ P 0240: $B_j = 20$

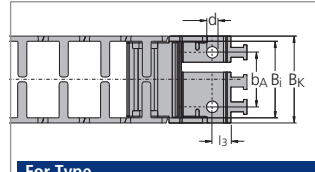

For Type

P 0160: $B_j = 30$ P 0240: $B_j = 30, 40$

Inside heights

15
—
25

Inside widths

15
—
45

Type	B_j	B_k	b_A	d	l_1	l_2	l_3	h_z	h_G
P 0160	15	$B_j + 4$	11	4.2	33.6	19.5	7.5	6.5	25
	20		14						
	30		22						
P 0240	20	$B_j + 5$	14	4.2	33.6	19.5	7.5	6.5	31
	30		22						
	40		32						

Plastic connecting elements with strain relief combs

Dimensions in mm

Connection dimensions – connection on the inside

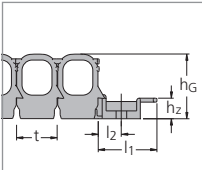

The dimensions of the fixed point and driver connections are identical.

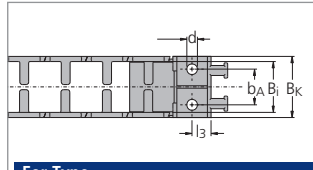

For Type

P 0160: $B_j = 15, 20$ P 0240: $B_j = 20$
P 0300: $B_j = 25, 35$

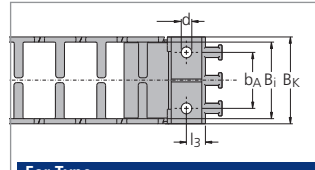

For Type

P 0160: $B_j = 30$ P 0240: $B_j = 30, 40$
P 0300: $B_j = 45$

Type	B_j	B_k	b_A	d	l_1	l_2	l_3	h_z	h_G
P 0160	15	$B_j + 4$	11	4.2	23	7.5	7.5	8	25
	20		14						
	30		22						
P 0240	20	$B_j + 5$	11	4.2	23	7.5	7.5	8	31
	30		22						
	40		32						
P 0300	25	$B_j + 6$	14	6.2	40	16	14	15	43
	35		17						
	45		22						

Plastic connecting elements with strain relief combs

Dimensions in mm

Connection variants

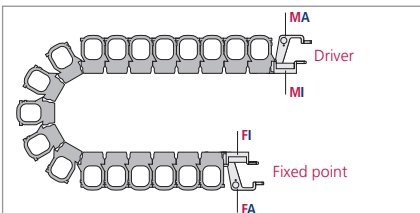

Connection point

- M** – Driver
- F** – Fixed point

Connection type

- I** – Threaded joint, inside
- A** – Threaded joint, outside

Subject to change.

kabelschlepp.de

Fon: +49 2762 4003-0

OnlineEngineer.de
with Concepts
Cable Chain Configurator

PROTUM OFFICE – P 0240 GS

Based on the PROTUM cable carrier system, this variant has been adapted for use in office areas. The inside width and the possibility of double occupancy provide sufficient space for cables in office areas, i.e. for telecommunications, energy and data cables. The link-free construction also serves as a design feature, with silver-grey, elegant-looking side walls.



Inside heights



Inside widths



kabelschlepp.de

Dimensions and intrinsic chain weight

Type	h_i	h_G	B_i	B_k	For cable-Ø
P 0240 GS	10	23	50	54	3 – 9

Dimensions in mm

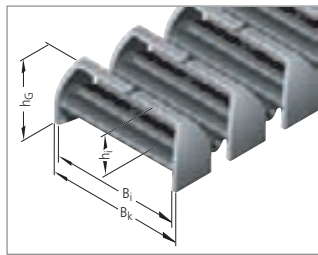

Fon: +49 2762 4003-0

Connectors

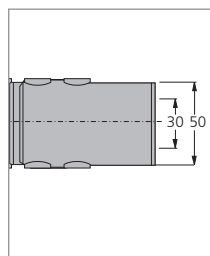
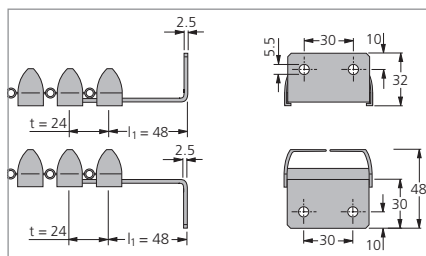
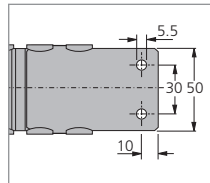
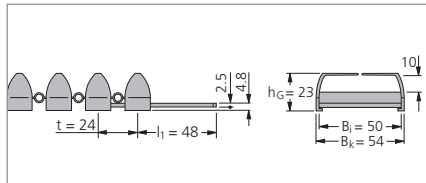
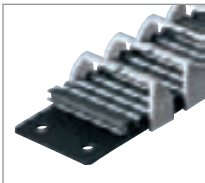

Use our free project planning service.

PROTUM OFFICE – P 0240 GS

Laying on both sides

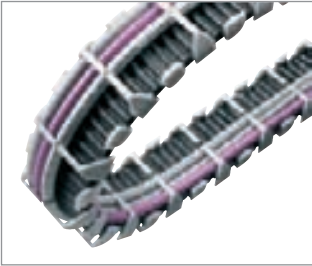

■ Where more of space is needed, the take-up capacity can be doubled by laying the cables on both sides. In this case every second side-part is simply attached the other way round.

Fast laying

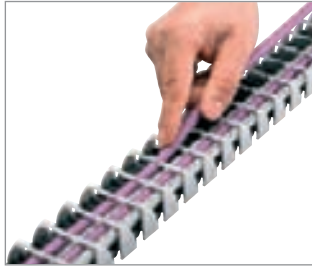

■ Simple insertion of the cables.

Inside heights



Inside widths



Application examples



■ Photographs: Haworth Büroeinrichtungen GmbH

kabelschlepp.de

Font: +49 2762 4003-0

OnlineEngineer.de
 The Cable
 Cable Center Configurator

PROFILE®
The power to innovate



PROfile®

Cable carrier for short travel lengths and high travel speeds

- Low vibration and quiet operation
- Clean-room compatible owing to low-wear construction and the concomitant minimal particle emission
- Pre-assembled cables can also be inserted easily. And this means: less costs!

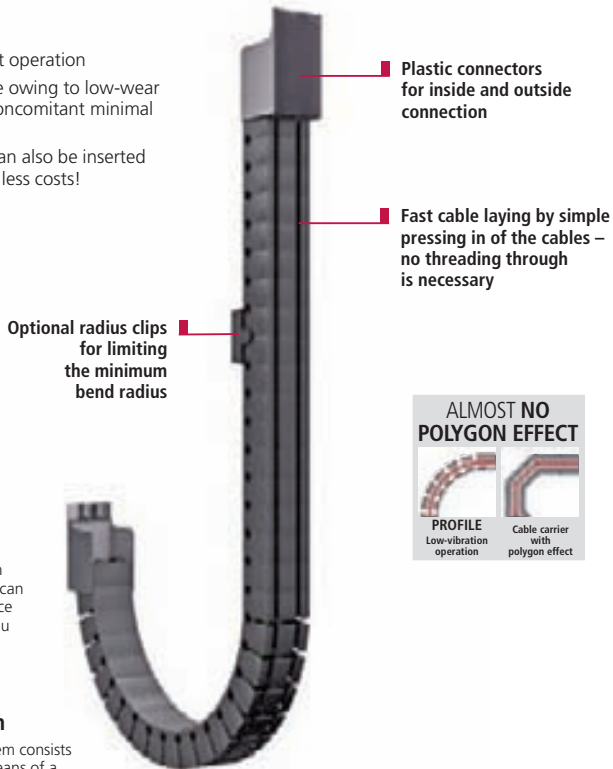

Inside heights



Inside widths



kabelschlepp.de

Font: +49 2762 4003-0

OnlineEngineer.de
with CONCEPT Cable Carrier Configurator

Less expense – lower costs thanks to simple cable laying

Even pre-assembled cables can simply be inserted. The cables can easily be changed during service and maintenance work. For you this means lower costs.

The basic construction

The PROfile® cable carrier system consists of extruded profile bars. By means of a special process, they become able to bend in one direction and form an almost perfectly round circular shape. Since there are no hinges, the system is very durable and quiet. Operation is almost vibration-free. If there is not sufficient space in one module for laying the cables, several modules can be combined into a system. Plastic end connectors of plastic are available for fastening.

ALMOST NO POLYGON EFFECT

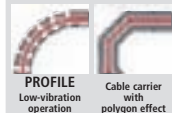

Different standard and special models:
Enclosed modules for small cable diameters
outside or inside open modules for ribbon cables

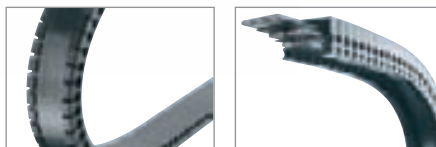

Very long service life – tested for several million movement cycles

The life of the PROfile® system is primarily influenced by the ambient temperature and the bend radius. The diagram shows the extremely long life of PROfile® systems.

Example: At a temperature of -25 °C and a bend radius of 175 mm, the PROfile® system can achieve about 40 million cycles.

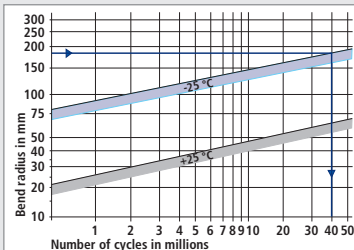

PROfile® – standard modules

Dimensions and module weights

Inside height

34

Inside widths

24
64

Module	h _i	h _M	B _M	A	C	Cable-Ø		Intrinsic module weight
						min.	max.	
EM-1212	34	40	32	12	4	6	11	0.303 kg/m
EM-1717	34	40	42	17	4	8	16	0.353 kg/m
EM-2222	34	40	52	22	7	14	21	0.430 kg/m
EM-2727	34	40	62	27	10	17	26	0.475 kg/m
EM-3232	34	40	72	32	15	20	30	0.521 kg/m

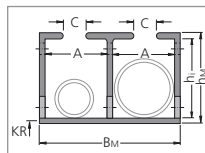

Dimensions in mm

Bend radius and pitch

The minimal bend radius of the extrusion profile bars is determined by their intrinsic rigidity. **PROfile®** Standard modules can be fitted with radius clips to limit the minimum bend radius (see table).

In individual modules, the radius clips are placed across the entire length of the module; in module combinations, only on the outer modules.

Module	Bend radii KR mm				
	75	100	150	200	250
EM-1212	75	100	150	200	250
EM-1717	75	100	150	200	250
EM-2222	75	100	150	200	250
EM-2727	–	100	150	200	250
EM-3232	–	100	150	200	250

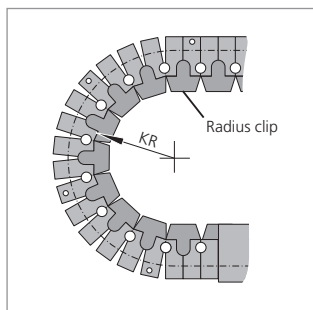

Pitch t = 20 mm



Part numbers for ordering **radius clips**

Bend radius	Module EM-1212	Module EM-1717	Module EM-2222	Module EM-2727	Module EM-3232
75	EC-075032	EC-075042	EC-075052	–	–
100	EC-100032	EC-100042	EC-100052	EC-100062	EC-100072
150	EC-150032	EC-150042	EC-150052	EC-150062	EC-150072
200	EC-200032	EC-200042	EC-200052	EC-200062	EC-200072
250	EC-250032	EC-250042	EC-250052	EC-250062	EC-250072

Number of radius clips required:

Dimensions in mm

Single module: 25 pieces/m / module combination: 2 x 25 pieces/m

Use our free
project planning service.

Fon:

+49 2762 4003-0

PROfile® – standard modules

Module combinations

PROfile® Standard modules can be combined with one another as required. For this purpose, the module side walls are connected by joining rivets.

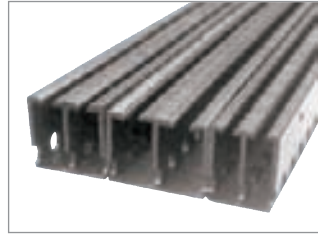
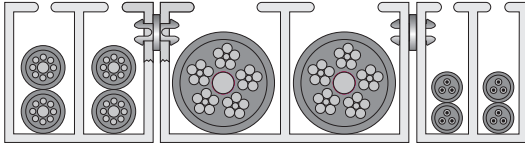

Inside height



Inside widths



Total width of the module combinations B_G

$$B_G = \sum B_M + [(n_M - 1) \times 3] \quad [\text{mm}]$$

Number of joining rivets n_N

$$n_N = (n_M - 1) \times L_K [m] \times 10$$

B_M = Width of the module (see table above)

n_M = Number of modules

L_K = Length of the module (see page 41)

kabelschlepp.de

Example of ordering

Cable carrier

EM-3232 - 460

Connection

FA/MA

Module designation

Module length L_K in mm (with-out connection)

Connection Fixed point/Driver

Ordering special modules and accessories – see page 336.

Font: +49 2762 4003-0

OnlineEngineer.de
With Cable Carrier Configurator

PROfile® – standard modules

Plastic connectors

Connection dimensions EM-1212, EM-1717, EM-2222, EM-2727 and EM-3232

At the driver and the fixed point, the single unit connecting elements are snapped into the boreholes of the module. The module length taken up by the connecting element is 50 mm.

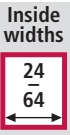
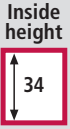

kabelschlepp.de

Fon: +49 2762 4003-0

Connecting element for connecting surface, on the outside

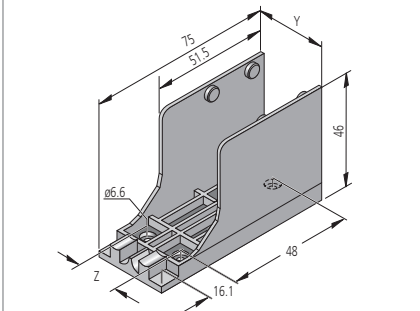

Connecting element for connecting surface, on the inside

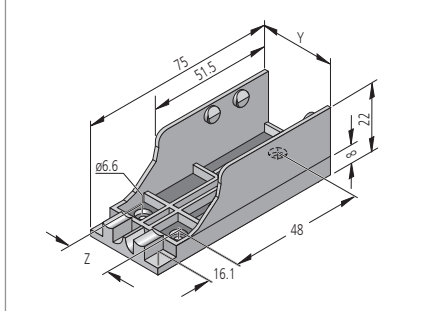

Module	EM-1212	EM-1717	EM-2222	EM-2727	EM-3232
Y	36	46	56	66	75.5
Z	18	20	30	40	50

Dimensions in mm

Connection variants

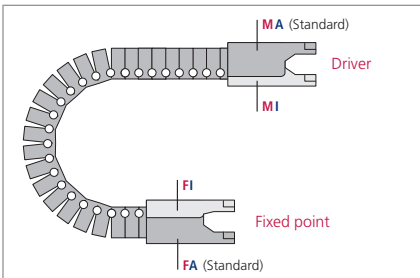

Connection point

- M** – Driver
- F** – Fixed point

Connection type

- I** – Threaded joint, inside
- A** – Threaded joint, outside

Please specify the desired connection variant when placing your order.
 For modules EM-S15, EM-S45.20 and EM-S45 as well as EM-S67 and QM-45.23, no connecting elements are required. These can be screwed on directly at the driver and the fixed point.

PROfile® – special modules

Enclosed special module with small dimensions

EM-S15

Module	h _i	h _M	B _M	A	Cable width max.	Intrinsic module weight
EM-S15	6	7.5	17.5	15	14	0.024 kg/m

Pitch t = 6.75 mm

Dimensions in mm

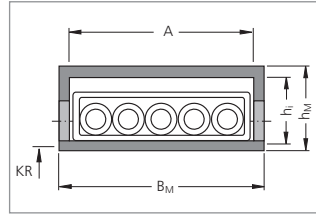

Inside heights



Inside widths



Open special module for ribbon cables

Special module open on the outside

Module	h _i	h _M	B _M	A	C	Cable width max.	Intrinsic module weight
EM-S43.20	20	23.5	48	43	28	42	0.153 kg/m
EM-S45.20	20	23.5	49	45	33	44	0.135 kg/m
EM-S45.16.5	16.5	20	49	45	33	44	0.130 kg/m
EM-S67.11	11	15	72	67	50	65	0.174 kg/m

Pitch t = 13.5 mm

Dimensions in mm

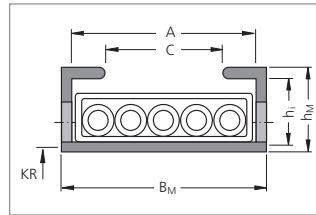

kabelschlepp.de

Font: +49 2762 4003-0

Special module open on the inside

Module	h _i	h _M	B _M	A	C	Cable width max.	Intrinsic module weight
QM-45.23	23.5	38	50	45	30	44	0.320 kg/m

Pitch t = 15 mm

Dimensions in mm

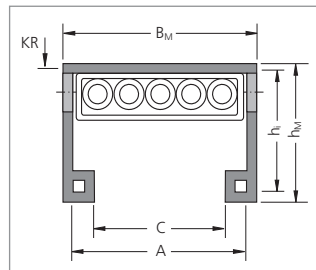

OnlineEngineer.de
KABELSCHLEPP
Cable Center Configurator

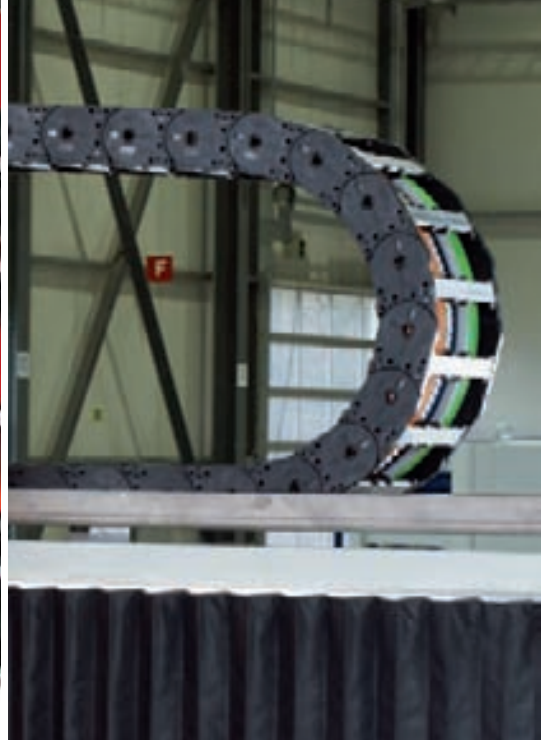

VARIO-LINE

Cable carriers with variable chain widths

- Aluminium or plastic stays
- Inside and outside easy and quick to open
- Light, robust or link-free series – a suitable solution for every application



K Series

page 132

Cost-effective, robust cable carrier
also suitable for large additional loads



MASTER Series

page 148

Quiet and weight-optimized
cable carriers



M Series

page 158

Multivariable cable carrier
with extensive accessories and stay variants



XL Series

page 180

Cable carrier with large inside height



QUANTUM

page 186

Link-free cable carrier – light, extremely quiet
and low vibration for high speeds and accelerations



TKR 0200

page 194

Extremely quiet and low-vibration
for highly dynamic applications



k series
The power to innovate

K Series

Cost-effective, robust cable carrier – also suitable for large additional loads

■ TÜV design approved in accordance with 2PFG 1036/10.97

Inside heights



Inside widths



kabelschlepp.de

Font: +49 2762 4003-0

OnlineEngineer.de
KABELSCHLEPP
Cable Carrier Configurator

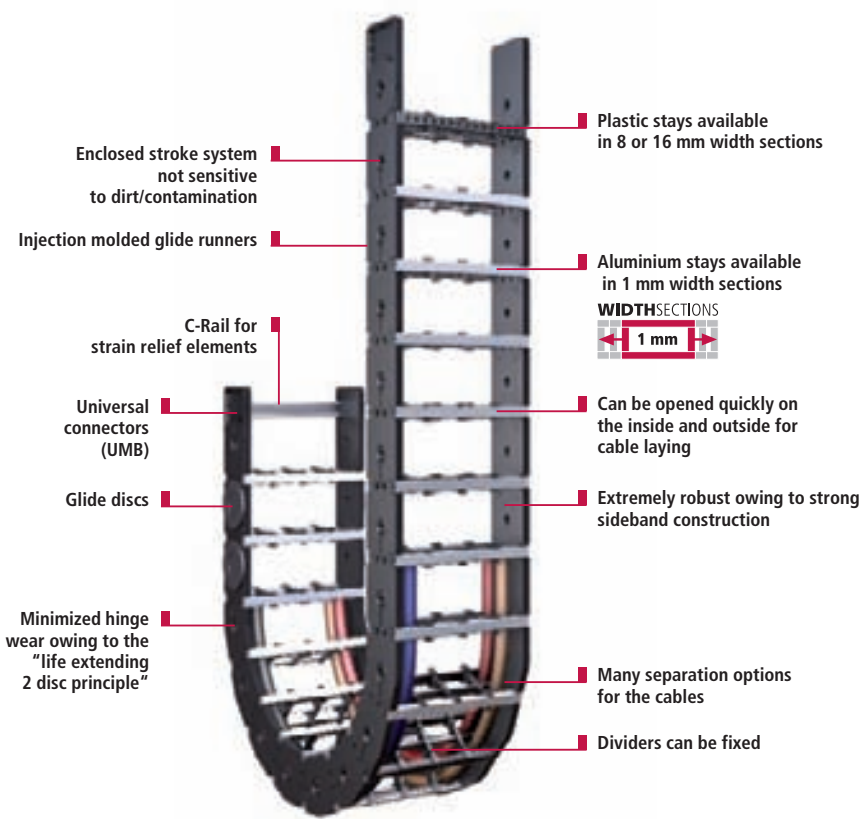

Minimized hinge wear owing to the "life extending 2 disc principle"



Glide discs for long service life for applications where the carrier is rotated through 90°



Injection molded glide runners for long service life in gliding arrangement

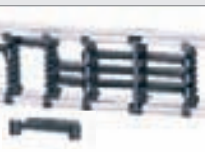

Many separation options for the cables

Subject to change.

Overview K Series

Type KC with aluminium stays

Inside heights



Inside widths



WIDTH SECTIONS



- Available in 1 mm width sections



Type	h _i	B _i	Maximum travel length in m	Dynamics of unsupported arrangement		Page
				Travel speed v _{max} in m/s	Travel acceleration a _{max} in m/s ²	
KC 0650	38	75-400	220	8	40	135
KC 0900	58	100-500	260	6	30	135

Dimensions in mm

kabelschlepp.de

Fon: +49 2762 4003-0

Type KE with plastic stays

- Available in 8 or 16 mm width sections

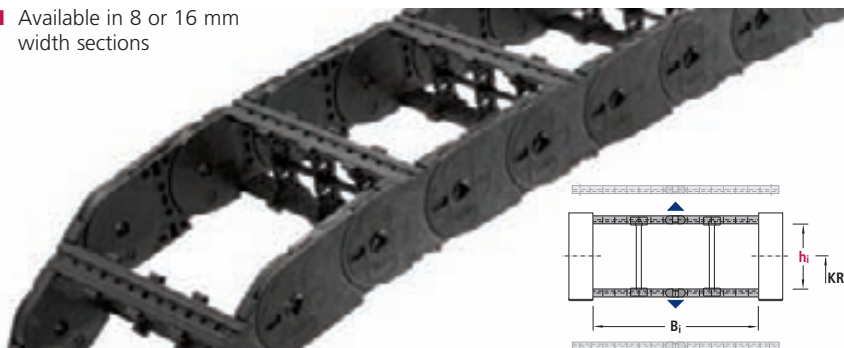

Type	h _i	B _i	Maximum travel length in m	Dynamics of unsupported arrangement		Page
				Travel speed v _{max} in m/s	Travel acceleration a _{max} in m/s ²	
KE 0650	42	68-260	220	8	40	142
KE 0900	58	81-561	260	6	30	142

Dimensions in mm

Use our free project planning service.

Type KC

with aluminium stays

- Available in 1 mm width sections (standard widths available ex-stock)

WIDTH SECTIONS



Inside heights



Inside widths



kabelschlepp.de

Font: +49 2762 4003-0

OnlineEngineer.de
 The Cable Carrier Configurator

Stay variants

Frame stay RS

Standard design –
Types 0650 and 0900

For lightweight to medium loads.

Opening options:

Outside/inside: the cable carrier can be opened quickly and easily simply by rotating the stays through 90°.

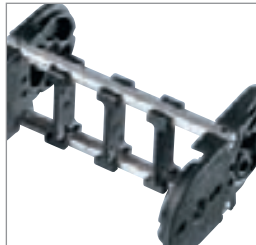

Frame stay RV

Reinforced design –
Type 0900

For medium to heavy loads and for large chain widths.

Opening options:

Outside/inside: the cable carrier can be opened quickly and easily simply by rotating the stays through 90°.

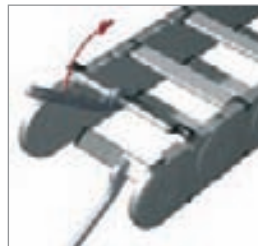
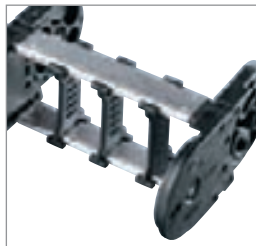

Stay arrangement

Standard: on every 2nd chain link

Stays can be fitted on every chain link, please specify when placing your order.

Types KC 0650 and 0900

Dimensions and intrinsic chain weight

Inside heights



Inside widths



Type	Stay variant	h _i	h _G	B _i min	q _k min	B _i max	q _k max	B _k
KC 0650	RS	38	57.5	75	1.87	400	3.60	B _i + 28
KC 0900	RS	58	78.5	100	2.80	400	5.80	B _i + 31
KC 0900	RV	58	78.5	100	3.20	500	7.00	B _i + 31

Dimensions in mm/Weights in kg/m

Standard widths in 25 mm steps available **ex-stock**.

Type 0650: B_i = 75, 100, 125, 150 ... 400

Type 0900: B_i = 100, 125, 150, 175 ... 500

WIDTH SECTIONS

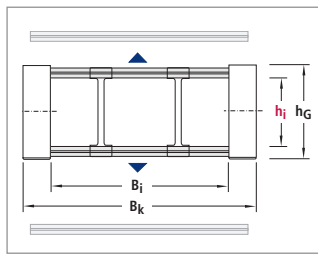

Bend radius and pitch

Type	Bend radii KR mm					
KC 0650	75	115	145	175	220	300
KC 0900	130	150	190	245	300	385

Pitch:

KC 0650: t = 65 mm

KC 0900: t = 90 mm

Load diagram

for unsupported length L_f depending on the additional load

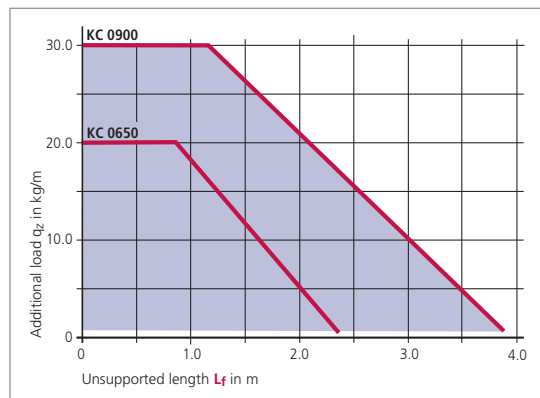

Unsupported length L_f

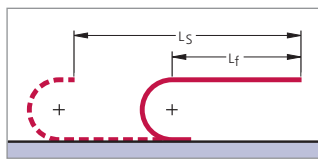

In the case of longer travel lengths, sag of the cable carriers is technically permissible depending on the application.

In a gliding arrangement, even longer travel lengths are possible (see page 295).

We are at your service to advise on these applications.

Fon: +49 2762 4003-0

Use our free project planning service.

Example of ordering

Cable carrier: **KC 0900** - **225** - **RV** - **150** - **1890**

Type: Inside width B_i in mm | Stay variant | Bend radius KR in mm | Chain length L_k in mm (without connection)

Divider system: **TS 0** / **4**

Connection: **FU/MU**

Divider system: Divider system | Number of dividers n_T | Connection: Fixed point/Driver

Ordering divider systems:

Please state the designation of the divider system (TS 0, TS 1 ...) and the number of dividers. Possibly attach a sketch with the dimensions.

Types KC 0650 and 0900

Divider system TS 0

Type	Stay variant	h _i mm	S _T mm	a _T min mm	a _x min mm
KC 0650	RS	38	3	6,5	13
KC 0900	RS	58	4	7	14
KC 0900	RV	58	4	7	14

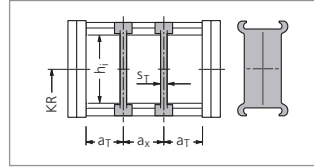

In the standard version, the divider systems are mounted on every second chain link.

Inside heights



Inside widths



Divider system TS 1 with continuous height subdivision made of aluminium

Type	Stay variant	h _i mm	S _T mm	a _T min mm	a _x min mm	S _H mm	h ₁ mm	h ₂ mm
KC 0650	RS	38	3	6,5	13	4	15	–
KC 0900	RS	58	4	7	14	4	30	–
KC 0900	RV	58	4	7	14	4	15	30

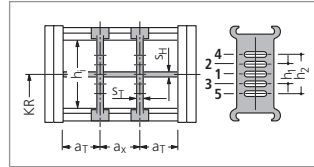

In the standard version, the divider systems are mounted on every second chain link.

Divider system TS 3 with section subdivision, partitions made of plastic

Type	Stay variant	h _i mm	S _T mm	a _T min mm	a _x min mm	S _H mm	h ₁ mm	h ₂ mm	h ₃ mm
KC 0650	RS	38	8	4	16*	4	14	28	–
KC 0900	RV	58	8	4	16*	4	14	28	42

The dividers are fixed by the partitions, * When using plastic partitions the complete divider system is movable.

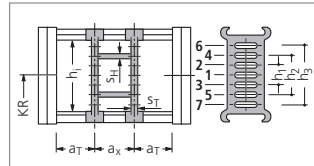

In the standard version, the divider systems are mounted on every second chain link.

kabelschlepp.de

Fon: +49 2762 4003-0

Dimensions of the plastic partitions for TS 3

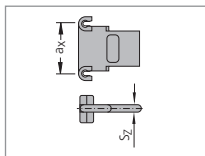

S _Z	a _x (center-to-center dividers)									
4	16	18	23	28	32	33	38	43	48	58
	64	68	78	80	88	96	112	128	144	160
	176	192	208	–	–	–	–	–	–	–

Dimensions in mm

Aluminium partitions in 1 mm width sections are also available.

When using partitions with a_x > 112 mm there should be an additional central support with a twin divider.

Thickness of the twin dividers: KC 0650 S_T = 3 mm, KC 0900 S_T = 4 mm
Twin dividers are designed for subsequent fitting in the partition system.

Inside heights



Inside widths



kabelschlepp.de

Fon: +49 2762 4003-0

Use our free project planning service.

Types KC 0650 and 0900

Glide discs and injection molded glide runners

Glide discs

If the cable carrier is arranged rotated "through 90" (gliding on the outer side of the chain band), the glide discs attached to the side optimize the friction and wear conditions.

Determining the chain width with glide discs on both chain bands:

KC 0650: $B_{EF'} = B_i + 36 \text{ mm}$
 KC 0900: $B_{EF'} = B_i + 45 \text{ mm}$

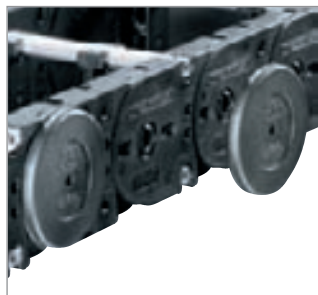

Injection molded glide runners

guarantee the long service life of the cable carrier in the case of long travel lengths and large additional loads.



Minimized hinge wear owing to the "life extending 2 disc principle"

In the K Series, the push and pull forces are transmitted via the optimum link design for this purpose.

As a result link wear is reduced to a minimum and the life of the cable carrier is considerably lengthened.

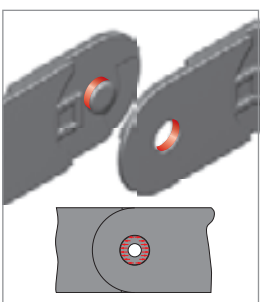

■ Force transmission with a pin-hole joint

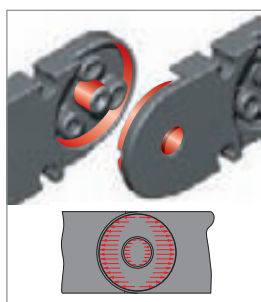

■ Force transmission with the "life extending 2 disc principle"

Types KC 0650 and 0900

UMB (Universal Mounting Brackets) made of plastic – Type KC 0650

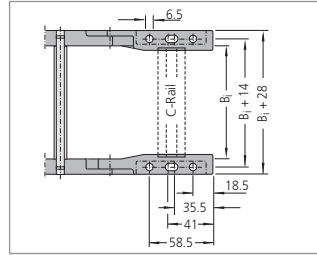
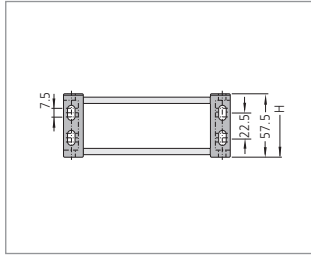
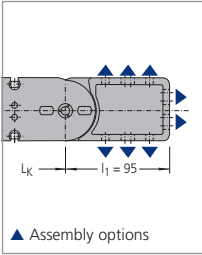

Inside heights

38
58

Inside widths

75
500

The dimensions of the fixed point and driver connections are identical.

End connectors made of steel plate available on request.

Optional C-rails and strain relief elements for cables can be found on the following pages.

When ordering please specify the connection type FU/MU (see ordering key on page 337).



kabelschlepp.de

UMB (Universal Mounting Brackets) made of plastic – Type KC 0900

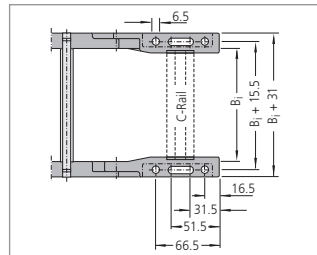
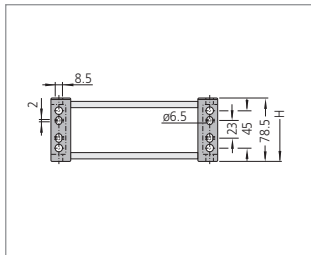
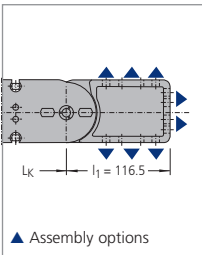

Font:

+49 2762 4003-0

The dimensions of the fixed point and driver connections are identical.

End connectors made of steel plate available on request.

Optional C-rails and strain relief elements for cables can be found on the following pages.

When ordering please specify the connection type FU/MU (see ordering key on page 337).

Guide channels
► from page 295

Strain relief devices
► from page 302

Cables for cable carrier systems
► from page 344

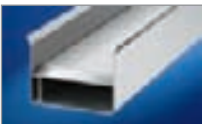

Types KC 0650 and 0900

Strain relief devices

Strain relief combs made of plastic on both sides (KC 0650)

The cables can be fixed securely and simply using the **optional strain relief combs**.

The strain relief combs are installed between the UMBs, and do not need to be bolted on separately or mounted on a C-Rail.

Please state on the order whether strain relief combs are needed.

Inside heights

38
-
58

Inside widths

75
-
500

kabelschlepp.de

Fon:
+49 2762 4003-0

Use our free
project planning service.

140



■ Universal mounting bracket with strain relief comb



■ Both-sided strain relief comb



■ Fixing in the UMB.

Type	B _i mm	n _z
KC 0650	78	5
KC 0650	83	5
KC 0650	103	7
KC 0650	108	7
KC 0650	123	8
KC 0650	128	9
KC 0650	133	9
KC 0650	153	11
KC 0650	158	11
KC 0650	178	13
KC 0650	183	13
KC 0650	203	15
KC 0650	208	15
KC 0650	233*	17
KC 0650	258*	19

n_z = Number of teeth on one side of the comb

* on request

Types KC 0650 and 0900

Strain relief devices

C-rails for LineFix bracket clamps, SZL strain reliefs and clamps

The optional C-rails are fixed by means of the universal mounting brackets and do not have to be screwed separately.

Please state in your order whether C-rails are needed.



■ Universal mounting bracket with C-rail

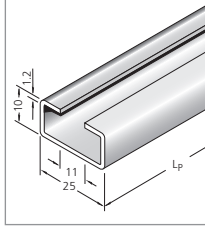

■ **KC 0650:**
Integratable C-rail
25 x 10 mm,
slit width 11 mm,
material steel,
Item-No. 3931

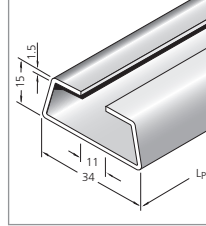

■ **KC 0900:**
Integratable C-rail
34 x 15 mm,
slit width 11 mm,
material steel,
Item-No. 3935

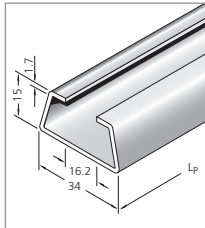

■ **KC 0900:**
Integratable C-rail
34 x 15 mm,
slit width 16 – 17 mm,
material aluminium,
Item-No. 3926,
material steel,
Item-No. 3932

Inside heights



Inside widths



kabelschlepp.de

Font:
+49 2762 4003-0

Our LineFix strain reliefs are optimally suited for the C-rails. (LineFix bracket clamps and other strain relief devices – see Accessories chapter, from page 302 onwards).



■ C-rail with LineFix strain relief

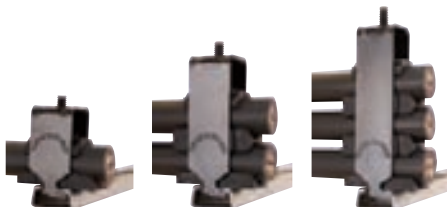

OnlineEngineer.de
KABELSCHLEPP
Cable Center Configurator

Inside
heights42
-
58Inside
widths68
-
561

kabelschlepp.de

Fon:
+49 2762 4003-0Use our free
project planning service.

Type KE

with plastic stays

- KE 0650
available in 8 mm
width sections
- KE 0900
available in 16 mm
width sections



Stay variants

Frame stay RE

Standard design

Opening options:

Outside/inside: the cable carrier can be opened quickly and easily simply by rotating the stays through 90°.

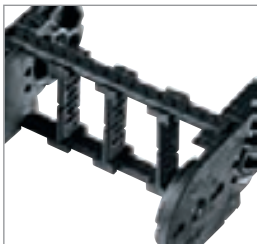

Stay arrangement

Standard: on every 2nd chain link

Stays can be fitted on every chain link, please specify when placing your order.

Types KE 0650 and 0900

Dimensions and intrinsic chain weight

Type	Stay variant	h _i	h _G	B _i min	q _k min	B _i max	q _k max	B _k	Width sections
KE 0650	RE	42	57.5	68	1.75	260	2.71	Bi + 28	8
KE 0900	RE	58	78.5	81	2.95	561	5.95	Bi + 31	16

Dimensions in mm/Weights in kg/m

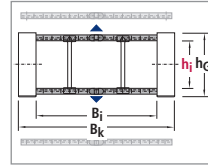

Inside heights

42
-
58

Inside widths

68
-
561

Bend radius and pitch

Type	Bend radii KR mm					
KE 0650	75	115	145	175	220	300
KE 0900	130	150	190	245	300	385

Pitch:

KE 0650: t = 65 mm

KE 0900: t = 90 mm

Load diagram

for unsupported length L_f depending on the additional load

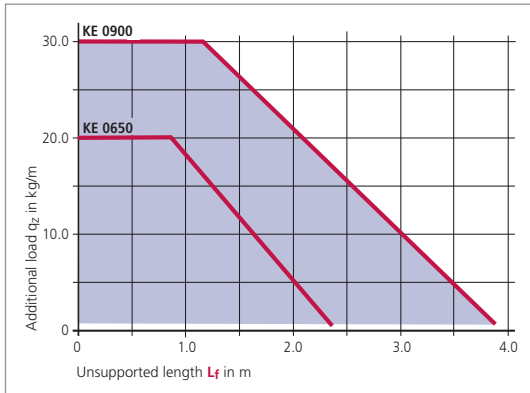

Unsupported length L_f

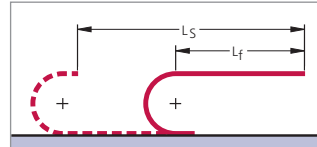

In the case of longer travel lengths, sag of the cable carriers is technically permissible depending on the application.

In a gliding arrangement, even longer travel lengths are possible (see page 295).

We are at your service to advise on these applications.

Font: +49 2762 4003-0

Example of ordering

Cable carrier

KE 0900	209	RE	190	2250
Type	Inside width B _i in mm	Stay variant	Bend radius KR in mm	Chain length L _k in mm (without connection)

Divider system

TS 0	4
Divider system	Number of dividers n _T

Connection

FU/MU
Connection Fixed point/Driver

Ordering divider systems:

Please state the designation of the divider system (TS 0, TS 1 ...) and the number of dividers. Possibly attach a sketch with the dimensions.

Types KE 0650 and 0900

Fixing the dividers

Inside heights



Inside widths



In the standard version, dividers or the complete divider system (dividers with height subdivisions) can be moved in the cross section
(**Mounting version A**)

If the fixed mounting version is desired, please state this when placing your order.

For divider systems TS 0 and TS 1 the dividers or complete divider systems (dividers with height subdivisions) can be fixed by turning the stays.
(**Mounting version B**).

Mounting version A (Standard)

Movable divider:

The arresting cam of the divider can move in the groove of the stay.

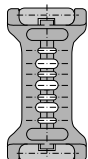

With a movable assembly of the dividers (mounting version A), the holes in the stay do not have any function and hence the dimension a_x -section has is meaningless.

Mounting version B

Fixed divider:

The arresting cam of the divider is fixed in the hole of the stay.

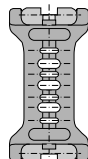

Please note that the dividers can only be fixed in positions at which there is a hole in the stay. The dimension a_x -section specifies the hole intervals in the stay.

Hole intervals = fixing positions of the dividers
(a_x -sections)

kabelschlepp.de

Fon: +49 2762 4003-0

Divider system TS 0

Type	Stay variant	h_i mm	Mounting version A			Mounting version B			
			S_T mm	a_T min mm	a_x min mm	S_T mm	a_T min mm	a_x min mm	a_x section mm
KE 0650	RE	42	4.2	6.5	13.0	4.2	22.0	16	8
KE 0900	RE	58	6.0	7.5	14.5	6.0	8.5	16	16

In the standard version, the divider systems are mounted on every second chain link.

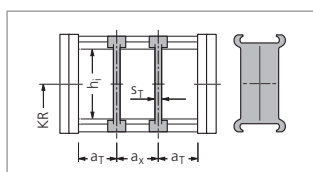

Divider system TS 1 with continuous height subdivision made of aluminium

Type	Stay variant	h_i mm	Mounting version A			Mounting version B				S_H mm	h_1 mm
			S_T mm	a_T min mm	a_x min mm	S_T mm	a_T min mm	a_x min mm	a_x section mm		
KE 0650	RE	42	4.2	6.5	13.0	4.2	22.0	16	8	4	22
KE 0900	RE	58	6.0	7.5	14.5	6.0	24.5	16	16	4	22

In the standard version, the divider systems are mounted on every second chain link.

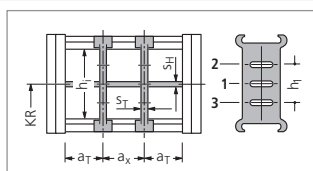

Use our free project planning service.

Types KE 0650 and 0900

Divider system TS 3 with section subdivision, partitions made of plastic

Type	Stay variant	h _i mm	S _T mm	a _T min mm	a _x min mm	S _H mm	h ₁ mm	h ₂ mm	h ₃ mm
KE 0650	RE	42	8	4	16*	4	14	28	—
KE 0900	RE	58	8	4	16*	4	14	28	42

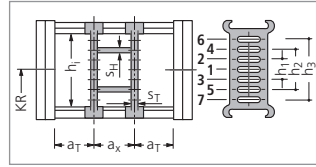

* When using plastic partitions

The dividers are fixed by the partitions, the complete divider system is movable.

In the standard version, the divider systems are mounted on every second chain link.

Inside heights



Inside widths



Dimensions of the plastic partitions for TS 3

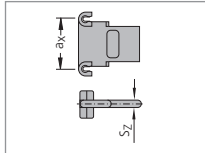

S _z	a _x (center-to-center distance, dividers)									
4	16	18	23	28	32	33	38	43	48	58
	64	68	78	80	88	96	112	128	144	160
	176	192	208	—	—	—	—	—	—	—

Dimensions in mm

Aluminium partitions in 1 mm width sections are also available.

When using partitions with $a_x > 112$ mm there should be an additional central support with a **twin divider**.

Thickness of the twin dividers: KE 0650 S_T = 3 mm, KE 0900 S_T = 4 mm

Twin dividers are designed for subsequent fitting in the partition system.

kabelschlepp.de

Glide discs and injection molded glide runners

Glide discs

If the cable carrier is arranged rotated "through 90°" (gliding on the outer side of the chain band), the glide discs attached to the side optimize the friction and wear conditions.



Determining the chain width with glide discs on both chain bands:

$$\text{KE 0650: } B_{EF'} = B_i + 36 \text{ mm}$$

$$\text{KE 0900: } B_{EF'} = B_i + 45 \text{ mm}$$

Injection molded glide runners

guarantee the long service life of the cable carrier in the case of long travel lengths and large additional loads.



Font: +49 2762 4003-0

Minimized hinge wear owing to the "life extending 2 disc principle"

In the K Series, the push and pull forces are transmitted via the optimum link design for this purpose.

As a result link wear is reduced to a minimum and the life of the cable carrier is considerably lengthened.

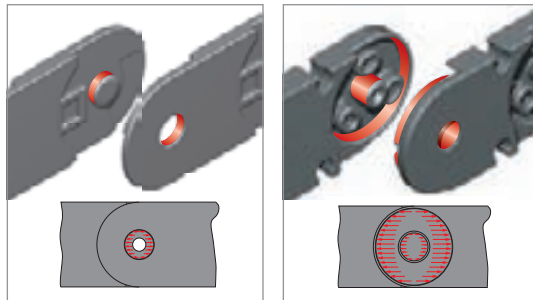

■ Force transmission with a pin-hole joint

■ Force transmission with the "life extending 2 disc principle"

OnlineEngineer.de
KABELSCHLEPP
Cable Carrier Configurator

Types KE 0650 and 0900

UMB (Universal Mounting Brackets) made of plastic – Type KE 0650

Inside heights

42
58

Inside widths

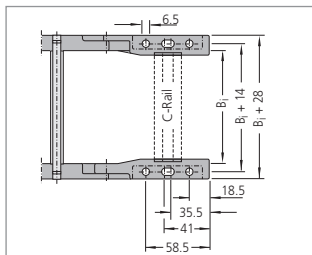
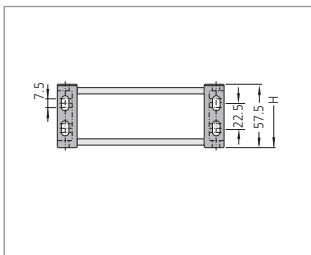
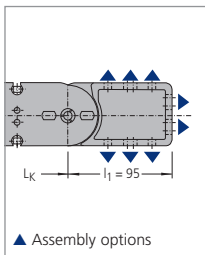
68
561

The dimensions of the fixed point and driver connections are identical.

End connectors made of steel plate available on request.

Optional C-rails and strain relief elements for cables can be found on the following pages.

When ordering please specify the connection type FU/MU (see ordering key on page 337).

kabelschlepp.de



Fon: +49 2762 4003-0

UMB (Universal Mounting Brackets) made of plastic – Type KE 0900

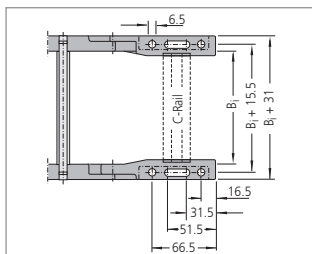
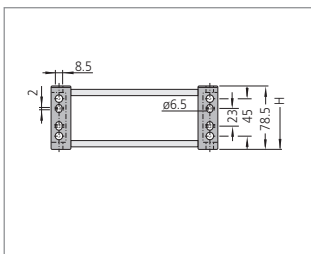
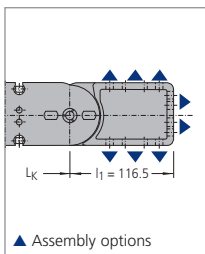

The dimensions of the fixed point and driver connections are identical.

End connectors made of steel plate available on request.

Optional C-rails and strain relief elements for cables can be found on the following pages.

When ordering please specify the connection type FU/MU (see ordering key on page 337).

Use our free project planning service.

Guide channels
➤ from page 295



Strain relief devices
➤ from page 302



Cables for cable carrier systems
➤ from page 344



Types KE 0650 and 0900

Strain relief devices

C-rails for LineFix bracket clamps, SZL strain reliefs and clamps

The optional C-rails are fixed by means of the universal mounting brackets and do not have to be screwed separately.

Please state in your order whether C-rails are needed.



■ Universal mounting bracket with C-rail

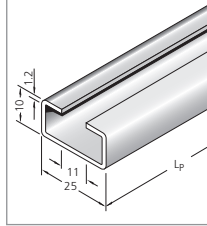

■ **KE 0650:**
Integratable C-rail
25 x 10 mm,
slit width 11 mm,
material steel,
Item-No. 3931

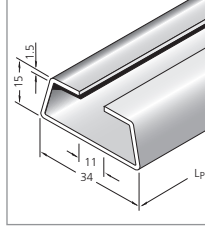

■ **KE 0900:**
Integratable C-rail
34 x 15 mm,
slit width 11 mm,
material steel,
Item-No. 3935

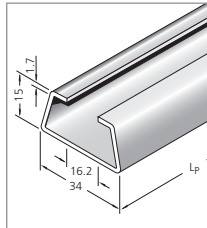

■ **KE 0900:**
Integratable C-rail
34 x 15 mm,
slit width 16 – 17 mm,
material aluminium,
Item-No. 3926,
material steel,
Item-No. 3932

Our LineFix strain reliefs are optimally suited for the C-rails. (LineFix bracket clamps and other strain relief devices – see Accessories chapter, from page 302 onwards).



■ C-rail with LineFix strain relief

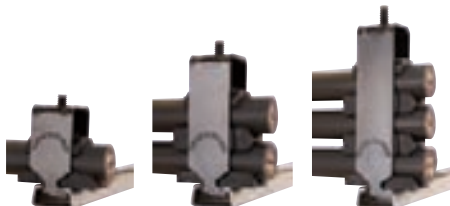

Inside heights



Inside widths



kabelschlepp.de

Font: +49 2762 4003-0

OnlineEngineer.de
KABELSCHLEPP
Cable Center Configurator



MASTER Series
The power to innovate



MASTER Series

Quiet and weight-optimized cable carriers*

- Low intrinsic weight
- Favorable ratio of inner to outer dimensions
- Standard bend radii, application-specific intermediate radii upon request
- Completely enclosed types, see MASTER TUBES

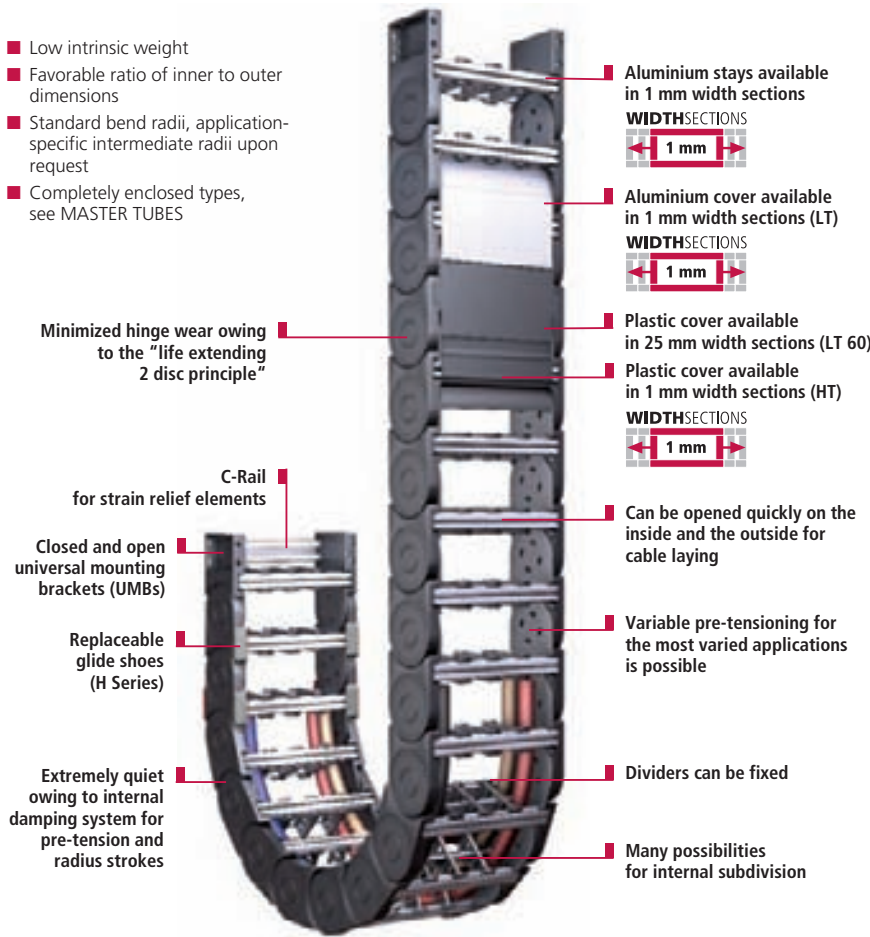

Minimized hinge wear owing to the "life extending 2 disc principle"

C-Rail for strain relief elements

Closed and open universal mounting brackets (UMBs)

Replaceable glide shoes (H Series)

Extremely quiet owing to internal damping system for pre-tension and radius strokes

Aluminium stays available in 1 mm width sections



Aluminium cover available in 1 mm width sections (LT)



Plastic cover available in 25 mm width sections (LT 60)

Plastic cover available in 1 mm width sections (HT)



Can be opened quickly on the inside and the outside for cable laying

Variable pre-tensioning for the most varied applications is possible

Dividers can be fixed

Many possibilities for internal subdivision

Inside heights



Inside widths



kabelschlepp.de

Font: +49 2762 4003-0

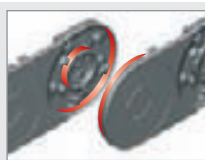

Minimized hinge wear owing to the "life extending 2 disc principle"

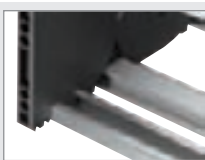

C-Rails integrated in the connector



Dividers can be fixed for installations where the carrier is rotated through 90° and applications with high transverse accelerations

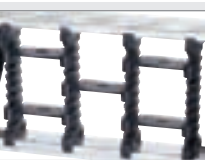

Many separation options for the cables

OnlineEngineer.de
KABELSCHLEPP
Cable Carrier Configurator

* Some features can be different for certain types for design reasons. Our specialists are happy to advise you.

Types MASTER HC/LC

with aluminium stays

- Available in 1 mm width sections (standard widths in 25 mm steps available ex-stock)

Inside heights



Inside widths



WIDTHSECTIONS



Type	h _i	B _i	Maximum travel length in m	Dynamics of unsupported arrangement		Page
				Travel speed v _{max} in m/s	Travel acceleration a _{max} in m/s ²	
HC 33	33	50 – 400	60	10	50	151
HC 46	46	50 – 400	80	8	40	151
LC 60	60	75 – 600	7*	6	30	151
LC 80	80	100 – 800	8*	5	25	151

* only unsupported

Dimensions in mm

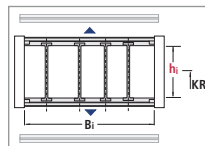

kabelschlepp.de

Fon: +49 2762 4003-0

Use our free project planning service.

Stay variants

Frame stay RSH/RSL

Frame stay made of aluminium

Opening options:

Outside/inside: the cable carrier can be opened quickly and easily simply by rotating the stays.



Stay arrangement

Stays mounted on every chain link.



- Put the tool in place, turn it through 15° and the chain is open.

TUBE SERIES – covered cable carriers

Types HT/LT with plastic or aluminium cover system

- HT 33/46 with plastic cover system
- LT 60 with plastic or aluminium cover system
- LT 80 with aluminium cover system



Types MASTER HC 33/46, LC 60/80

Dimensions and intrinsic chain weight

Type	Stay variant	h _i	h _G	B _i min*	q _k min	B _i max*	q _k max	B _k
HC 33	RSH	33	51	50	1.37	400	3.99	B _i + 22
HC 46	RSH	46	64	50	1.83	400	4.01	B _i + 26
LC 60	RSL	60	88	75	2.78	600	7.10	B _i + 28
LC 80	RSL	80	110	100	3.89	800	10.01	B _i + 32

* Standard widths in 25 mm steps

Dimensions in mm/Weights in kg/m

WIDTH SECTIONS

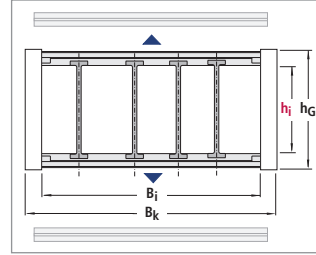

Inside heights



Inside widths



Bend radius and pitch

Type	Bend radii KR mm										
HC 33	60	75	100	125	150	175	200	220	250	300	-
HC 46	75	100	115	125	150	170	200	215	250	300	350
LC 60	135	150	200	250	300	350	400	500	-	-	-
LC 80	-	150	200	250	300	350	400	500	-	-	-

Pitch:

HC 33: t = 56 mm

HC 46: t = 67 mm

LC 60: t = 91 mm

LC 80: t = 111 mm

The listed values are standard bend radii.

For special applications it is also possible, to set any desired intermediate radii at the production stage.

Please do get in touch with us, we would be happy to advise you.

Load diagram

for unsupported length L_f depending on the additional load

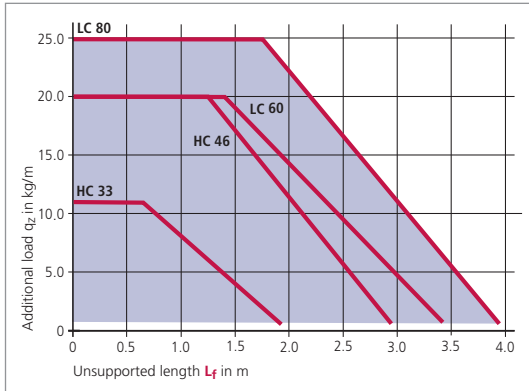

Unsupported length L_f

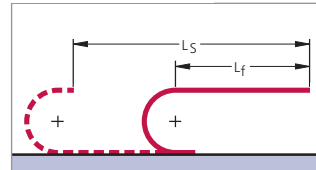

In the case of longer travel lengths, sag of the cable carriers is technically permissible depending on the application.

In a gliding arrangement, even longer travel lengths are possible (see page 295).

We are at your service to advise on these applications.

Font:

+49 2762 4003-0

Example of ordering

Cable carrier

HC 46	200	RSH	170	2010
Type	Inside width B _i in mm	Stay variant	Bend radius KR in mm	Chain length L _k in mm (without connection)

Divider system

TS 0	4
Divider system	Number of dividers n _T

Connection

FU/MU
Connection Fixed point/Driver

Ordering divider systems:

Please state the designation of the divider system (TS 0, TS 1 ...) and the number of dividers. Possibly attach a sketch with the dimensions.

Types MASTER HC 33/46, LC 60/80

Divider system TS 0

Inside heights



Inside widths



Type	h_i mm	S_T mm	a_T min mm	a_x min mm
HC 33	33	3	7	13
HC 46	46	3	7	13
LC 60	60	4	9	16
LC 80	80	4	9	16

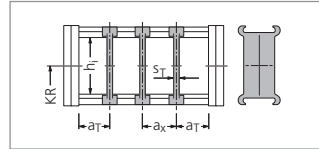

The dividers can be moved in the cross section. Dimensions in mm
In the standard version, the divider systems are mounted on every second chain link.



kabelschlepp.de

Divider system TS 1 with continuous height subdivision made of aluminium

Type	h_i mm	S_T mm	a_T min mm	a_x min mm	S_H mm	h_1 mm	h_2 mm	h_3 mm	h_4 mm
HC 33	33	3	7	13	4	18	–	–	–
HC 46	46	3	7	13	4	20	–	–	–
LC 60	60	4	9	16	4	15	30	45	–
LC 80	80	4	9	16	4	15	30	45	60

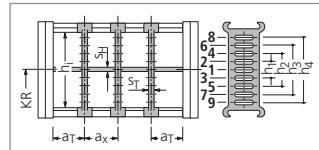

The dividers can be moved in the cross section. Dimensions in mm
In the standard version, the divider systems are mounted on every second chain link.

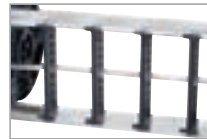

Divider system TS 3 with section subdivision, partitions made of plastic

Type	h_i mm	S_T mm	a_T min mm	a_x min mm	S_H mm	h_1 mm	h_2 mm	h_3 mm	h_4 mm
HC 33	33	8	6	16*	4	14	–	–	–
HC 46	46	8	6	16*	4	14	28	–	–
LC 60	60	8	6	16*	4	14	28	–	–
LC 80	80	8	6	16*	4	14	28	42	56

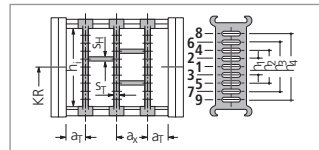

* When using plastic partitions Dimensions in mm
The dividers are fixed by the partitions, the complete divider system is movable.
In the standard version, the divider systems are mounted on every second chain link.



Dimensions of the plastic partitions for TS 3

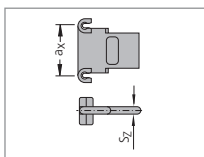

S_z	a_x (center-to-center dividers)									
	4	16	18	23	28	32	33	38	43	48
	64	68	78	80	88	96	112	128	144	160
	176	192	208	–	–	–	–	–	–	–

Dimensions in mm

When using partitions with $a_x > 112$ mm there should be an additional central support with a **twin divider**.
Twin dividers are designed for subsequent fitting in the partition system.

Use our free project planning service.

Types MASTER HC 33/46, LC 60/80

Fixing the dividers

In the standard version, dividers or the complete divider system (dividers with height subdivisions) can be moved in the cross section.

Fixing profiles can be used to fix the dividers or complete divider systems.

Fixing in HC 33/46 in 2 mm steps, in LC 60/80 in 3 mm steps.



■ Fixing on both sides ensures that the dividers have a secure hold.



■ Fixing of dividers with fixing profiles



■ The fixing profiles are simply pushed into the stays.

If the fixed mounting version is desired, please state this when placing your order.

Inside heights



Inside widths



Glide shoes – the economical solution for gliding applications (HC 33/46)

Replaceable glide shoes made of plastic

To extend the life of cable carriers in gliding operations KABELSCHLEPP supplies detachable, exchangeable glide shoes.

Replaceable glide shoes are a very economical solution. When wear occurs only the glide shoes are replaced, and not the complete cable carrier.

Glide shoes for the H Series are made of a highly wear-resistant special material.



Chain height with glide shoes:

$$\text{HC 33: } h_G' = h_G + 3.2 = 54.2$$

$$\text{HC 46: } h_G' = h_G + 3.2 = 67.2$$

Dimensions in mm

Minimum bend radii when using glide shoes:

$$\text{HC 33: } KR_{\min} = 100 \text{ mm}$$

$$\text{HC 46: } KR_{\min} = 100 \text{ mm}$$



By means of a positive snap connection, the glide shoes sit firmly on the chain link.

Font:

+49 2762 4003-0

Minimized hinge wear owing to the "life extending 2 disc principle"

In the MASTER Series, the push and pull forces are transmitted via the optimum link design for this purpose.

As a result link wear is reduced to a minimum and the life of the cable carrier is considerably lengthened.

The internal stopper and pre-tensioning dampers have a noise-muffling effect. This makes the chain particularly quiet.

Should your application require it, the pre-tensioning (in deviation from the standard pre-tensioning) can be adjusted at the time of production. We can produce a cable carrier with a pre-tension which is exactly suited to the load values of your application.

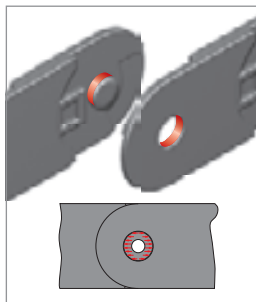

■ Force transmission with a pin-hole joint

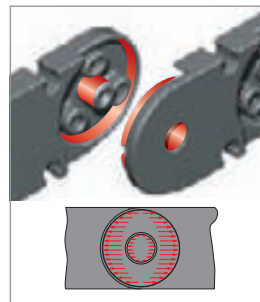

■ Force transmission with the "life extending 2 disc principle"

Types MASTER HC 33/46, LC 60/80

UMB (Universal Mounting Brackets) made of plastic

Various universal mounting brackets made of plastic provide a suitable connection for any assembly situation. Each type can be screwed from above, below or as a flange.

Inside heights



Inside widths

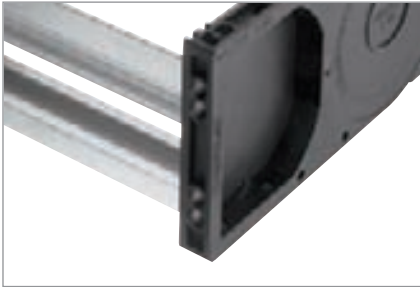

■ Standard connector



■ Long, closed connector for many of the hole patterns commercially available with large hole intervals (only LC)

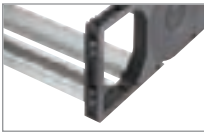

■ Short, open connector, easy assembly owing to optimal accessibility of the holes in restricted installation conditions (only LC)

kabelschlepp.de

Connection dimensions Type HC 33

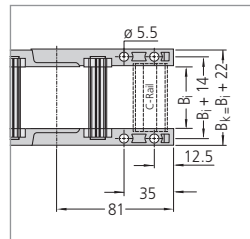
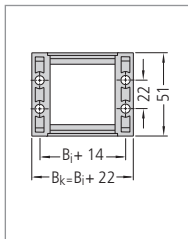
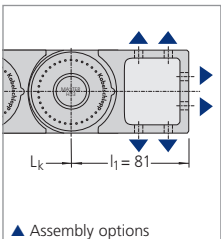

The dimensions of the fixed point and driver connections are identical!

Optional C-rails and strain relief elements for cables can be found on the following pages.

When ordering please specify the connection type FU/MU (see ordering key on page 337).

Fon: +49 2762 4003-0

Connection dimensions Type HC 46

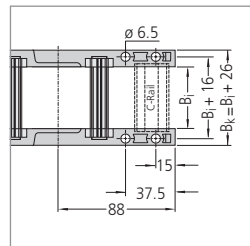
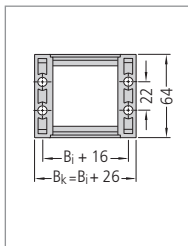
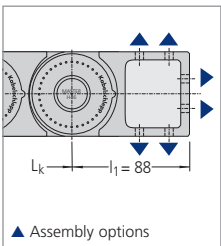

The dimensions of the fixed point and driver connections are identical!

Optional C-rails and strain relief elements for cables can be found on the following pages.

When ordering please specify the connection type FU/MU (see ordering key on page 337).

Use our free project planning service.

Types MASTER HC 33/46, LC 60/80

Connection dimensions Type LC 60

Standard connector and short, open connector

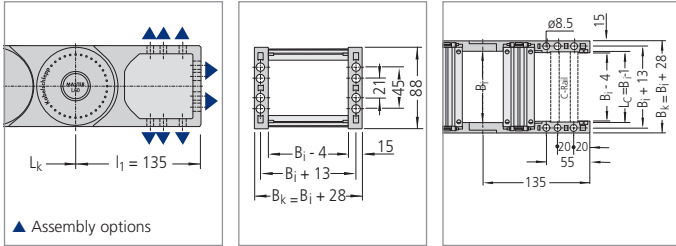

Inside heights

33
-
80

Inside widths

50
-
800

The dimensions of the fixed point and driver connections are identical!

Optional C-rails and strain relief elements for cables can be found on the following pages.

When ordering please specify the connection type FU/MU (see ordering key on page 337).

Connection dimensions Type LC 80

Standard connector and short, open connector

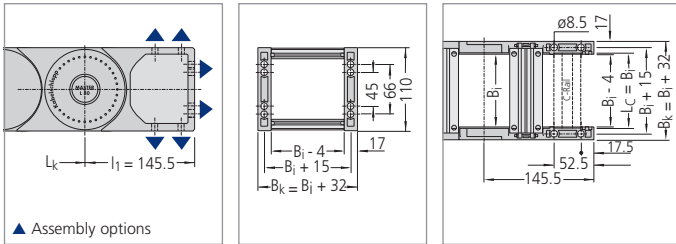

The dimensions of the fixed point and driver connections are identical!

Optional C-rails and strain relief elements for cables can be found on the following pages.

When ordering please specify the connection type FU/MU (see ordering key on page 337).

Long, closed connector

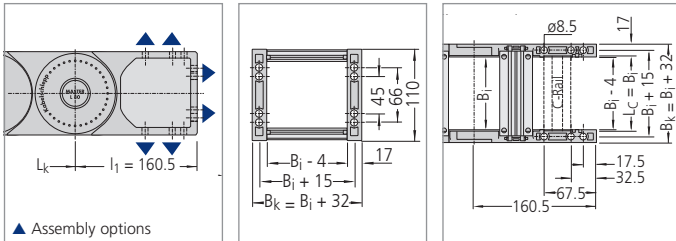

The dimensions of the fixed point and driver connections are identical!

Optional C-rails and strain relief elements for cables can be found on the following pages.

When ordering please specify the connection type FU/MU (see ordering key on page 337).

kabelschlepp.de

Font: +49 2762 4003-0

OnlineEngineer.de
With CONCEPT
Cable Center Configurator

Types MASTER HC 33/46, LC 60/80

Strain relief devices

Strain relief combs made of plastic on both sides for standard carrier widths (MASTER HC)

The cables can be fixed securely and simply using the **optional strain relief combs**.

The strain relief combs are installed between the UMBs, and do not need to be bolted on separately or mounted on a C-Rail.

Please state on the order whether strain relief combs are needed.

Inside heights



Inside widths

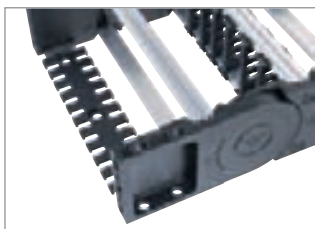

■ Universal mounting bracket with strain relief comb



■ Both-sided strain relief comb

kabelschlepp.de



■ Fixing in the UMB.

Type	B _i mm	n _z
HC 33/46	50	3
HC 33/46	70	5
HC 33/46	75	5
HC 33/46	95	7
HC 33/46	100	7
HC 33/46	115	8
HC 33/46	120	9
HC 33/46	125	9
HC 33/46	145	11
HC 33/46	150	11
HC 33/46	170	13
HC 33/46	175	13
HC 33/46	195	15
HC 33/46	200	15
HC 33/46	225*	17
HC 33/46	250*	19

n_z = Number of teeth on one side of the comb

* on request

Fon: +49 2762 4003-0

Strain relief comb made of aluminium on one side for individual carrier widths (MASTER HC)

The cables can be fixed securely and simply using the **optional strain relief combs**.

The strain relief combs are installed between the universal mounting brackets, and do not need to be bolted on separately or mounted on a C-Rail.

Please state on the order whether strain relief combs are needed.

Use our free project planning service.



■ Strain relief comb made of aluminium

Types MASTER HC 33/46, LC 60/80

Strain relief devices

C-rails for LineFix bracket clamps, SZL strain reliefs and clamps

The optional C-rails are fixed by means of the universal mounting brackets and do not have to be screwed separately.

Please state in your order whether C-rails are needed.



■ Universal mounting bracket with C-rail

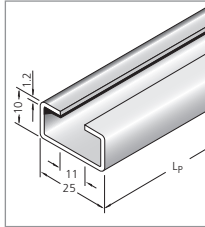

■ **MASTER HC:**
Integratable C-rail
25 x 10 mm,
slit width 11 mm,
material steel,
Item-No. 3931

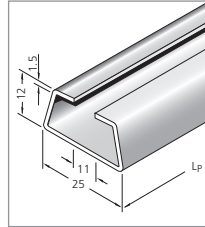

■ **MASTER LC:**
Integratable C-rail
25 x 12 mm,
slit width 11 mm,
material steel,
Item-No. 3934

Inside heights



Inside widths



Our LineFix strain reliefs are optimally suited for the C-rails. (LineFix bracket clamps and other strain relief devices – see Accessories chapter, from page 302 onwards).



■ C-rail with LineFix strain relief

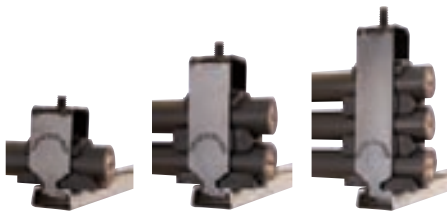

kabelschlepp.de

Font:
+49 2762 4003-0

OnlineEngineer.de
with
Cable
Carrier
Configurator

Guide channels
► from page 295

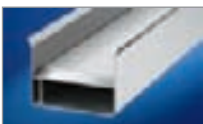

Strain relief devices
► from page 302



Cables for cable carrier systems
► from page 344



M Series

The power to innovate



M Series

Multivariable cable carrier with extensive accessories and stay variants*

■ TÜV design approved in accordance with 2PFG 1036/10.97**

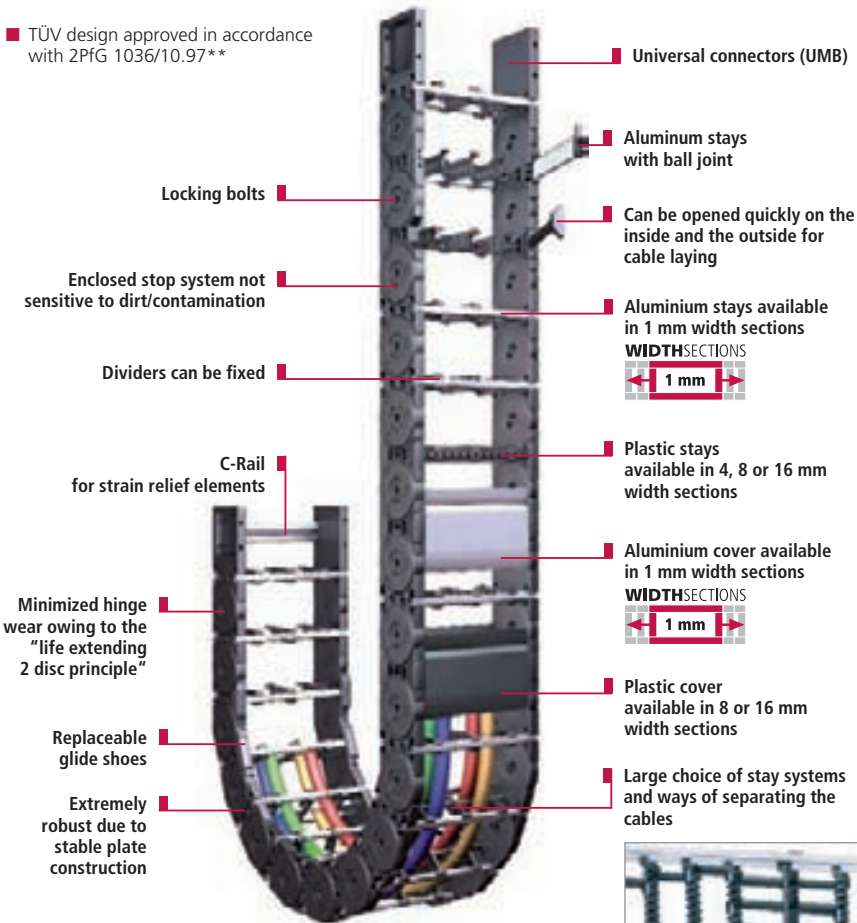

Inside heights



Inside widths



kabelschlepp.de

Fon: +49 2762 4003-0

Subject to change.



Minimized hinge wear owing to the "life extending 2 disc principle"



Solid plate construction, enclosed impact system



Easy-to-fit with locking bolts



Replaceable glide shoes for long service life for gliding applications

OnlineEngineer.de
KABELSCHLEPP
Cable Carrier Configurator

* Some features can be different for certain types for design reasons. Our specialists are happy to advise you.
** not MC 1300

Overview M Series

Type MC with detachable aluminium stays

Inside heights



Inside widths



WIDTH SECTIONS



- Available in 1 mm width sections

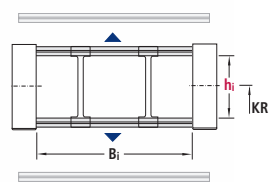
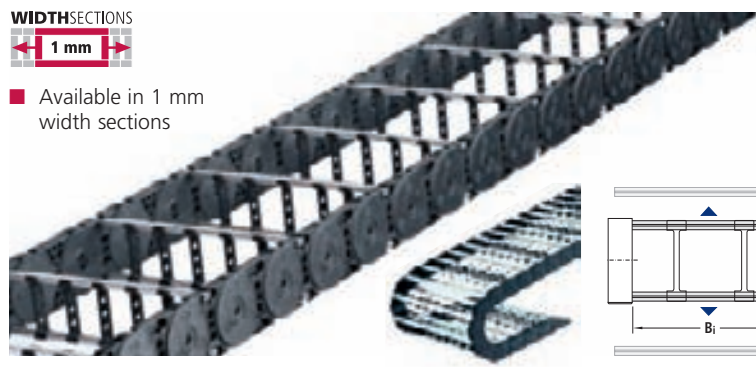

kabelschlepp.de

Type	hi	Bi	Maximum travel length in m	Dynamics of unsupported arrangement		Page
				Travel speed v _{max} in m/s	Travel acceleration a _{max} in m/s ²	
MC 0320	19	25-280	80	10	50	163
MC 0650	38	75-500	220	8	40	163
MC 0950	58	100-600	260	6	30	163
MC 1250	72	100-800	320	5	25	163
MC 1300	87	100-800	350	5	25	163

Dimensions in mm

Type ME with unscrewable plastic stays

- Available in 4, 8, 16 mm width sections

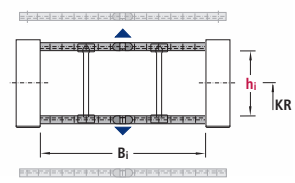
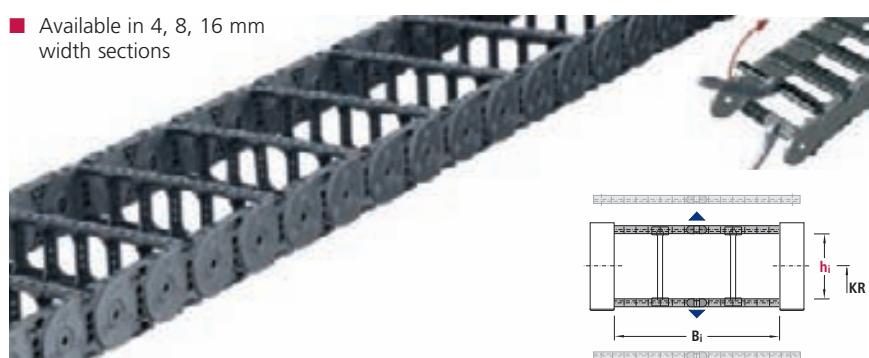

Fon: +49 2762 4003-0

Use our free project planning service.

Type	hi	Bi	Maximum travel length in m	Dynamics of unsupported arrangement		Page
				Travel speed v _{max} in m/s	Travel acceleration a _{max} in m/s ²	
ME 0320	19	25-149	80	10	50	170
ME 0650	42	50-266	220	8	40	170
ME 0950	58	45-557	260	6	30	170
ME 1250	72	71-551	320	5	25	170

Dimensions in mm

Overview M Series

Type MK with openable plastic stays

- Available in 8 or 16 mm width sections

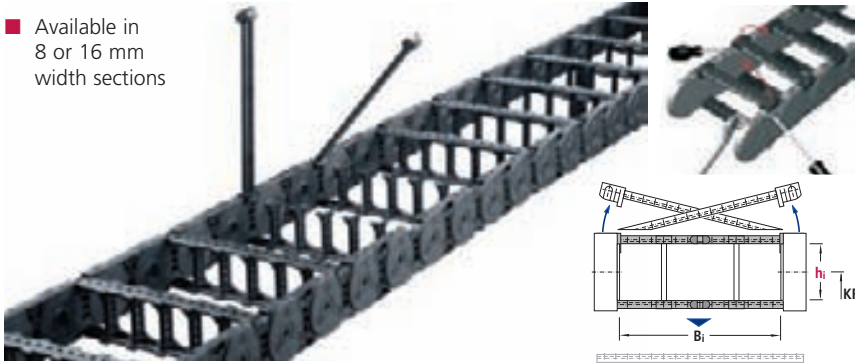

Inside heights



Inside widths



Type	h_i	B_i	Maximum travel length in m	Dynamics of unsupported arrangement		Page
				Travel speed v_{max} in m/s	Travel acceleration a_{max} in m/s ²	
MK 0475	28	24-280	120	10	50	170
MK 0650	42	50-258	220	8	40	170
MK 0950	58	45-557	260	6	30	170
MK 1250	72	71-551	320	5	25	170

Dimensions in mm

TUBE SERIES – covered cable carriers

Type MT with plastic or aluminium cover system

- Available types: MT 0475, 0650, 0950, 1250 and 1300

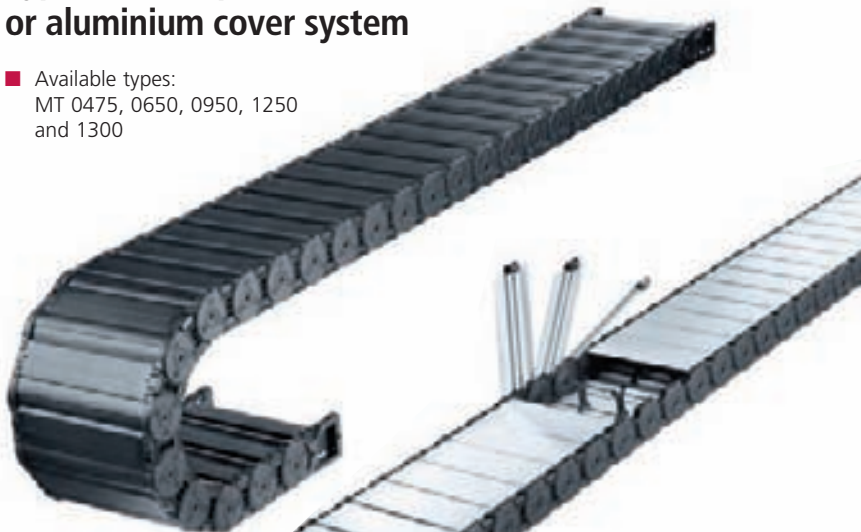

kabelschlepp.de

Font: +49 2762 4003-0

OnlineEngineer.de
With CableSlepp
 Cable Carrier Configurator

Type MC

with aluminium stays

- Available in 1 mm width sections

WIDTH SECTIONS

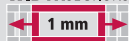

Inside heights



Inside widths



kabelschlepp.de

Font:
+49 2762 4003-0

Use our free
project planning service.

162

Stay variants

Frame stay RS

Standard design –
MC 0650 and 0950

For lightweight to medium loads.

Opening options:

Outside/Inside: the cable carrier can be opened quickly and easily simply by rotating the stays through 90°.

Frame stay RV

Reinforced design –
MC 0950 and 1250

For medium to heavy loads and for large chain widths.

Opening options:

Outside/Inside: the cable carrier can be opened quickly and easily simply by rotating the stays through 90°.

Frame stay RM

Solid design –
MC 0950, 1250 and 1300

Bolted, maximum stability, maximum chain widths possible.

Frame stay RMF

Solid design
with optional fixing strip –
Standard for MC 1300

Opening options:

Outside/Inside: Stays easily screwed on. Stays can be removed quickly on both sides for laying cables.

Frame stay RMS

Solid design
with ball joint – MC 1300

Opening options:

Outside/Inside: Stays with ball joint can be opened quickly and easily on both sides.

Stay arrangement

MC 0320 – Stays mounted on every chain link.

MC 0650, 0950, 1250 and 1300 –

Standard: on every 2nd chain link

Stays can be fitted on every chain link, please specify when placing your order.

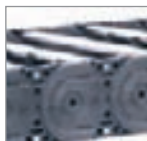

Additional stay variants:



Stay variant LG made of aluminium: Optimum cable guidance in the neutral bending line



Stay variant RMA: For very large cable diameters, such as e.g. with air hoses



Stay variant RMR: Gentle cable laying by means of rollers. Ideal when using hydraulic hoses with "soft" sheaths

Opening options MC 0320

Opening option 02: Detachable stays on the outside (standard)

Opening option 01: Detachable stays on the inside.

If you require opening variant 01, please state this when placing your order.

Types MC 0320, 0650, 0950, 1250, 1300

Dimensions and intrinsic chain weight

Type	Stay variant	h _i	h _G	B _i min	q _k min	B _i max	q _k max	B _k
MC 0320	RS	19	27.5	25	0.42	280	1.65	B _i + 11
MC 0650	RS	38	57	75	2.00	400	3.80	B _i + 34
MC 0950	RS	58	80	100	3.20	400	4.70	B _i + 39
MC 0950	RV	58	80	100	3.50	500	5.90	B _i + 39
MC 0950	RM	54	80	100	3.40	600	6.60	B _i + 39
MC 1250	RV	72	96	100	4.40	600	6.30	B _i + 45
MC 1250	RM	69	96	100	4.50	800	8.40	B _i + 45
MC 1300	RMF	87	120	100	6.10	800	9.20	B _i + 50
MC 1300	RM	87	120	100	6.10	800	9.20	B _i + 50
MC 1300	RMS	87	120	100	6.10	800	9.20	B _i + 50

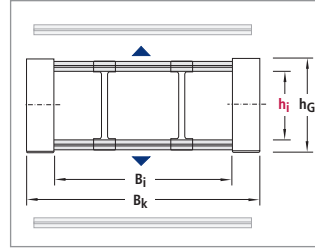

Dimensions in mm/Weights in kg/m

Inside heights



Inside widths



Dimensions and intrinsic chain weight

Type	Bend radii KR mm								
MC 0320	37	47	77	100	200	-	-	-	-
MC 0650	75	95	115	145	175	220	260	275	300
MC 0950	140	170	200	260	290	320	380	-	-
MC 1250	180	220	260	300	340	380	500	-	-
MC 1300	150	195	240	280	320	360	400	500	-

Pitch:

- MC 0320: t = 32 mm
- MC 0650: t = 65 mm
- MC 0950: t = 95 mm
- MC 1250: t = 125 mm
- MC 1300: t = 130 mm

Load diagram

for unsupported length L_f depending on the additional load

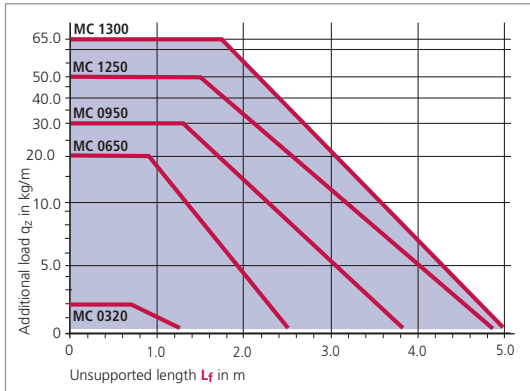

Unsupported length L_f

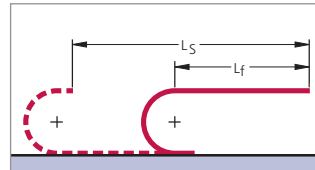

In the case of longer travel lengths, sag of the cable carriers is technically permissible depending on the application.

In a gliding arrangement, even longer travel lengths are possible (see page 295).

We are at your service to advise on these applications.

Font: +49 2762 4003-0

Example of ordering

Cable carrier				Divider system		Connection	
MC 1300	600	RMF	360	2600	TS 0	7	FU/MU
Type	Inside width B _i in mm	Stay variant	Bend radius KR in mm	Chain length L _k in mm (without connection)	Divider system	Number of dividers n _T	Connection Fixed point/Driver

Ordering divider systems:

Please state the designation of the divider system (TS 0, TS 1 ...) and the number of dividers. Possibly attach a sketch with the dimensions.

Types MC 0320, 0650, 0950, 1250, 1300

Divider system TS 0

Inside heights



Inside widths



Type	Stay variant	h _i mm	S _T mm	a _T min mm	a _x min mm
MC 0320	RS	19	2	3	6
MC 0650	RS	38	3	4.5	13
MC 0950	RS	58	4	4.5	14
MC 0950	RV	58	4	4.5	14
MC 0950	RM	54	4	7	14
MC 1250	RV	72	6	8	16
MC 1250	RM	69	5	10	20
MC 1300	RMF/RM	87	5	7.5	15
MC 1300	RMS	87	5	15.5	15

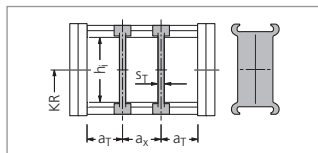

In the standard version, the divider systems are mounted on every second chain link.

The dividers can be moved in the cross section. Dimensions in mm
Fixed installation version for MC 1300 – see page 165

Divider system TS 1 with continuous height subdivision made of aluminium

Type	Stay variant	h _i mm	S _T mm	a _T min mm	a _x min mm	S _H mm	h ₁ mm	h ₂ mm	h ₃ mm
MC 0320	RS	19	2	3	6	2	10	–	–
MC 0650	RS	38	3	4.5	13	4	15	–	–
MC 0950	RS	58	4	4.5	14	4	30	–	–
MC 0950	RV	58	4	4.5	14	4	15	30	–
MC 1250	RV	72	6	8	16	4	15	30	45
MC 1300	RMF/RM	87	5	7.5	15	4	24	48	–
MC 1300	RMS	87	5	15.5	15	4	24	48	–

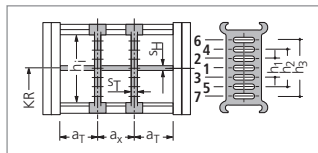

In the standard version, the divider systems are mounted on every second chain link.

The dividers can be moved in the cross section. Dimensions in mm
Fixed installation version for MC 1300 – see page 165

Divider system TS 3

MC 0650, 0950, 1250 and 1300 with section subdivision, partitions made of plastic.

For these types, divider system TS 2 with grid subdivision made of aluminium (1 mm grid) is also available.

Type	Stay variant	h _i mm	S _T mm	a _T min mm	a _x min mm	S _H mm	h ₁ mm	h ₂ mm	h ₃ mm	h ₄ mm
MC 0650	RS	38	8	4	16*	4	14	28	–	–
MC 0950	RV	58	8	4	16*	4	14	28	42	–
MC 1250	RV	72	8	4	16*	4	14	28	42	56
MC 1300	RMF/RM	87	8	7.5	16*	4	14	28	42	56
MC 1300	RMS	87	8	15.5	16*	4	14	28	42	56

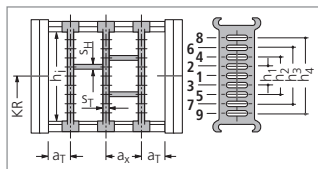

In the standard version, the divider systems are mounted on every second chain link.

The dividers are fixed by the partitions, the complete divider system is movable. Dimensions in mm
Fixed installation version for MC 1300 – see page 165
* When using plastic partitions

Dimensions of the plastic partitions for TS 3

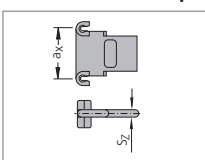

S _z	a _x (Mittensabstand Trennstufe)									
	4	16	18	23	28	32	33	38	43	48
	64	68	78	80	88	96	112	128	144	160
	176	192	208	–	–	–	–	–	–	–

Dimensions in mm

When using partitions with a_x > 112 mm there should be an additional central support with a twin divider.
Thickness of the twin dividers: MC 0650 S_T = 3 mm, MC 0950, 1250, 1300 S_T = 4 mm
Twin dividers are designed for subsequent fitting in the partition system.

kabelschlepp.de

Fon: +49 2762 4003-0

Use our free project planning service.

Types MC 0320, 0650, 0950, 1250, 1300

Fixing the dividers in 5 mm steps – Type MC 1300

In the standard version, dividers or the complete divider system (dividers with height separation) can be moved in the cross section.

Fixing profiles can be used to fix the dividers or complete divider systems. Also best suited for applications where the carrier is rotated through 90° with extreme transverse accelerations (fixable dividers for stay variant RMF/RMS).

If the fixed installation version is required, please state this when placing your order.

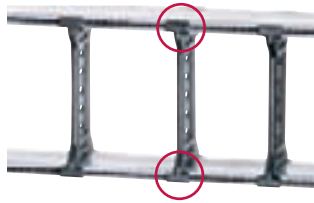

■ Secure seating of the dividers due to fixing on both sides.



■ The fixing profiles are simply pushed into the stays (RMF).

Inside heights



Inside widths



Gliding elements – the economical solution for gliding applications

Replaceable glide shoes made of plastic*

To extend the life of cable carriers in gliding operations KABELSCHLEPP supplies detachable, exchangeable glide shoes.

Replaceable glide shoes are a very economical solution. When wear occurs only the glide shoes are replaced, and not the complete cable carrier. For travel speeds > 2.5 m/s and large additional loads, a highly wear-resistant special material is used.

For types MC 0950 and 1250 **OFFROAD glide shoes** with 80 % greater wear volumes are also available. We recommend their use in extreme environmental conditions (with particularly abrasive materials such as e. g. sand, dust, corundum).



* not for MC 0320

Chain height with glide shoes:

MC 0650:	$h_G' = h_G + 3.2 = 60.2$
MC 0950:	$h_G' = h_G + 3.5 = 83.5$
MC 1250:	$h_G' = h_G + 3.5 = 99.5$
MC 1300:	$h_G' = h_G + 7.0 = 127.0$

Dimensions in mm

Minimum bend radii when using glide shoes:

MC 0650:	$KR_{min} = 95$ mm
MC 0950:	$KR_{min} = 140$ mm
MC 1250:	$KR_{min} = 180$ mm
MC 1300:	$KR_{min} = 195$ mm

! By means of a positive snap connection, the glide shoes sit firmly on the chain link.

kabelschlepp.de

Font: +49 2762 4003-0

Minimized hinge wear owing to the “life extending 2 disc principle”

In the M Series*, the push and pull forces are transmitted via the optimum link design for this purpose.

As a result link wear is reduced to a minimum and the life of the cable carrier is considerably lengthened.

* not for type 0320

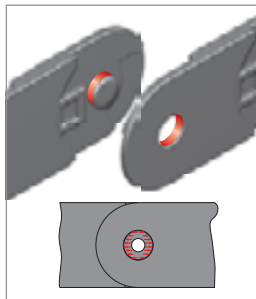

■ Force transmission with a pin-hole joint

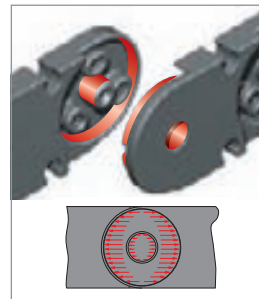

■ Force transmission with the “life extending 2 disc principle”

OnlineEngineer.de
KABELSCHLEPP
Cable Carrier Configurator

Types MC 0320, 0650, 0950, 1250, 1300

Connectors made of plastic/aluminium – Type MC 0320

Standard connectors without strain relief.
Connectors with strain relief available on request.

Inside heights
19
87

Inside widths
25
800

kabelschlepp.de

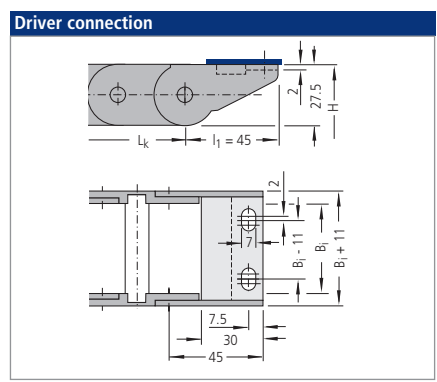
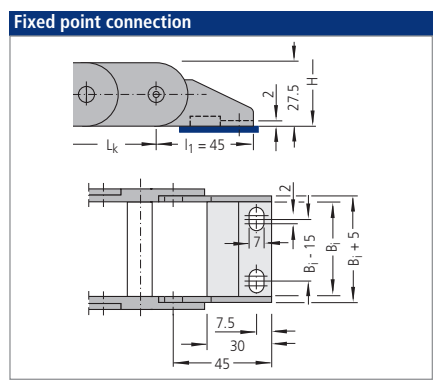

Connection variants – Type MC 0320

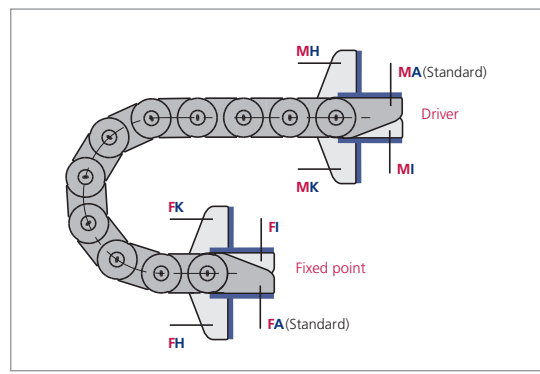

Connection point

- M** – Driver
- F** – Fixed point

Connection type

- A** – Threaded joint outside (standard)
- I** – Threaded joint inside
- H** – Threaded joint, rotated through 90° to the outside
- K** – Threaded joint, rotated through 90° to the inside

In the standard version, the connectors are mounted with the threaded joint outwards (**FA/MA**).

When ordering please specify the desired connection type (see ordering key on page 337).

The connection type can subsequently be altered simply by varying the connectors.

Fon: +49 2762 4003-0

Use our free project planning service.

Guide channels
➤ from page 295

Strain relief devices
➤ from page 302

Cables for cable carrier systems
➤ from page 344



Types MC 0320, 0650, 0950, 1250, 1300

UMB (Universal Mounting Brackets) made of aluminium – Type MC 0650

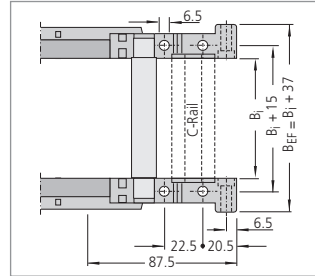
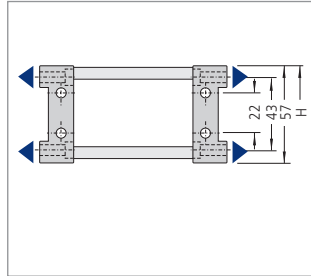
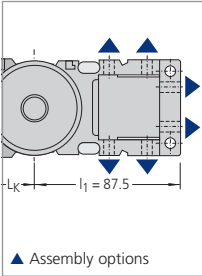

Inside heights

19
|
87

Inside widths

25
|
800

The dimensions of the fixed point and driver connections are identical.
End connectors made of steel plate available on request.

Optional C-rails and strain relief elements for cables can be found on the following pages.

When ordering please specify the connection type FU/MU (see ordering key on page 337).



kabelschlepp.de

UMB (Universal Mounting Brackets) made of aluminium – Types MC 0950 and 1250

UMB (Universal Mounting Brackets) made of plastic – Type MC 1300

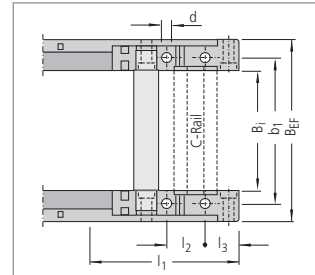
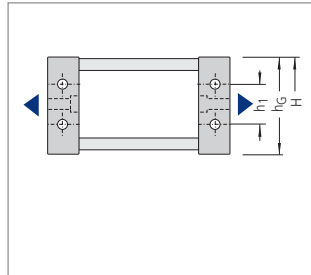
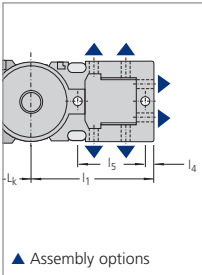

The dimensions of the fixed point and driver connections are identical.
End connectors made of steel plate available on request.

Optional C-rails and strain relief elements for cables can be found on the following pages.

When ordering please specify the connection type FU/MU (see ordering key on page 337).

Fon:

+49 2762 4003-0

OnlineEngineer.de
KABELSCHLEPP
Cable Carrier Configurator



Type	B _{EF}	b ₁	d	l ₁	l ₂	l ₃	l ₄	l ₅	h ₁	h _G
MC 0950	B _i + 44	B _i + 24.5	8.5	136	35	24.5	8.5	80	45	80
MC 1250	B _i + 51	B _i + 28	11	168	35	31	10.5	94.5	45	96
MC 1300	B _i + 50	B _i + 29	11	158	35	20	–	–	66	120

Types MC 0320, 0650, 0950, 1250, 1300

Strain relief devices

Both-sided strain relief combs made of plastic (MC 0650)

The cables can be fixed securely and simply using the **optional strain relief combs**.

The strain relief combs are installed between the UMBs, and do not need to be bolted on separately or mounted on a C-Rail.

Please state on the order whether strain relief combs are needed.

Inside heights



Inside widths

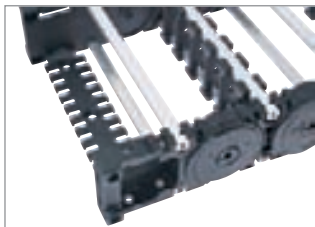

■ Universal mounting bracket with strain relief comb

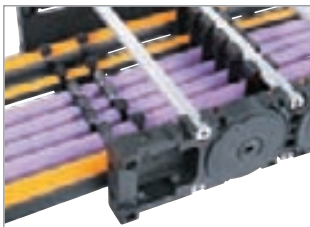

■ Both-sided strain relief comb

kabelschlepp.de



■ Fixing in the UMB.

Type	B _i mm	n _z
MC 0650	75	5
MC 0650	95	7
MC 0650	100	7
MC 0650	115	8
MC 0650	120	9
MC 0650	125	9
MC 0650	145	11
MC 0650	150	11
MC 0650	170	13
MC 0650	175	13
MC 0650	195	15
MC 0650	200	15
MC 0650	225*	17
MC 0650	250*	19

n_z = Number of teeth on one side of the comb

* on request

Fon: +49 2762 4003-0

Use our free project planning service.

Types MC 0320, 0650, 0950, 1250, 1300

Strain relief devices

C-rails for LineFix bracket clamps, SZL strain reliefs and clamps

The optional C-rails are fixed by means of the universal mounting brackets and do not have to be screwed separately.

Please state in your order whether C-rails are needed.



■ Universal mounting bracket with C-rail

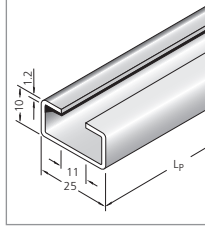

■ **MC 0650:**
Integratable C-rail
25 x 10 mm,
slit width 11 mm,
material steel,
Item-No. 3931

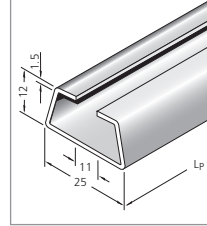

■ **MC 1300:**
Integratable C-rail
25 x 12 mm,
slit width 11 mm,
material steel,
Item-No. 3934

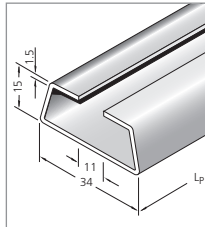

■ **MC 0950, 1250 and 1300:**
Integratable C-rail
34 x 15 mm,
slit width 11 mm,
material steel,
Item-No. 3935

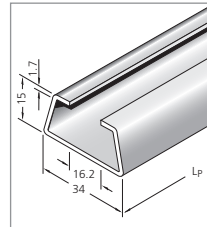

■ **MC 0950, 1250 and 1300:**
Integratable C-rail
34 x 15 mm,
slit width 16 – 17 mm,
material aluminium,
Item-No. 3926,
material steel,
Item-No. 3932

Our LineFix strain reliefs are optimally suited for the C-rails. (LineFix bracket clamps and other strain relief devices – see Accessories chapter, from page 302 onwards).



■ C-rail with LineFix strain relief

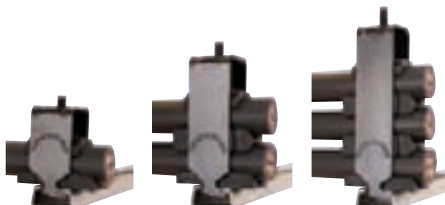

Inside heights



Inside widths



kabelschlepp.de

Font:
+49 2762 4003-0

OnlineEngineer.de
KABELSCHLEPP
Cable Center Configurator

Type ME/MK

with plastic stays

- ME 0320
available in 4 mm width sections
- MK 0475, ME/MK 0650
available in 8 mm width sections
- ME/MK 0950/1250
available in 16 mm
width sections



Inside
heights

19
—
72

Inside
widths

24
—
557

Types ME 0320, 0650, 0950 and 1250

(Stay variant RE, unscrewable stays)

Opening options

Outside/Inside: simply by turning

Stay arrangement

ME 0320

Stays mounted on every chain link.

ME 0650, 0950 and 1250

Standard: on every 2nd chain link

Stays can be fitted on every chain link,
please specify when placing your order.



Types MK 0475, 0650, 0950 and 1250

(Stay variant RD, opening stays)

Opening options

MK 0475

Opening variant 02 (Standard):

Outside: simply by levering open
(right or left)

Inside: simply by turning

Opening variant 01:

Outside: simply by levering open
(right or left) If you require opening
variant 01, please state when placing
your order.

MK 0650, 0950 and 1250

Outside: simply by levering open
(right or left)

Inside: simply by turning



Stay arrangement

MK 0475

Stays mounted on every chain link.

MK 0650, 0950 and 1250

Standard: on every 2nd chain link

Stays can be fitted on every chain link,
please specify when placing your order.

Types ME 0320, MK 0475, ME/MK 0650, 0950, 1250

Dimensions and intrinsic chain weight

Type	Stay variant	h _i	h _G	B _i min	q _k min	B _i max	q _k max	B _k	Width sections
ME 0320	RE	19	27.5	25	0.46	149	0.85	B _i + 11	4
MK 0475	RD	28	39	24	0.79	280	3.03	B _i + 17	8
ME 0650	RE	42	57	50	2.00	266	2.84	B _i + 34	8
MK 0650	RD	42	57	50	2.00	258	2.81	B _i + 34	8
ME/MK 0950	RE/RD	58	80	45	3.00	557	6.20	B _i + 39	16
ME/MK 1250	RE/RD	72	96	71	4.30	551	5.80	B _i + 45	16

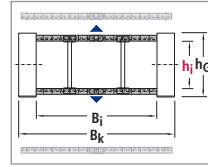

Dimensions in mm/Weights in kg/m

Inside heights



Inside widths



Bend radius and pitch

Type	Bend radii KR mm									
ME 0320	37	47	77	100	200	-	-	-	-	-
MK 0475	55	75	100	130	160	200	250	300	-	-
ME/MK 0650	75	95	115	145	175	220	260	275	300	350
ME/MK 0950	140	170	200	260	290	320	380	-	-	-
ME/MK 1250	180	220	260	300	340	380	500	-	-	-

Pitch:

- ME 0320: t = 32 mm
- MK 0475: t = 47.5 mm
- ME/MK 0650: t = 65 mm
- ME/MK 0950: t = 95 mm
- ME/MK 1250: t = 125 mm

Load diagram

for unsupported length L_f depending on the additional load

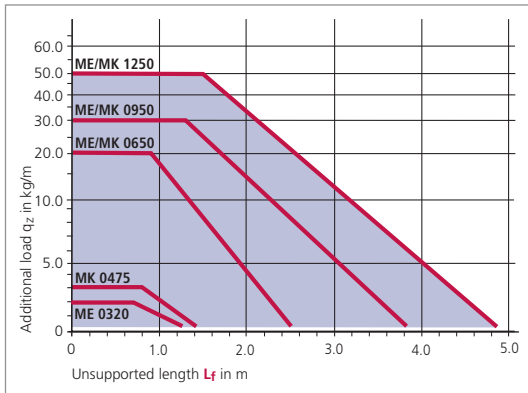

Unsupported length L_f

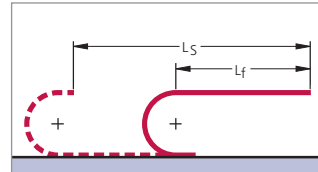

In the case of longer travel lengths, sag of the cable carriers is technically permissible depending on the application.

In a gliding arrangement, even longer travel lengths are possible (see page 295).

We are at your service to advise on these applications.

Font: +49 2762 4003-0

Example of ordering

Cable carrier				Divider system		Connection	
ME 1250	407	RE	340	2875	TS 0	5	FU/MU
Type	Inside width B _i in mm	Stay variant	Bend radius KR in mm	Chain length L _k in mm (without connection)	Divider system	Number of dividers n _T	Connection Fixed point/Driver

Ordering divider systems:

Please state the designation of the divider system (TS 0, TS 1 ...) and the number of dividers. Possibly attach a sketch with the dimensions.

Types ME 0320, MK 0475, ME/MK 0650, 0950, 1250

Fixing the dividers

In the standard version, dividers or the complete divider system (dividers with heightseparation) can be moved in the cross section.
(Mounting version A)

However, it is often also possible to fix dividers or complete divider systems (dividers with height separation) by turning the stays.
(Mounting version B).

If the fixed mounting version is desired, please state this when placing your order.

Inside heights



Inside widths



kabelschlepp.de

Font:
+49 2762 4003-0

Use our free
project planning service.

Types ME 0320

Mounting version A (standard)

Movable divider:

Divider without arresting cams

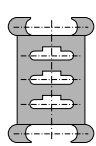

Caution: With type ME 0320, the stay does not have a groove. Different dividers are required for mounting versions A and B:

Version A: Dividers **without** arresting cams

Version B: Dividers **with** arresting cams

Mounting version B

Fixed divider:

Divider with arresting cams

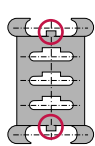

Thus, with type ME 0320, the mounting version A **cannot** be changed into mounting version B simply by turning the stay.

Types MK 0475, ME/MK 0650, 0950 and 1250

Mounting version A (standard)

Movable divider:

The arresting cam of the divider can move in the groove of the stay.

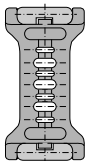

With a movable assembly of the dividers (mounting version A), the holes in the stay do not have any function and hence the dimension a_x -section is meaningless.

Mounting version B

Fixed divider:

The arresting cam of the divider is fixed in the borehole of the stay.

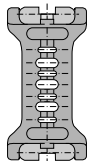

Please note that the dividers can only be fixed in positions at which there is a hole in the stay. The dimension a_x -section specifies the hole intervals in the stay.

Hole intervals = fixing positions of the dividers
(a_x -sections)

By simply turning the stays, it is also possible at any subsequent time to switch between movable and fixed assembly of the dividers (not in case of ME 0320).

Types ME 0320, MK 0475, ME/MK 0650, 0950, 1250

Divider system TS 0

Type	Stay variant	h _i mm	Mounting version A			Mounting version B			
			S _T mm	a _T min mm	a _x min mm	S _T mm	a _T min mm	a _x min mm	a _x section mm
ME 0320	RE	19	2	3	6	2	4.5	8	4
MK 0475	RD	28	2.8	6	7.8	2.8	12	8	8
ME/MK 0650	RE/RD	42	4.2	6.5	13	4.2	13	16	8
ME/MK 0950	RE/RD	58	6	7.5	14.5	6	22.5	16	16
ME/MK 1250	RE/RD	72	8	5	14.5	8	19.5	16	16

In the standard version, the divider systems are mounted on every second chain link.

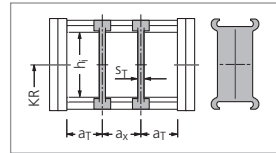

Inside heights



Inside widths



Divider system TS 1 with continuous height subdivision made of aluminium

Type	Stay variant	h _i mm	Mounting version A			Mounting version B				S _H mm	h ₁ mm	h ₂ mm
			S _T mm	a _T min mm	a _x min mm	S _T mm	a _T min mm	a _x min mm	a _x section mm			
ME 0320	RE	19	2	3	6	2	4.5	8	4	2	10	–
MK 0475	RD	28	2.8	6	7.8	2.8	12	8	8	2.4	15	–
ME/MK 0650	RE/RD	42	4.2	6.5	13	–	–	–	–	4	10	22
ME/MK 0950	RE/RD	58	6	7.25	14.5	6	22.5	16	16	4	22	–
ME/MK 1250	RE/RD	72	8	5	14.5	8	19.5	16	16	4	32	–

In the standard version, the divider systems are mounted on every second chain link.

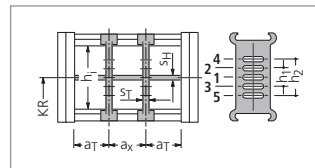

Divider system TS 3

ME/MK 0650, 0950 and 1250 with section subdivision, partitions made of plastic

The dividers for divider system TS 3 do not have any arresting cams. Thus, no mounting version B (fixed mounting) is possible.

Type	Stay variant	h _i mm	S _T mm	a _T min mm	a _x min mm	S _H mm	h ₁ mm	h ₂ mm	h ₃ mm	h ₄ mm
ME 0650	RE/RD	42	8	4	16*	4	14	28	–	–
ME 0950	RE/RD	58	8	4	16*	4	14	28	42	–
ME 1250	RE/RD	72	8	4	16*	4	14	28	42	56

* When using plastic partitions

The dividers are fixed by the partitions, the complete divider system is movable.

In the standard version, the divider systems are mounted on every second chain link.

Divider system TS 2 with fixable dividers (mounting version B) and aluminium height subdivisions in 1 mm width sections is available. Please do get in touch with us.

Dimensions of the plastic partitions for divider system TS 3, see next page.

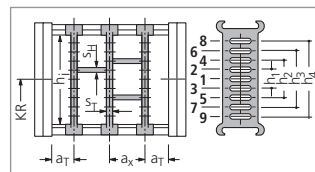

Types ME 0320, MK 0475, ME/MK 0650, 0950, 1250

Dimensions of the plastic partitions for TS 3

Inside heights



Inside widths

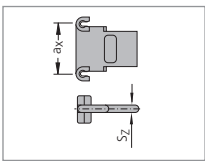

Aluminium partitions in 1 mm width sections are also available.

Sz	a _x (center-to-center dividers)									
	16	18	23	28	32	33	38	43	48	58
4	64	68	78	80	88	96	112	128	144	160
	176	192	208	-	-	-	-	-	-	-

Dimensions in mm

When using partitions with a_x > 112 mm there should be an additional central support with a **twin divider**.

Thickness of the twin dividers: ME/MK 0650 S_T = 3 mm, ME/MK 0950, 1250 S_T = 4 mm

Twin dividers are designed for subsequent fitting in the partition system.

kabelschlepp.de

Gliding elements – the economical solution for gliding applications

Replaceable glide shoes made of plastic*

To extend the life of cable carriers in gliding operations KABELSCHLEPP supplies detachable, exchangeable glide shoes.

Replaceable glide shoes are a very economical solution. When wear occurs only the glide shoes are replaced, and not the complete cable carrier. For travel speeds > 2.5 m/s and large additional loads, a highly wear-resistant special material is used.

For types ME/MK 0950 and 1250 **OFFROAD glide shoes** with 80 % greater wear volumes are also available. We recommend their use in extreme environmental conditions (with particularly abrasive materials such as e. g. sand, dust, corundum).



* not for ME 0320

Chain height with glide shoes:

- MK 0475: h_G' = h_G + 2.5 = 41.5
- ME/MK 0650: h_G' = h_G + 3.2 = 60.2
- ME/MK 0950: h_G' = h_G + 3.5 = 83.5
- ME/MK 1250: h_G' = h_G + 3.5 = 99.5

Dimensions in mm

Minimum bend radii when using glide shoes:

- MK 0475: KR_{min} = 100 mm
- ME/MK 0650: KR_{min} = 95 mm
- ME/MK 0950: KR_{min} = 140 mm
- ME/MK 1250: KR_{min} = 180 mm

By means of a positive snap connection, the glide shoes sit firmly on the chain link.

Font: +49 2762 4003-0

Minimized hinge wear owing to the "life extending 2 disc principle"

In the M Series*, the push and pull forces are transmitted via the optimum link design for this purpose.

As a result link wear is reduced to a minimum and the life of the cable carrier is considerably lengthened.

* not for type 0320

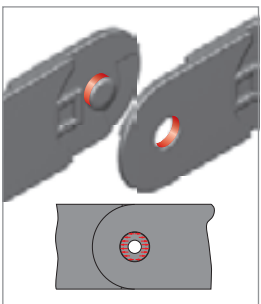

Force transmission with a pin-hole joint

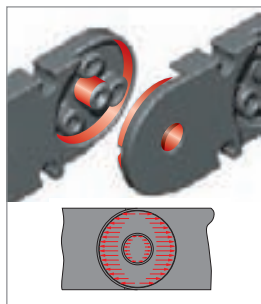

Force transmission with the "life extending 2 disc principle"

Use our free project planning service.

Types ME 0320, MK 0475, ME/MK 0650, 0950, 1250

Connectors made of plastic/aluminium – Type ME 0320

Standard connectors without strain relief.
Connectors with strain relief available on request.

Fixed point connection

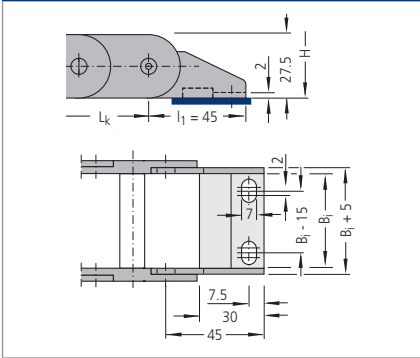

Driver connection

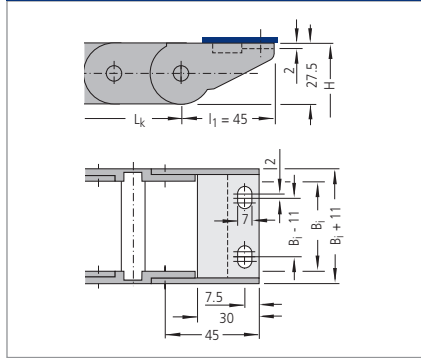

Inside heights



Inside widths



kabelschlepp.de

Connection variants – Type ME 0320

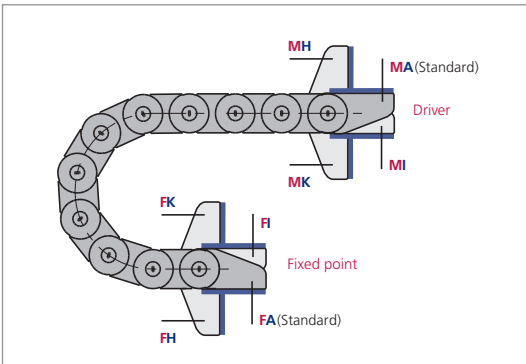

Connection point

- M – Driver
- F – Fixed point

Connection type

- A – Threaded joint outside (standard)
- I – Threaded joint inside
- H – Threaded joint, rotated through 90° to the outside
- K – Threaded joint, rotated through 90° to the inside

In the standard version, the connectors are mounted with the threaded joint outwards (**FA/MA**).

When ordering please specify the desired connection type (see ordering key on page 337).

The connection type can subsequently be altered simply by varying the connectors.

Guide channels
➤ from page 295

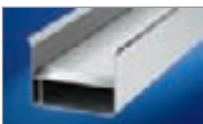

Strain relief devices
➤ from page 302



Cables for cable carrier systems
➤ from page 344



Types ME 0320, MK 0475, ME/MK 0650, 0950, 1250

Connectors made of plastic/steel – Type MK 0475

End connector made of steel plate.
Screwable strain relief made of aluminium on request.

Inside heights



Inside widths

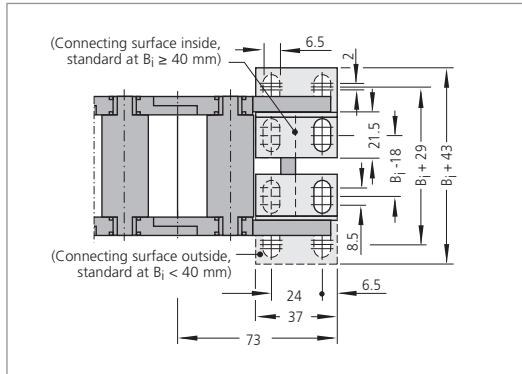
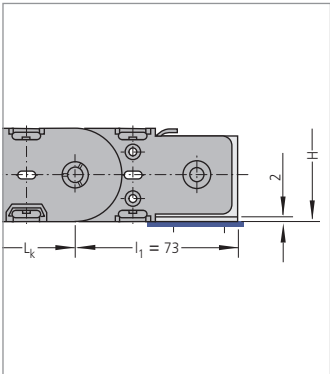

The dimensions of the fixed point and driver connections are identical.

kabelschlepp.de

Fon: +49 2762 4003-0

Connection variants – Type MK 0475

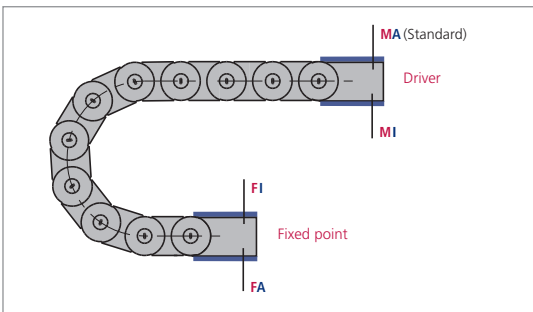

Connection point

- M – Driver
- F – Fixed point

Connection type

- A – Threaded joint outside (standard)
- I – Threaded joint inside

In the standard version, the connectors are mounted with the threaded joint outwards (**FA/MA**).

When ordering please specify the desired connection type (see ordering key on page 337).

The connection type can subsequently be altered simply by varying the connectors.

Use our free project planning service.

Types ME 0320, MK 0475, ME/MK 0650, 0950, 1250

UMB (Universal Mounting Brackets) made of aluminium – Type ME/MK 0650

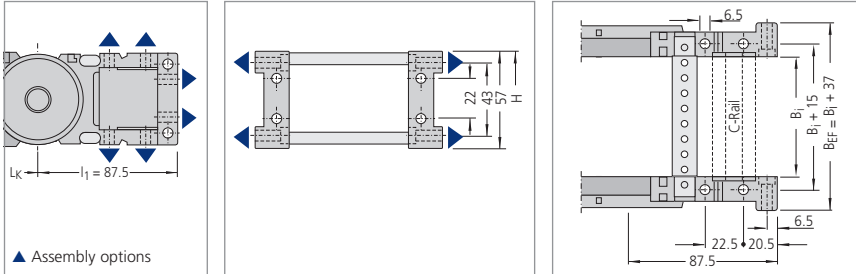

Inside heights

19
72

Inside widths

24
557

The dimensions of the fixed point and driver connections are identical.
End connectors made of steel plate available on request.

Optional C-rails and strain relief elements for cables can be found on the following pages.

When ordering please specify the connection type FU/MU (see ordering key on page 337).

UMB (Universal Mounting Brackets) made of aluminium – Types ME/MK 0950 and 1250

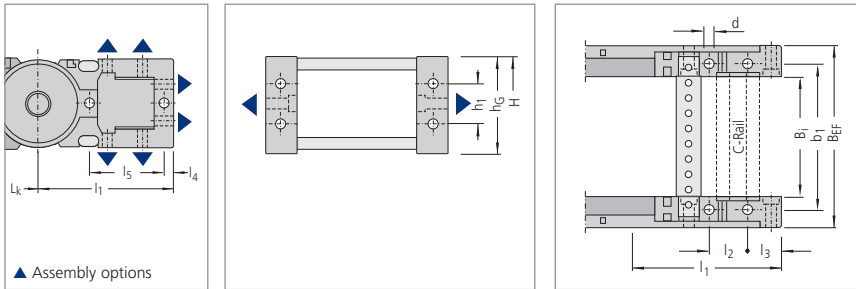

The dimensions of the fixed point and driver connections are identical.
End connectors made of steel plate available on request.

Optional C-rails and strain relief elements for cables can be found on the following pages.

When ordering please specify the connection type FU/MU (see ordering key on page 337).

Type	B _{EF}	b ₁	d	l ₁	l ₂	l ₃	l ₄	l ₅	h ₁	h _G
ME/MK 0950	B _i + 44	B _i + 24.5	8.5	136	35	24.5	8.5	80	45	80
ME/MK 1250	B _i + 51	B _i + 28	11	168	35	31	10.5	94.5	45	96

B_{EF} = Chain width over connector

Dimensions in mm

Types ME 0320, MK 0475, ME/MK 0650, 0950, 1250

Strain relief devices

C-rails for LineFix bracket clamps, SZL strain reliefs and clamps

The optional C-rails are fixed by means of the universal mounting brackets and do not have to be screwed separately.

Please state in your order whether C-rails are needed.

Inside heights

Inside widths

kabelschlepp.de

Fon: +49 2762 4003-0

Use our free project planning service.



■ Universal mounting bracket with C-rail

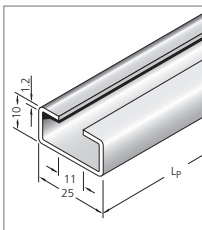

■ **ME/MK 0650:**
Integratable C-rail
25 x 10 mm,
slit width 11 mm,
material steel,
Item-No. 3931

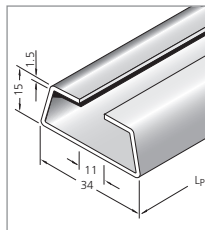

■ **ME/MK 0950 and 1250:**
Integratable C-rail
34 x 15 mm,
slit width 11 mm,
material steel,
Item-No. 3935

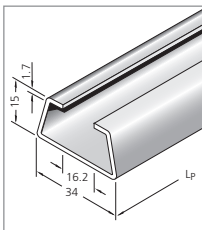

■ **ME/MK 0950 and 1250:**
Integratable C-rail
34 x 15 mm,
slit width 16 – 17 mm,
material aluminium,
Item-No. 3926,
material steel,
Item-No. 3932

Our LineFix strain reliefs are optimally suited for the C-rails. (LineFix bracket clamps and other strain relief devices – see Accessories chapter, from page 302 onwards).



■ C-rail with LineFix strain relief

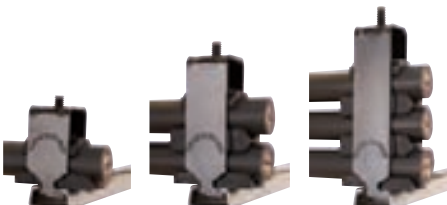

Notes

Inside heights



Inside widths



kabelschlepp.de

Fon: +49 2762 4003-0

OnlineEngineer.de
KABELSCHLEPP
Cable Center Configurator



XL Series

The power to innovate



XL Series

Cable carrier with large inside height

- Large dimensions
- Low intrinsic weight
- TÜV design approved in accordance with 2PFG 1036/10.97



XL Series

Inside height

108

Inside widths

200 - 1000

Selection

BASIC LINE

BASIC LINEPLUS

VARIO LINE

kabelschlepp.de

Fon: +49 2762 4003-0

OnlineEngineer.de
KABELSCHLEPP
 Cable Carrier Configurator

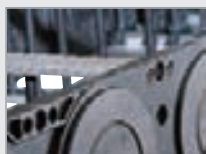

Bolted stays and cover systems for maximum stability even with large carrier widths



Replaceable glide shoes for long service life for gliding applications



Stable end connector made of steel (different connection variants)

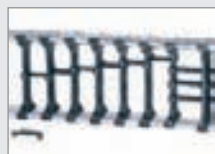

Many separation options for the cables

Type XLC 1650

with aluminium stays

- Available in 1 mm width sections

WIDTHSECTIONS



Inside height



Inside widths



Type	h _i	B _i	Maximum travel length in m	Dynamics of unsupported arrangement		Page
				Travel speed v _{max} in m/s	Travel acceleration a _{max} in m/s ²	
XLC 1650	108	200-1000	350	4	25	183

Dimensions in mm

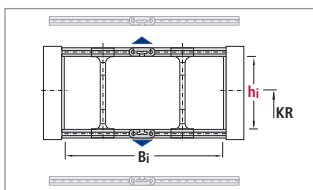

kabelschlepp.de

Stay variants

Frame stay RM

Solid design

Bolted, maximum stability, maximum chain widths possible.



Additional stay variants:

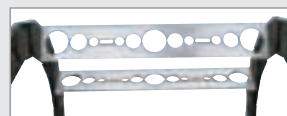

Stay variant LG made of aluminium:

Optimum cable routing in the neutral bending line



Stay variant RMR: Gentle cable laying by means of rollers. Ideal for hydraulics hoses with "soft" jackets

Stay arrangement

Standard: on every 2nd chain link

The stays can be mounted on every chain link, please specify when placing your order.



Use our free project planning service.

Font:

+49 2762 4003-0

TUBE SERIES – covered cable carriers

Type XLT 1650 with aluminium cover system



Inside height

108

Inside widths

200
-
1000

kabelschlepp.de

Fon:

+49 2762 4003-0

OnlineEngineer.de
KABELSCHLEPP
Cable Carrier Configurator

Type XLC 1650

Dimensions and intrinsic chain weight

Type	Stay variant	h _j	h _G	B _i min	q _k min	B _i max	q _k max	B _k
XLC 1650	RM	108	140	200	10.5	1000	15.3	B _i + 68

Dimensions in mm/Weights in kg/m

WIDTH SECTIONS
1 mm

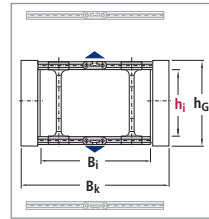

Bend radius and pitch

Type	Bend radii KR mm						
XLC 1650	250	300	350	400	450	500	550

Pitch t = 165 mm

Load diagram

for unsupported length L_f depending on the additional load

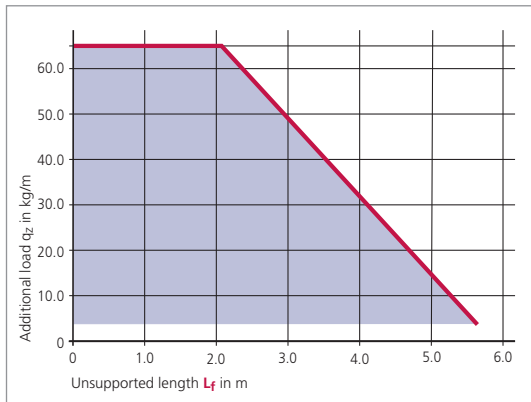

Unsupported length L_f

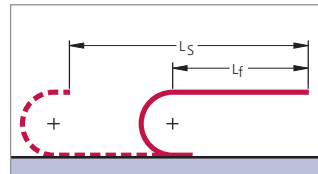

In the case of longer travel lengths, sag of the cable carriers is technically permissible depending on the application.

In a gliding arrangement, even longer travel lengths are possible (see page 295).

We are at your service to advise on these applications.

Example of ordering

Cable carrier					Divider system		Connection
XLC 1650	600	RM	350	4125	TS 0	4	FA/MA
Type	Inside width B _i in mm	Stay variant	Bend radius KR in mm	Chain length* L _k in mm (without connection)	Divider system	Number of dividers n _T	Connection Fixed point/Driver

Ordering divider systems:

Please state the designation of the divider system (TS 0, TS 1 ...) and the number of dividers. Possibly attach a sketch with the dimensions.

* The calculated chain length L_k **must** always be rounded to an odd number of chain links.

Type XLC 1650

Divider system TS 0

Inside height

108

Inside widths

200
1000

Type	Stay variant	h_i mm	S_T mm	a_T min mm	a_x min mm
XLC 1650	RM	108	8	6	25

The dividers can be moved in the cross section.

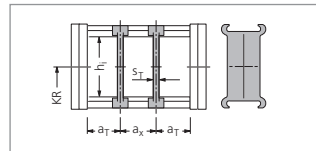

In the standard version, the divider systems are mounted on every second chain link.

Divider system TS 3 with section subdivision, partitions made of plastic

Type	Stay variant	h_i mm	S_T mm	a_T min mm	a_x min mm	S_H mm	h_1 mm	h_2 mm	h_3 mm	h_4 mm	h_5 mm
XLC 1650	RM	108	8	1	16*	4	14	28	42	56	70

* When using plastic partitions

The dividers are fixed by the partitions, the complete divider system is movable.

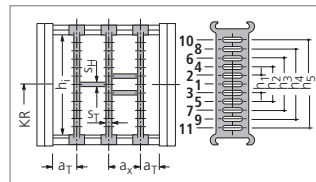

In the standard version, the divider systems are mounted on every second chain link.

Fon: +49 2762 4003-0

Dimensions of the plastic partitions for TS 3

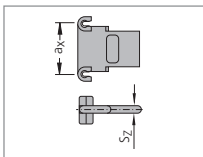

S_T	a_x (center-to-center dividers)									
	4	16	18	23	28	32	33	38	43	48
	64	68	78	80	88	96	112	128	144	160
	176	192	208	-	-	-	-	-	-	-

Dimensions in mm

Aluminium partitions in 1 mm width sections are also available.

When using **partitions with $a_x > 112$ mm** there should be an additional central support with a **twin divider** ($S_T = 5$ mm).
Twin dividers are designed for subsequent fitting in the partition system.

Use our free project planning service.

Guide channels
➤ from page 295



Strain relief devices
➤ from page 302



Cables for cable carrier systems
➤ from page 344



Type XLC 1650

Gliding elements – the economical solution for gliding applications

Replaceable glide shoes made of plastic

To extend the life of cable carriers in gliding operations KABELSCHLEPP supplies detachable, exchangeable glide shoes. Replaceable glide shoes are a very economical solution. When wear occurs only the glide shoes are replaced, and not the complete cable carrier.

Chain height with glide shoes:

$$h_G' = 147 \text{ mm}$$



Inside height

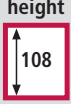

Inside widths



! By means of a positive snap connection, the glide shoes sit firmly on the chain link.

Connection dimensions

End connector made of steel plate

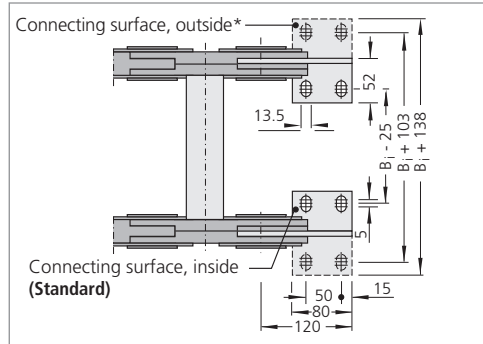
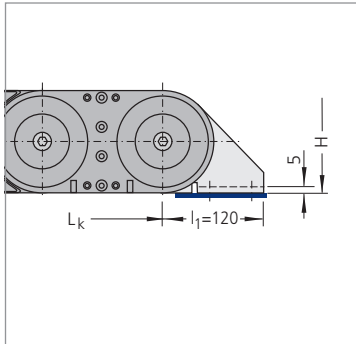

The dimensions of the fixed point and driver connections are identical.

* Please specify when ordering.

Connection variants

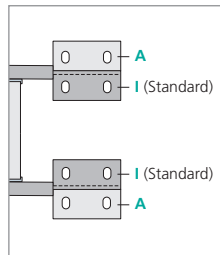
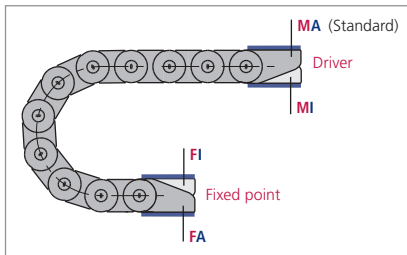

The connecting surfaces on the driver and fixed point can be mounted on the outside or inside according to preference.

Connection point Connection type

- M** – Driver
- F** – Fixed point
- A** – Threaded joint outside (standard)
- I** – Threaded joint, inside

Connecting surface

- I** – Connecting surface inside (< B_k)
- A** – Connecting surface outside (> B_k)

In the standard version, the end connectors are mounted with the threaded joint outwards (**FAI/MAI**). When ordering please specify the desired connection type (see ordering key on page 337).

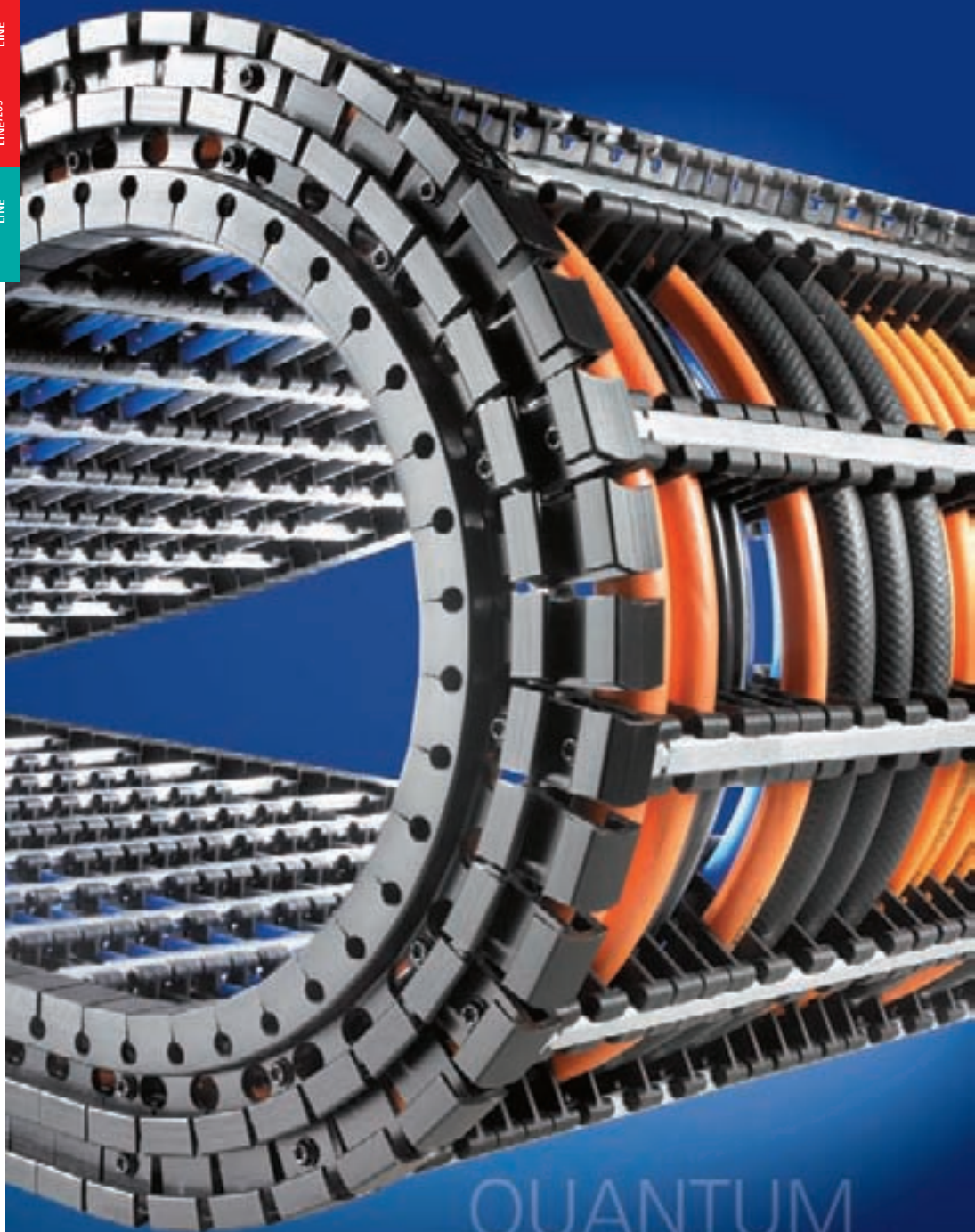

QUANTUM
The power to innovate

QUANTUM

Light, extremely quiet and low-vibration for high speeds and accelerations*

- **Suitable for clean rooms:**
Clean room certification "Class 1" possible – no hinges, no link wear**
- Extremely quiet, 31 db (A)***
- Extremely lightweight
- For high accelerations up to 300 m/s²
- For travel speeds up to 40 m/s
- Very long service life:
25 million cycles = unsurpassed service life
- TÜV design approved in accordance with 2PFG 1036/10.97

** Tested: Q040.77.RE-70-1000 by the Fraunhofer Institute, travel speed V1 = 0.2 m/s and V2 = 0.9 m/s

*** Tested: Q060.100.100 by TÜV Rheinland. The measurement area sound pressure level was measured at a distance of 0.5 m for uniform and jerky movement.

C-Rail for strain relief elements or strain relief comb

Replaceable glide shoes

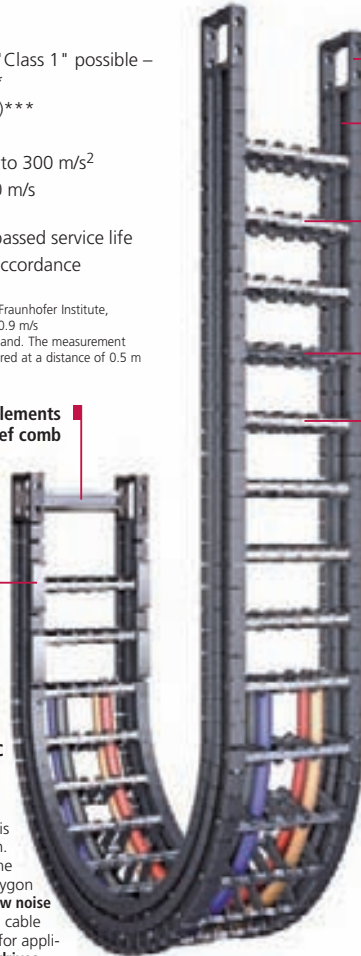

Universal connectors (UMB)

Extremely low-noise and low-vibration operation

Aluminium stays available in 1 mm width sections

WIDTH SECTIONS



Plastic stays available in 8 or 16 mm width sections

Large choice of stay systems and ways of separating the cables

ALMOST NO POLYGON EFFECT

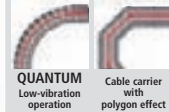

QUANTUM Low-vibration operation

Cable carrier with polygon effect

Ideal for highly dynamic applications – extruded side bands

The operation of the QUANTUM is extremely quiet and low-vibration. Due to the link-free design and the very small pitch, the so-called polygon effect is minimized. Due to the **low noise** during operation, the QUANTUM cable carrier system is optimally suited for applications with **low-vibration linear drives**.

Suitable for clean rooms and long service life

Extruded sidebands are installed. In contrast to conventional pin-hole joints, there is almost no wear (link wear), whereby QUANTUM is excellent for use in clean rooms.

Extremely long service life due to

- No link wear on pin-hole joints
- Special plastic and steel cables in the supporting base

Inside heights



Inside widths



kabelschlepp.de

Font: +49 2762 4003-0

OnlineEngineer.de
KABELSCHLEPP
Cable Carrier Configurator



Ideal for highly dynamic applications



3D movements: The driver connection can move sideways and can be turned through up to ± 30 degrees



Side bands made of extruded special plastic and steel cables in the supporting base for extremely long service life



Types Q 040, Q 060, Q 080 and Q 100

with plastic or aluminium stays

- Available in 1 mm width sections (aluminium stays)

WIDTH SECTIONS



- Available in 8 or 16 mm width sections (plastic stays)

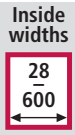
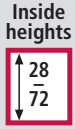

kabelschlepp.de

Fon: +49 2762 4003-0

Use our free project planning service.

Type	h _i	B _i	Maximum travel length in m	Dynamics of unsupported arrangement		Page
				Travel speed v _{max} in m/s	Travel acceleration a _{max} in m/s ²	
Q 040	28	28-284	100	40	300	189
Q 060	42*	38-500	150	30	160	189
Q 080	58	50-600	180	25	100	189
Q 100	72	70-600	200	20	70	189

* with stay variant RE

Dimensions in mm

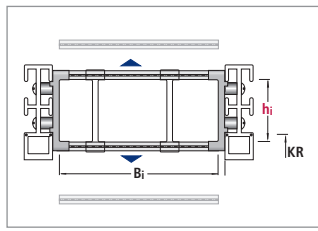

Stay variants

Frame stay RS made of aluminium
Standard design – Q 060, Q 080, Q 100

For lightweight to medium loads.
Opening options:
Outside/Inside: can be opened quickly and easily simply by rotating the stays through 90°.

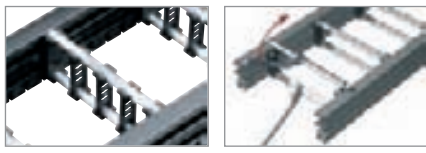

Frame stay RV made of aluminium
Reinforced design – Q 080, Q 100

For medium to heavy loads and for large chain widths.
Opening options:
Outside/Inside: can be opened quickly and easily simply by rotating the stays through 90°.



Frame stay RE made of plastic
Q 040, Q 060, Q 080, Q 100
Opening options:
Outside/Inside: simply by turning (through 90°).



Types Q 040, Q 060, Q 080 and Q 100

Dimensions and intrinsic weight

"Hybrid designs" with aluminium stay systems

Type	Stay variant	h _i	h _G	B _i min	q _k min	B _i max	q _k max	B _k
Q 060	RS	38	60	38	1.25	500	2.40	B _i + 52
Q 080	RS	58	80	50	1.90	600	2.25	B _i + 72
Q 080	RV	58	80	50	2.10	600	2.90	B _i + 72
Q 100	RS	72	98	70	2.60	600	3.40	B _i + 82
Q 100	RV	72	98	70	2.80	600	4.60	B _i + 82

Dimensions in mm/Weights in kg/m

"Plastic designs"

Type	Stay variant	h _i	h _G	B _i min	q _k min	B _i max	q _k max	B _k	Width section
Q 040	RE	28	40	28	0.63	284	0.98	B _i + 40	8
Q 060	RE	42	60	68	1.16	276	1.54	B _i + 52	8
Q 080	RE	58	80	58	1.93	570	2.70	B _i + 72	16
Q 100	RE	72	98	74	2.74	570	3.67	B _i + 82	16

Dimensions in mm/Weights in kg/m

WIDTH SECTIONS

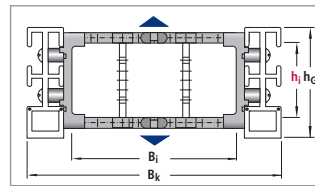
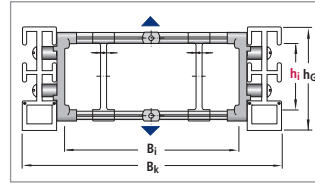

Inside heights



Inside widths



kabelschlepp.de

Bend radius and pitch

Type	Bend radii KR mm					
Q 040	60	75	90	110	150	180
Q 060	100	120	150	190	250	300
Q 080	170	200	250	320	420	500
Q 100	180	250	300	370	460	600

Pitch:

- Q 040: t = 15 mm
- Q 060: t = 20 mm
- Q 080: t = 25 mm
- Q 100: t = 30 mm

Load diagram

for length with permissible (desired) sag L_D depending on the additional load

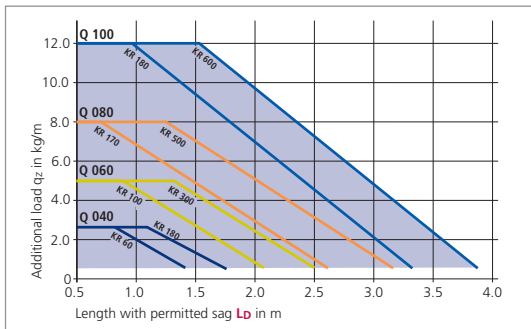

Length with permissible sag L_D and travel length L_S

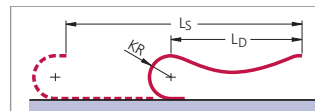

In the case of long travel lengths, the cable carriers are placed in a guide channel with the upper trough gliding on the lower trough (see page 295).

We are at your service to advise on these applications.

Fon: +49 2762 4003-0

Example of ordering

Cable Carrier

Q 060 - 200 - RS - 150 - 1540

Type Inside width B_i in mm Stay variant Bend radius KR in mm Chain length L_k in mm (without connection)

Divider system

TS 0 / 2

Divider system Number of dividers n_T

Connection

FU/MU

Connection Fixed point/Driver

Ordering divider systems:

Please state the designation of the divider system (TS 0, TS 1 ...) and the number of dividers. Possibly attach a sketch with the dimensions.

Types Q 040, Q 060, Q 080 and Q 100

Divider system TS 0

Inside heights



Inside widths



Type	Stay variant	h _i mm	S _T mm	a _T min mm	a _x min mm
Q 040	RE	28	2.8	8	8
Q 060	RS	38	3	13.5	13
Q 060	RE	42	4.2	14	13
Q 080	RS	58	4	11	14
Q 080	RV	58	4	11	14
Q 080	RE	58	6	12	14.5
Q 100	RS	72	5	11	14
Q 100	RV	72	6	13	16
Q 100	RE	72	8	12	14.5

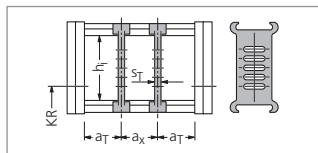

Standard mounting distances of the divider systems:

Q 040, Q 060: on every 6th pitch division
 Q 080, Q 100: on every 8th pitch division

In the standard version, the dividers are movable.
 In the case of plastic stays (stay variant RE), the dividers can also be mounted fixed (note the mounting distances).

kabelschlepp.de

Divider system TS 1 with continuous height subdivision made of aluminium

Type	Stay variant	h _i mm	S _T mm	a _T min mm	a _x min mm	S _H mm	h ₁ mm	h ₂ mm	h ₃ mm
Q 040	RE	28	2.8	8	8	2.4	15	-	-
Q 060	RS	38	3	13.5	13	4	15	-	-
Q 060	RE	42	4.2	14	13	2	10	-	-
Q 080	RS	58	4	11	14	4	30	-	-
Q 080	RV	58	4	11	14	4	15	30	-
Q 080	RE	58	6	12	14.5	4	22	-	-
Q 100	RV	72	6	13	16	4	15	30	45
Q 100	RE	72	8	12	14.5	4	32	-	-

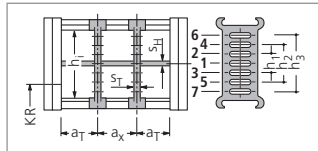

Standard mounting distances of the divider systems:

Q 040, Q 060: on every 6th pitch division
 Q 080, Q 100: on every 8th pitch division

In the standard version, the dividers are movable.
 In the case of plastic stays (stay variant RE), the dividers can also be mounted fixed (note the mounting distances).

Fon: +49 2762 4003-0

Use our free project planning service.

Guide channels
 ▶ from page 295



Strain relief devices
 ▶ from page 302



Cables for cable carrier systems
 ▶ from page 344



Types Q 040, Q 060, Q 080 and Q 100

Divider systems TS 2 and TS 3

Q 040 with divider system TS 2 with grid subdivision made of aluminium available in 8 mm section widths.

Q 060, Q 080 and Q 100 with divider system TS 3 with section subdivision, partitions made of plastic
For these types, divider system TS 2 with grid subdivision made of aluminium (1 mm grid) is also available.

Type	Stay variant	h _i mm	S _T mm	a _T min mm	a _x min mm	S _H mm	h ₁ mm	h ₂ mm	h ₃ mm	h ₄ mm
Q 040 ^{A)}	RE	28	2,8	14	8	2,4	15	–	–	–
Q 060 ^{B)}	RS	38	8	11	16*	4	14	–	–	–
Q 060 ^{B)}	RE	42	8	11	16*	4	14	28	–	–
Q 080 ^{B)}	RV	58	8	8	16*	4	14	28	42	–
Q 080 ^{B)}	RE	58	8	8	16*	4	14	28	42	–
Q 100 ^{B)}	RV	72	8	8	16*	4	14	28	42	56

* When using plastic partitions

A) Only fixed mounting of the divider is possible, and at 8 mm intervals (also see mounting version B in Chapter ME/MK).

B) The dividers are fixed by the partitions, the complete divider system is movable.

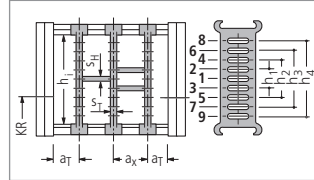

Standard mounting distances of the divider systems:

Q 040, Q 060: on every 6th pitch division

Q 080, Q 100: on every 8th pitch division

Inside heights



Inside widths



kabelschlepp.de

Dimensions of the plastic partitions for TS 3

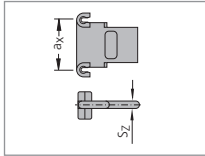

S _Z	a _x (center-to-center distance, dividers)									
	4	16	18	23	28	32	33	38	43	48
64		68	78	80	88	96	112	128	144	160
176		192	208	–	–	–	–	–	–	–

Dimensions in mm

Aluminium partitions in 1 mm width sections are also available.

When using partitions with a_x > 112 mm there should be an additional central support with a twin divider.

Twin dividers are designed for subsequent fitting in the partition system.

Fon: +49 2762 4003-0

Gliding elements – the economical solution for gliding applications

Replaceable glide shoes made of plastic*

To extend the life of cable carriers in gliding operations KABELSCHLEPP supplies detachable, exchangeable glide shoes. Replaceable glide shoes are a very economical solution. When wear occurs only the glide shoes are replaced, and not the complete cable carrier.

* not for Q 040

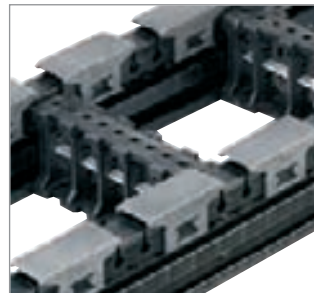

Dimensions with glide shoe

Type	Height h _G '	Width B _{EF} '
Q 060	h _G ' = h _G + 6 = 66	B _i + 56.0
Q 080	h _G ' = h _G + 8 = 88	B _i + 79.5
Q 100	h _G ' = h _G + 10 = 108	B _i + 89.5

Dimensions in mm

! By means of a positive snap connection, the glide shoes sit firmly on the chain link.

OnlineEngineer.de
KABELSCHLEPP
Cable Carrier Configurator

Types Q 040, Q 060, Q 080 and Q 100

UMB (Universal Mounting Brackets) made of aluminium

Inside heights



Inside widths

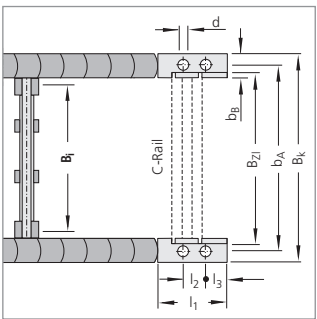
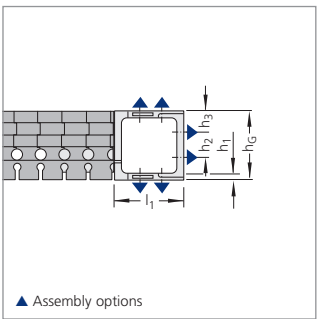

▲ Assembly options

The dimensions of the fixed point and driver connections are identical. The connecting elements make the last 3 pitch divisions at both ends of each sideband immobile. When ordering please specify the connection type FU/MU (see ordering key on page 337).

kabelschlepp.de

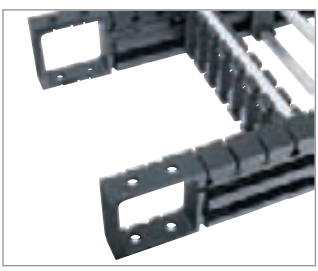

Fon: +49 2762 4003-0

Connection dimensions:

Type	BzL	b _a	B _k	d	l ₂	l ₃	l ₁	h ₁	h ₂	h ₃	h _G	b _B
Q 040	B _i + 16	B _i + 26	B _i + 40	7	14	13.0	40	5	14	13.0	40	14
Q 060	B _i + 18	B _i + 32	B _i + 52	7	25	17.5	60	5	25	17.5	60	20
Q 080	B _i + 30	B _i + 47	B _i + 72	9	35	22.5	80	8	35	22.5	80	25
Q 100	B _i + 30	B _i + 52	B _i + 82	11	35	32.5	100	10	35	31.5	98	30

Dimensions in mm

Strain relief devices

Strain relief comb made of aluminum on one side (QUANTUM 040, 060)

The cables can be fixed securely and simply using the **optional strain relief combs**. The strain relief combs are installed between the UMBS, and do not need to be bolted on separately or mounted on a C-Rail.

Please state on the order whether strain relief combs are needed.



Use our free project planning service.

Types Q 040, Q 060, Q 080 and Q 100

Strain relief devices

Strain relief combs made of plastic on both sides (QUANTUM 060)

The cables can be fixed securely and simply using the **optional strain relief combs**.

The strain relief combs are installed between the UMBs, and do not need to be bolted on separately or mounted on a C-Rail.

Please state on the order whether strain relief combs are needed.

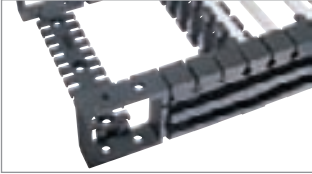

■ Universal mounting bracket with strain relief comb



■ Both-sided strain relief comb

Type	B _i mm	n _z
Q 060	44	5
Q 060	49	5
Q 060	69	7
Q 060	74	7
Q 060	89	8
Q 060	94	9
Q 060	99	9
Q 060	119	11

Type	B _i mm	n _z
Q 060	124	11
Q 060	144	13
Q 060	149	13
Q 060	169	15
Q 060	174	15
Q 060	199*	17
Q 060	224*	19

n_z = Number of teeth on one side of the comb
* on request

Inside heights



Inside widths



kabelschlepp.de

C-rails for LineFix bracket clamps, SZL strain reliefs and clamps

The optional C-rails are fixed by means of the universal mounting brackets and do not have to be screwed separately. **Please state in your order whether C-rails are needed.**



■ Universal mounting bracket with C-rail

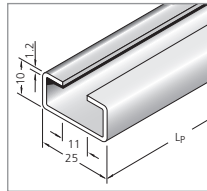

■ **QUANTUM 060:**
Integratable C-rail
25 x 10 mm,
slit width 11 mm,
material steel,
Item-No. 3931

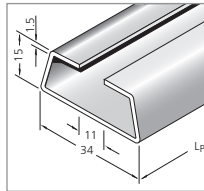

■ **QUANTUM 080, 100:**
Integratable C-rail
34 x 15 mm,
slit width 11 mm,
material steel,
Item-No. 3935

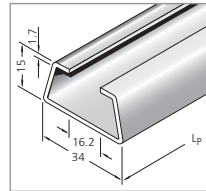

■ **QUANTUM 080, 100:**
Integratable C-rail
34 x 15 mm,
slit width 16 – 17 mm,
material aluminium,
Item-No. 3926,
material steel,
Item-No. 3932

Font:
+49 2762 4003-0

Our LineFix strain reliefs are optimally suited for the C-rails. (LineFix bracket clamps and other strain relief devices – see Accessories chapter, from page 302 onwards).



■ C-rail with LineFix strain relief

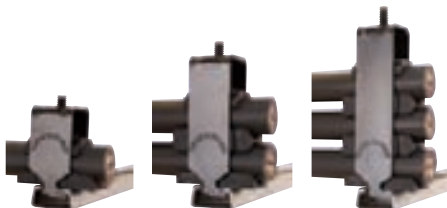



IKR 0200
The power to innovate



product
design
award

2006



TKR 0200

Extremely quiet and low-vibration for highly dynamic applications

- Long service life
- Ideal for highly dynamic applications
- High lateral stability
- Suitable for clean rooms
- Simple shortening and extension due to modular design

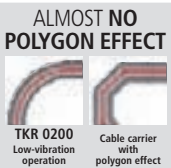
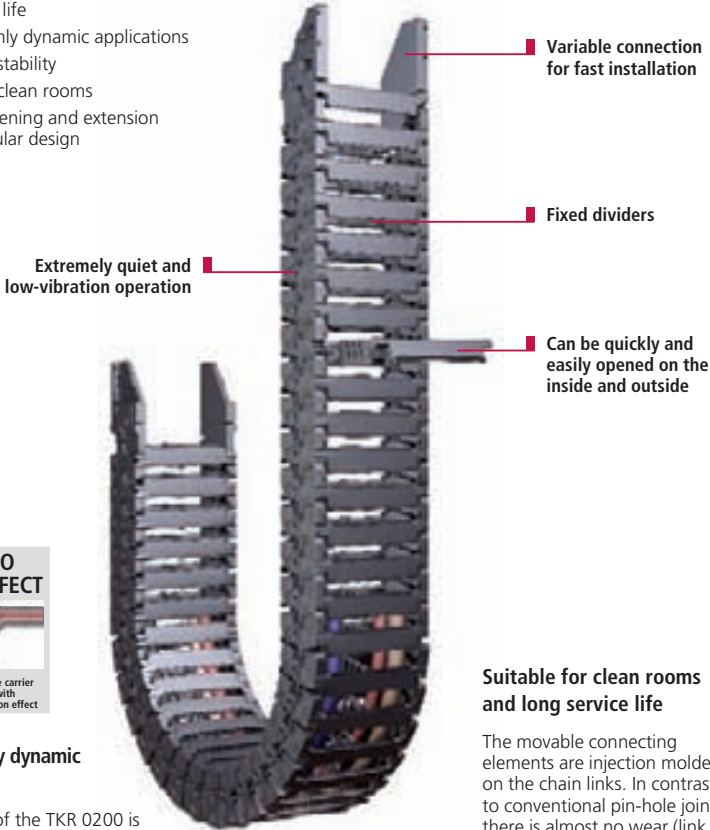

Ideal for highly dynamic applications

The operation of the TKR 0200 is extremely low-noise and low-vibration. The so-called polygon effect is minimized. Optimum uses are especially handling and installation systems, robots, measuring equipment, automatic pick and place systems, printing and textile machines.

Due to their **low noise** during operation, the TKR 0200 types are optimally suitable for applications with **low-vibration linear drives**.

Suitable for clean rooms and long service life

The movable connecting elements are injection molded on the chain links. In contrast to conventional pin-hole joints, there is almost no wear (link wear), whereby the TKR types are excellent for use in clean rooms.

The special shaping of the connecting elements also increases the service life of the system.



Ideal for highly dynamic applications



Variable connection with rotatable connectors



The modular design makes it easy to shorten and lengthen



Injection molded connecting elements

TKR 0200

Inside height

28

Inside widths

40 - 100

Selection

BASIC LINE

BASIC LINE PLUS

VARIO LINE

kabelschlepp.de

Font: +49 2762 4003-0

OnlineEngineer.de
KABELSCHLEPP
Cable Carrier Configurator

TKR 0200

Solid plastic cable carrier



Inside height



Inside widths



Type	h _i	B _i	Maximum travel length in m	Dynamics of unsupported arrangement		Page
				Travel speed v _{max} in m/s	Travel acceleration a _{max} in m/s ²	
TKR 0200	28	40-100	2.8	10*	200*	196

* Possible maximum values: Please contact us. Dimensions in mm

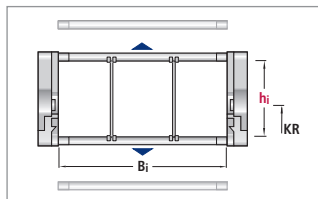

Dimensions and intrinsic weight

Type	h _i	h _G	Inside width B _i				B _k
			Intrinsic chain weight				
TKR 0200	28	35	40	60	80	100	B _i + 16
			0.6	0.7	0.8	0.9	

Dimensions in mm/Weights in kg/m

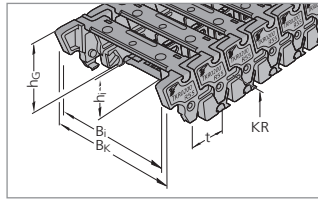

kabelschlepp.de

Bend radius and pitch

Bend radii KR mm			
55	75	95	150

Pitch t = 20.0 mm

Load diagram

for unsupported length L_f depending on the additional load

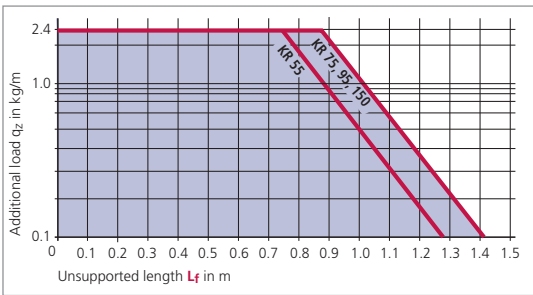

Unsupported length L_f

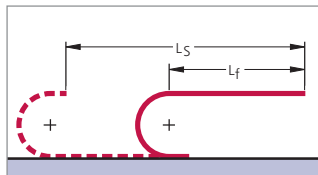

In the case of longer travel lengths, sag of the cable carriers is technically permissible depending on the application.

We are at your service to advise on these applications.

Example of ordering

Cable Carrier	Divider system	Connection
TKR 0200 - 100 - 95 - 800	TS 0 / 3	FA/MA
Type	Divider system	Connection
Inside width B _i in mm	Number of dividers n _T	Fixed point/Driver
Bend radius KR in mm		
Chain length L _k in mm (without connection)		

Ordering divider systems:

Please state the designation of the divider system (TS 0, TS 1 ...) and the number of dividers. Possibly attach a sketch with the dimensions.

Fon: +49 2762 4003-0

Use our free project planning service.

TKR 0200

Divider system TS 0

Type	h _i mm	S _T mm	a _T min* mm	a _x min mm	a _x section mm
TKR 0200	28	2	14/16	8	4

* a_T min = 14 mm for B_i = 60, 100 a_T min = 16 mm for B_i = 40, 80

The dividers are fixed in the cross section.



■ Fixed dividers

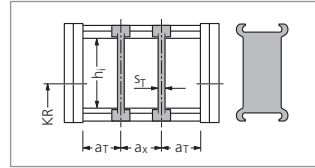

In the standard version, the divider systems are mounted on every second chain link.

Inside height



Inside widths



Divider system TS 1 with continuous height subdivision made of aluminium

Type	h _i mm	S _T mm	a _T min* mm	a _x min mm	S _H mm	h ₁ mm	a _x section mm
TKR 0200	28	2	14/16	8	4	13	4

* a_T min = 14 mm for B_i = 60, 100 a_T min = 16 mm for B_i = 40, 80

The dividers are fixed in the cross section.



■ Fixed dividers

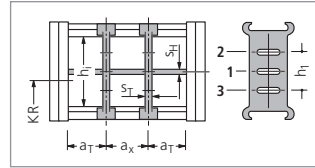

In the standard version, the divider systems are mounted on every second chain link.

kabelschlepp.de

Plastic connectors

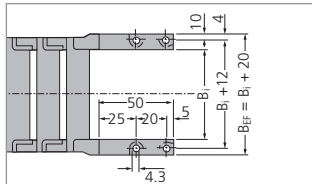
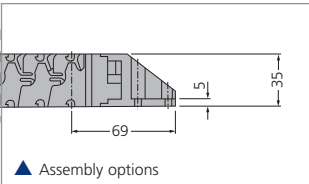

The dimensions of the fixed point and driver connections are identical.

Connection variants

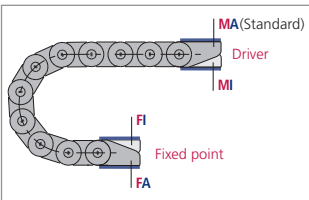

Connection point

- M** – Driver
- F** – Fixed point

Connection type

- A** – Threaded joint outside (standard)
- I** – Threaded joint, inside

Easy rotation of the connectors for inside and outside connection



Subject to change.

OnlineEngineer.de
Web-Configurator
 Cable Carriers Configurator

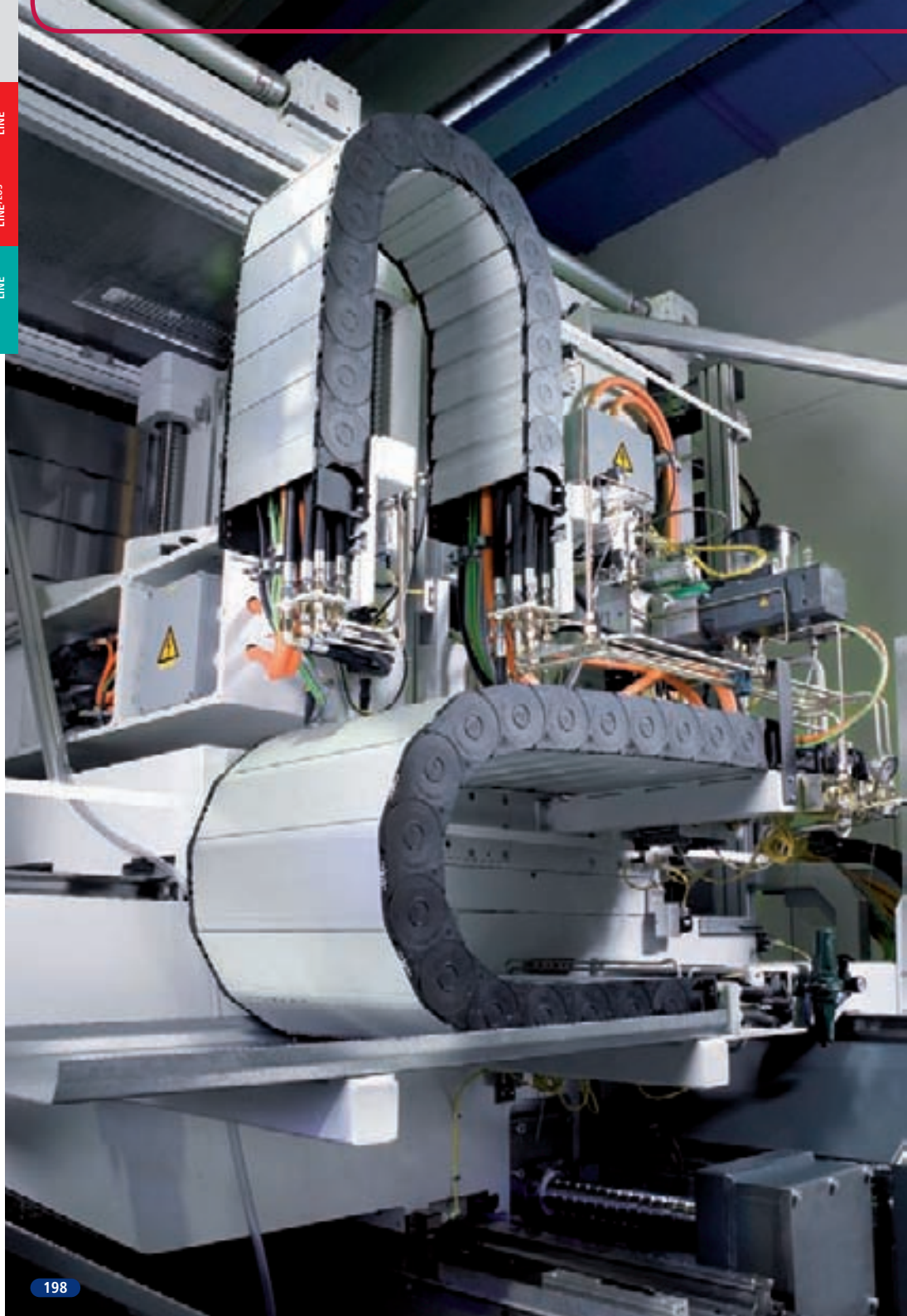

TUBE SERIES

Covered Cable Carriers

- Covered cable and hose carriers with plastic or aluminium cover systems and completely enclosed carrier tubes
- For protection of the cables for applications where chips or severe contamination occur



CoverTrax

Extreme cable protection in harsh environmental conditions

page 200



UNIFLEX TUBES

Proven solid cable carriers with fixed carrier widths

page 208



MASTER TUBES

Quiet and weight-optimized cable carriers

page 218



MT Series

Multivariable cable carrier with extensive accessories

page 228



XLT Series

Cable and hose carrier with large inside height

page 237



S/SX Series

Extremely robust and stable steel chains

page 241



CONDUFLEX

Closed designer cable carrier

page 242



MOBIFLEX

Enclosed cable carrier with flexible metal helical tube

page 243

CoverTrax
The power to innovate

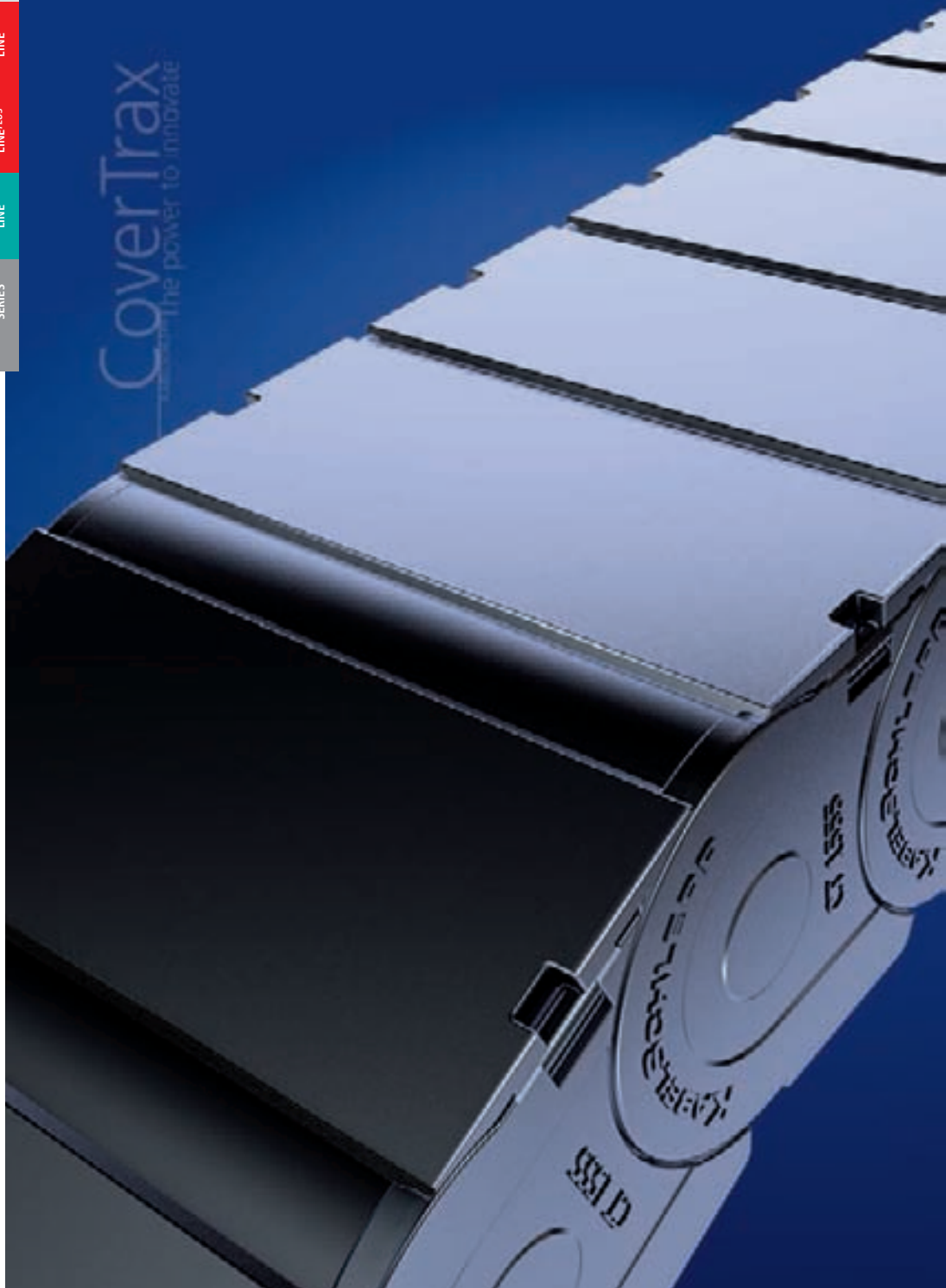

CoverTrax

Extreme cable protection in harsh environmental conditions

- outstanding protection for the cables
- quick cable laying – inside and outside opening designs
- very quiet thanks to internal noise damping system
- large unsupported length
- high-quality visual design
- for unsupported and gliding arrangements

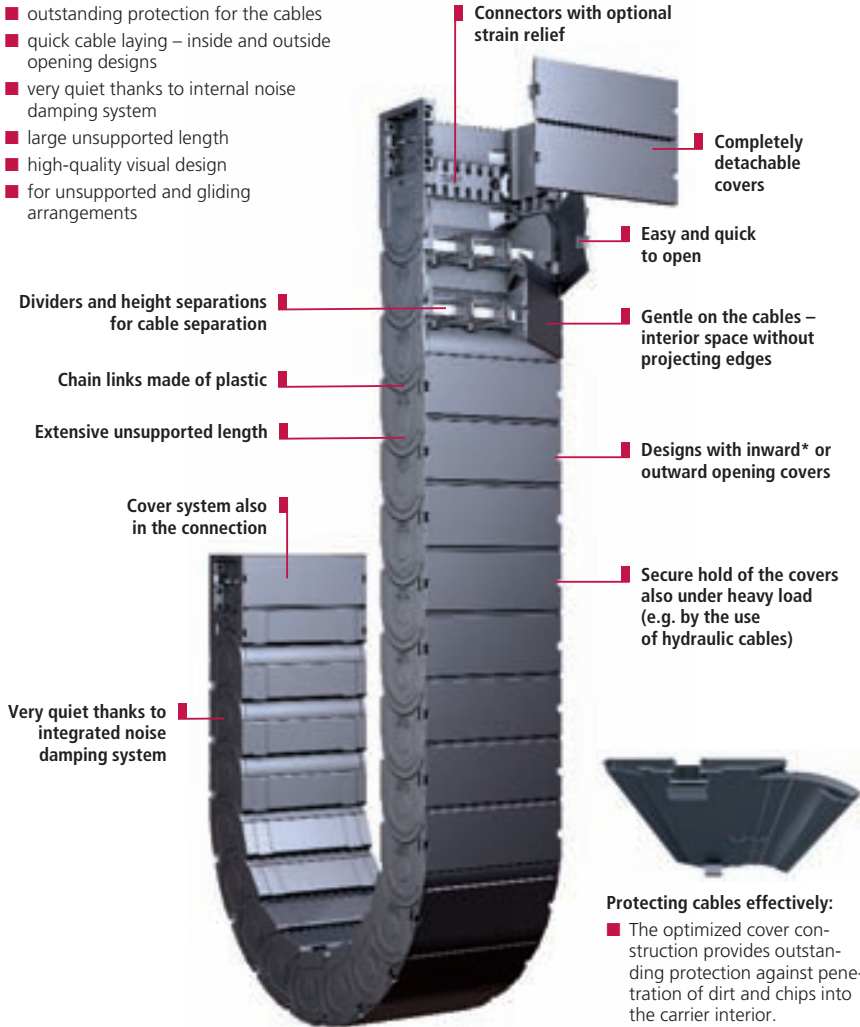

Inside heights



Inside widths



kabelschlepp.de

Fon: +49 2762 4003-0

Protecting cables effectively:

- The optimized cover construction provides outstanding protection against penetration of dirt and chips into the carrier interior.



Simply unlock cover with a screwdriver



Detach the cover from the chain link



Divider system TS 1



Optional strain relief comb – also placed on top of one another

Overview CoverTrax

Design 060 with a cover that can be levered open to the inside*

Inside heights



Inside widths

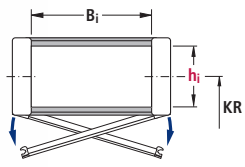

kabelschlepp.de

Type	h_i	B_i	Maximum travel length in m	Dynamics of unsupported arrangement		Page
				Travel speed v_{max} in m/s	Travel acceleration a_{max} in m/s^2	
CT 1555.060	50	50-250	100	6	35	204

Dimensions in mm

Fon: +49 2762 4003-0

Bauart 080 with a cover that can be levered open to the outside

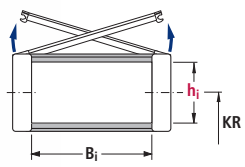

Type	h_i	B_i	Maximum travel length in m	Dynamics of unsupported arrangement		Page
				Travel speed v_{max} in m/s	Travel acceleration a_{max} in m/s^2	
CT 1555.080	50	50-250	100	6	35	204

Dimensions in mm

Use our free project planning service.

* On request – please contact us.

Extreme cable protection – CoverTrax 1555

The CoverTrax cable carrier provides outstanding protection for the routed cables and hoses. It has been developed for harsh environmental conditions with chips, dirt and dust and effectively prevents foreign bodies from entering the cable space. The optimized geometry of the chain links makes the carrier very stable, with a large unsupported length. The integrated damping system makes it very quiet. The new CoverTrax 1555 is not just remarkable for its technical attributes, but also for its new visual design, with its impressive style and functionality. For example, the almost completely smooth side band contour of the individual chain links presents hardly any gap through which foreign bodies could penetrate.

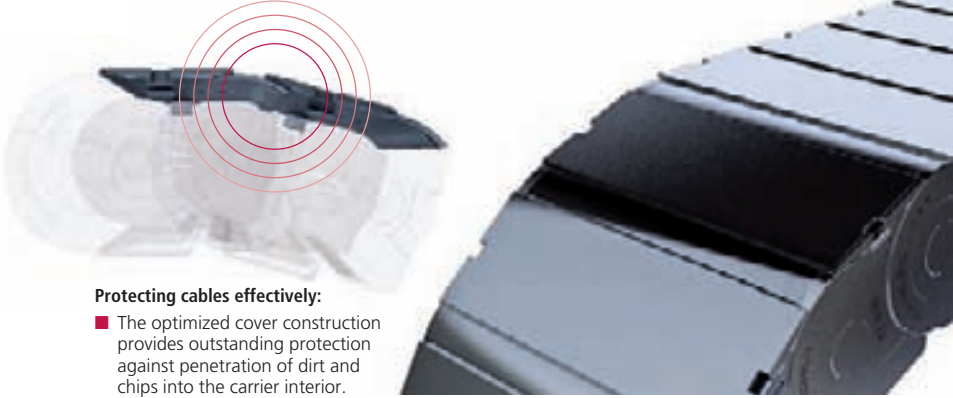

Protecting cables effectively:

- The optimized cover construction provides outstanding protection against penetration of dirt and chips into the carrier interior.

Inside heights



Inside widths



kabelschlepp.de

Optimized geometry

The protection for the routed cables has been optimized by means of design features. Extremely small gap dimensions and the new geometry effectively prevent the penetration of foreign bodies.



- The reinforced contour of the new cover provides extremely small gap dimensions even with large carrier widths.
- The openable covers reach above the side band and deflect dirt off to the side.
- Smooth side band contour with encapsulated stroke system.

Font: +49 2762 4003-0

Easy connection – optionally with strain relief comb

With the UMB connectors you can connect the CoverTrax easily from **above**, from **below** or at **the front**. The **optional C-rails** and **Linefix saddle-type clamps** allow the cables to be fixed securely and simply. C-rails and strain relief combs are fixed with the UMB connectors and do not have to be screwed separately.



- UMB connector
- Optional strain relief comb
- Connection with Linefix on C-rail
- The UMB connectors have mounts above and below for fixing a C-rail or strain relief comb.

Type CT 1555

Design 060*

Inside: Hinged, openable (on the right/left) and detachable covers

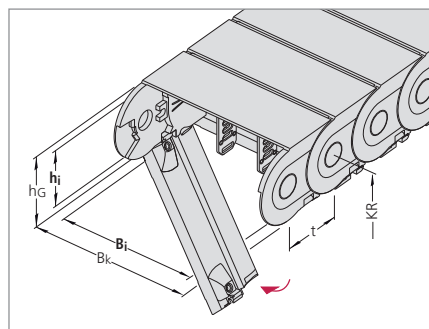

Design 080

Inside: Hinged, openable (on the right/left) and detachable covers

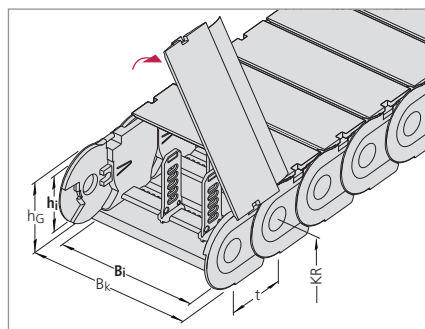

Inside heights
50

Inside widths
50 - 250

kabelschlepp.de

Dimensions and intrinsic chain weight

Type	h _i	h _G	Inside widths B _i									B _k	
			Intrinsic chain weight										
CT 1555	50	69	50*	75*	100*	115*	125	150*	175	200*	225*	250*	B _i + 21
			2.18	2.43	2.68	2.83	2.94	3.19	3.44	3.69	3.94	4.20	

* on request

Dimensions in mm/Weights in kg/m

Bend radius and pitch

Bend radii KR mm							Pitch t = 55.5 mm
100	125*	150	175*	200*	225*	250*	

* on request

Bend radius and pitch

for unsupported length L_f depending on the additional load

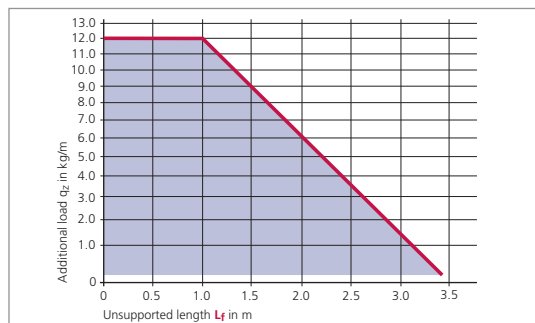

Unsupported length L_f

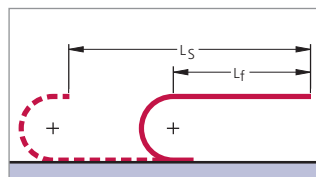

In the case of longer travel lengths, sag of the cable carriers is technically per-missible depending on the application. In a gliding arrangement, even longer travel lengths are possible (see page 295).

We are at your service to advise on these applications.

Example of ordering

Cable carrier					Divider system		Connection	
CT 1555	080	175	150	1110	TS 0	/	1	FU/MU
Type	Design	Inside width B _i in mm	Bend radius KR in mm	Chain length L _k in mm (without connection)	Divider system		Number of dividers n _T	Connection-Fixed point/Driver

Ordering divider systems:

Please state the designation of the divider system (TS 0, TS 1 ...) and the number of dividers. Possibly attach a sketch with the dimensions.

* On request – please contact us.

Fon: +49 2762 4003-0
Use our free project planning service.

Type CT 1555

Fixing the dividers

In the standard version, dividers or the complete divider system (dividers with height separation) can be moved in the cross section. (Mounting version A)

For applications with transverse accelerations and where the carrier is rotated through 90° the dividers can be fixed simply by turning them. This causes the arresting cams to engage in the locking profiles of the covers (Version B).

If the fixed installation version is desired, please state this on the order.

Inside heights



Inside widths



Version A (standard)

Movable divider

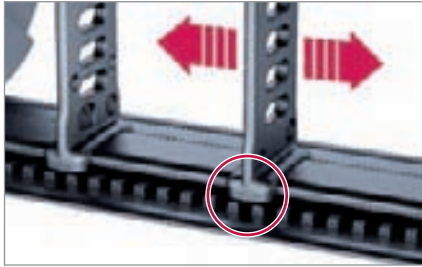

Version B

Divider fixed in 5 mm steps.

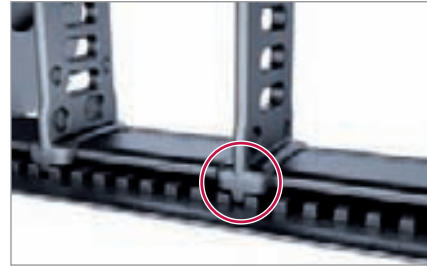

Divider system TS 0

Type	h _i mm	Version A			Version B			
		S _T mm	a _T min mm	a _x min mm	S _T mm	a _T min mm	a _x min mm	a _x section mm
CT 1555	50	3	5	10	3	7.5	10	5

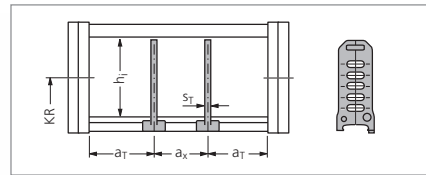

Divider system TS 1

with continuous height subdivision made of aluminium

Type	h _i mm	Version A			Version B			S _H mm	h ₁ mm	h ₂ mm	
		S _T mm	a _T min mm	a _x min mm	S _T mm	a _T min mm	a _x min mm				a _x section mm
CT 1555	50	3	5	10	3	7.5	10	5	4	14	28

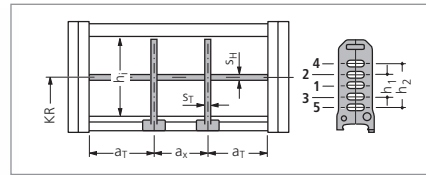

kabelschlepp.de

Fon: +49 2762 4003-0

OnlineEngineer.de
With Cable Concepts
 Cable Carrier Configurator

Type CT 1555

Universal mounting brackets

With plastic UMBs (Universal Mounting Brackets), you can easily connect the UNIFLEX from above, from below, or at head height

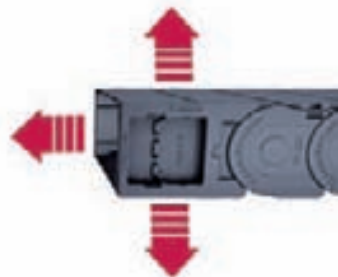

Inside heights

50

Inside widths

50
-
250

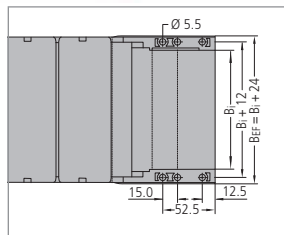
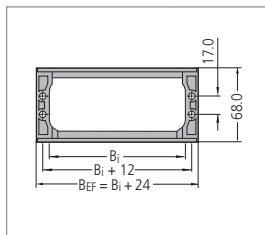
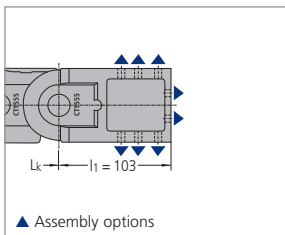

The dimensions of the fixed point and driver connections are identical.

When ordering please specify the connection type FU/MU (see ordering key on page 204).

Both-sided strain relief combs made of plastic

The cables can be fixed securely and simply using the **optional strain relief combs**.

The strain relief combs are installed between the UMBs, and do not need to be bolted on separately or mounted on a C-Rail.

Please state on the order whether strain relief combs are needed.



■ Universal mounting bracket with optional strain relief comb



■ Fixing in the UMB

Type	Bi mm	nz
CT 1555.50	50	3
CT 1555.75	75	5
CT 1555.100	100	7
CT 1555.125	125	9
CT 1555.150	150	11
CT 1555.175	175	13

nz = Number of teeth on one side of the comb

Strain relief comb made of aluminum on one side

The cables can be fixed securely and simply using the **optional strain relief combs**.

The strain relief combs are installed between the UMBs, and do not need to be bolted on separately or mounted on a C-Rail.

Please state on the order whether strain relief combs are needed.



■ Strain relief comb made of Aluminium

Use our free
project planning service.

206

kabelschlepp.de

Fon: +49 2762 4003-0

Type CT 1555

Strain relief devices

C-rails for LineFix bracket clamps, SZL strain reliefs and clamps

The optional C-rails are fixed by means of the universal mounting brackets and do not have to be screwed separately.

Please state in your order whether C-rails are needed.

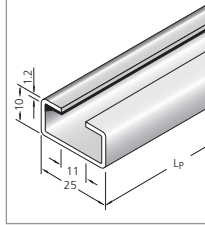
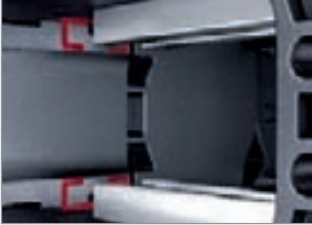

■ Universal mounting bracket with C-rail. The UMB connectors have mounts **above and below** for fixing a C-rail

■ Integratable C-rail 25 x 10 mm, slit width 11 mm, material steel, Item-No. 3931

Our LineFix strain reliefs are optimally suited for the C-rails. (LineFix bracket clamps and other strain relief devices – see Accessories chapter, from page 302 onwards).



■ C-rail with LineFix strain relief

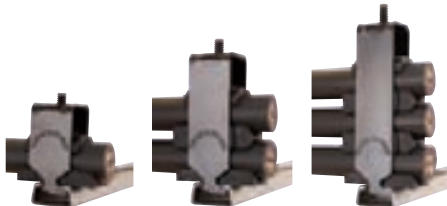

kabelschlepp.de

Font: +49 2762 4003-0

OnlineEngineer.de
 with Cable
 Center Configurator

Guide channels
 ▶ from page 295

Strain relief devices
 ▶ from page 302

Cables for cable carrier systems
 ▶ from page 344

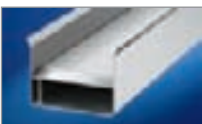

UNIFLEX

TUBES with fixed chain widths

Inside heights

19,5
-
44

Inside widths

15
-
175

- Solid plastic
- Easy to open
- Robust, double stroke system for long unsupported lengths
- Particularly high torsional rigidity
- End connectors with integrated strain relief
- Economically priced standard types
- TÜV design approved in accordance with 2PfG 1036/10.97

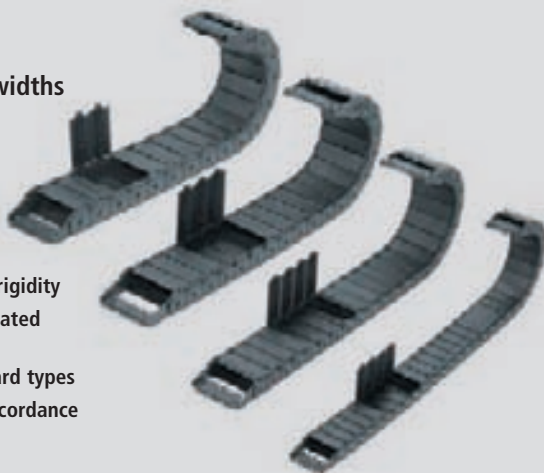

kabelschlepp.de

Design 050 – covered on one side

- Outside: Covered
- Inside: Hinged, openable (on the right/left) and detachable brackets

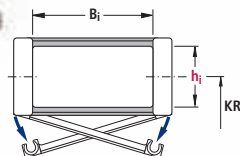

Fon: +49 2762 4003-0

Use our free project planning service.

Type	h_i	B_i	Maximum travel length in m	Dynamics of unsupported arrangement		Page
				Travel speed v_{max} in m/s	Travel acceleration a_{max} in m/s ²	
0345.050	20	15-65	80	10	50	102
0455.050	26	25-130	120	10	50	102
0555.050	38	50-150	125	9	45	102
0665.050	44	50-175	150	8	40	102

Dimensions in mm

Design 060 – covered on both sides

- Outside and inside: Covered
- Inside: Hinged, openable (on the right/left) and detachable cover

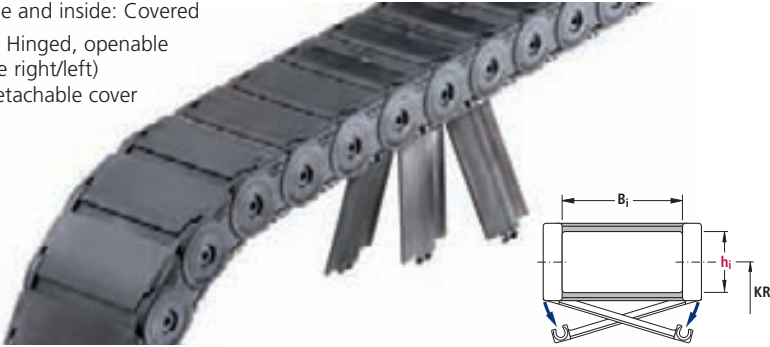

Type	h _i	B _i	Maximum travel length in m	Dynamics of unsupported arrangement		Page
				Travel speed v _{max} in m/s	Travel acceleration a _{max} in m/s ²	
0345.060	19.5	15-65	80	10	50	210
0455.060	25	25-130	120	10	50	210
0555.060	36	50-150	125	9	45	210
0665.060	42	50-175	150	8	40	210

Dimensions in mm

Inside heights



Inside widths



kabelschlepp.de

Design 080 – covered on both sides

- Outside and inside: Covered
- Outside: Detachable cover

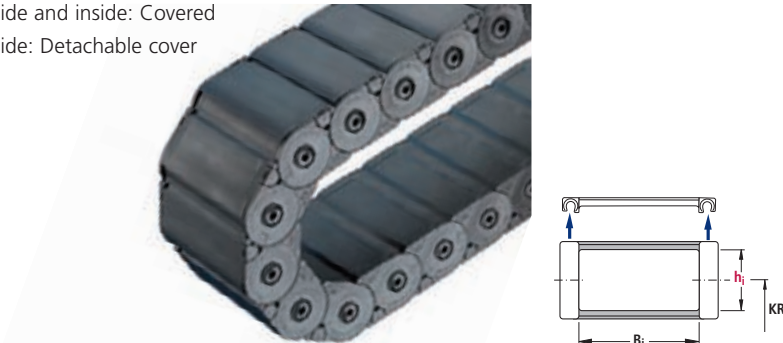

Type	h _i	B _i	Maximum travel length in m	Dynamics of unsupported arrangement		Page
				Travel speed v _{max} in m/s	Travel acceleration a _{max} in m/s ²	
0600.080	44	50-125	100	6	35	216

Dimensions in mm

Font: +49 2762 4003-0

OnlineEngineerde
the KABELSCHLEPP
 Cable Center Configurator

UNIFLEX – Types 0345, 0455, 0555 and 0665

Design 060 – cable carriers covered on both sides

Outside and inside: Covered

Inside: Hinged, openable (on the right/left) and detachable covers

Inside heights



Inside widths

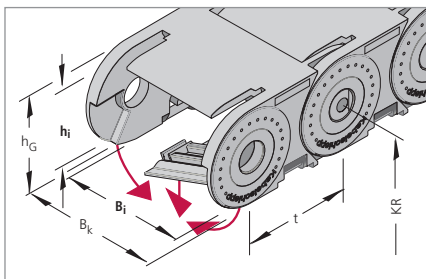

Dimensions and intrinsic chain weight

Type	h_i	h_G	Inside widths B_i					B_k	
			Intrinsic chain weight						
0345	19.5	28	15	20	25	38	50	65	$B_i + 13$
			0.48	0.52	0.56	0.65	0.74	0.85	
0455	25	36	25	38	58	78	103	130	$B_i + 18$
			0.92	1.01	1.16	1.31	1.51	1.72	
0555	36	50	50	75	100	125	150	–	$B_i + 22$
			1.72	1.95	2.17	2.39	2.61	–	
0665	42	60	50	75	100	125	150	175	$B_i + 27$
			2.36	2.69	3.00	3.32	3.64	3.95	

Dimensions in mm/Weights in kg/m

kabelschlepp.de

Fon: +49 2762 4003-0

Bend radius and pitch

Type	Bend radii KR mm					
0345	75	100	125	150	–	–
0455	95	125	150	180	200	225
0555	100	125	160	200	230	–
0665	120	140	200	250	300	–

Pitch t:

Type 0345: 34.5 mm

Type 0455: 45.5 mm

Type 0555: 55.5 mm

Type 0665: 66.5 mm

Use our free project planning service.

Example of ordering

Cable carrier

0555 - **060** - **125** - **160** - **1665**

Type Design Inside width B_i in mm Bend radius KR in mm Chain length L_k in mm (with-out connection)

Divider system

TS 0 / **3**

Divider system Number of dividers n_T

Connection

FU/MU

Connection Fixed point/Driver

Ordering divider systems:

Please state the designation of the divider system (TS 0, TS 1 ...) and the number of dividers. Possibly attach a sketch with the dimensions.

UNIFLEX – Types 0345, 0455, 0555 and 0665

Load diagram

for unsupported length L_f depending on the additional load

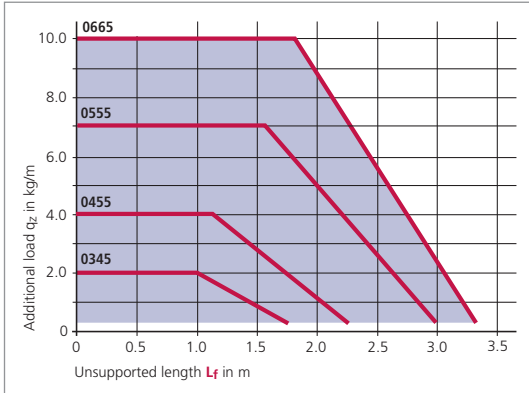

Unsupported length L_f

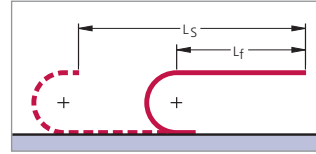

In the case of longer travel lengths, sag of the cable carriers is technically permissible depending on the application.

In a gliding arrangement, even longer travel lengths are possible (see page 295).

We are at your service to advise on these applications.

Inside heights



Inside widths



kabelschlepp.de

Divider system TS 0

Type	h_i mm	S_T mm	a_x mm	B_i mm	a_T min mm
0455	25	3	20	25	12.5
0455	25	3	20	38, 58, 78	19
0455	25	3	20	103	21.5
0455	25	3	20	130	25
0555	36	3	25	50 ... 150	25
0665	42	5	25	50 ... 175	25

The dividers are fixed at an interval of a_x .

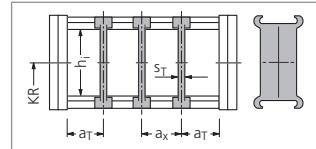

In the standard version, the divider systems are mounted on every second chain link.

For type 0665, the divider system TS 1 with a central height subdivision ($S_H = 4$ mm) is also available.

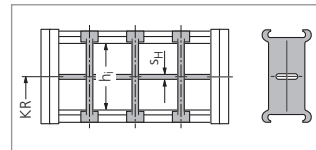

Font: +49 2762 4003-0

OnlineEngineer.de
KABELSCHLEPP
Cable Carrier Configurator

UNIFLEX – Types 0345, 0455, 0555 and 0665

Strain relief devices for plastic connectors

Inside heights



Inside widths



ZLK – A

Connecting elements with integrated, strain relief combs on both sides (ZLK – A)

ZLK – L

Connecting elements with screw-on type strain relief combs (ZLK – L)

The strain relief combs are generally supplied with the connecting elements. The combs are either clipped to the end connectors and bolted together with them, or screwed on at the desired intervals, behind the connecting boreholes, behind the connecting elements.

kabelschlepp.de



Connecting elements Type 0345

Connecting elements with integrated strain relief combs on both sides

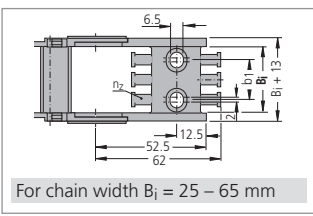
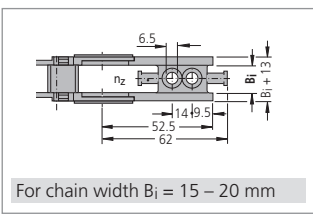
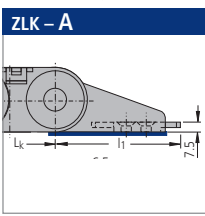

The dimensions of the fixed point and driver connections are identical.

Type	B_i	B_k	b_1	n_z
034515	15	28	–	1
034520	20	33	–	1
034525*	25	38	13	2
034538	38	51	24	3
034550	50	63	36	4
034565	65	78	51	5

* Type 034525 with 6.5 mm hole
Dimensions in mm (not an elongated hole)

Fon: +49 2762 4003-0

Use our free project planning service.

UNIFLEX – Types 0345, 0455, 0555 and 0665

Connecting elements Type 0455

Connecting elements with strain relief combs on both sides

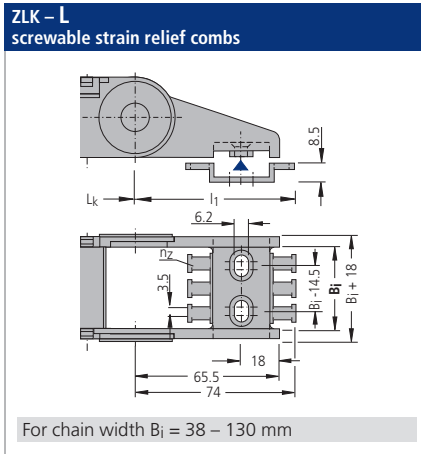
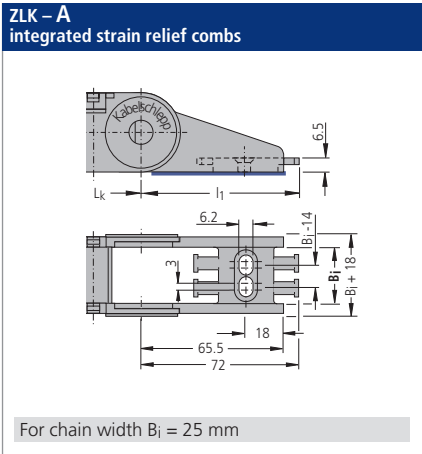

The dimensions of the fixed point and driver connections are identical.

Type	B_i	B_k	n_z
045525	25	43	2
045538	38	56	3
045558	58	76	4
045578	78	96	6
0455103	103	121	8
0455130	130	148	10

Dimensions in mm

Connecting elements Type 0555

Connecting elements with strain relief combs on both sides

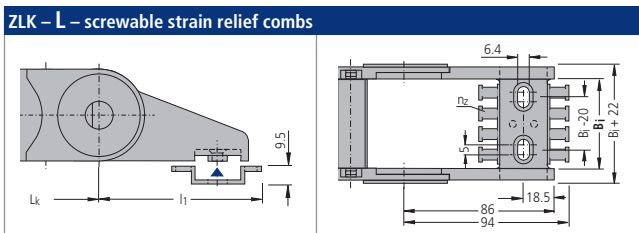

The dimensions of the fixed point and driver connections are identical.

Type	B_i	B_k	n_z
055550	50	72	4
055575	75	97	6
0555100	100	122	8
0555125	125	147	10
0555150	150	172	12

Dimensions in mm

Inside heights



Inside widths



kabelschlepp.de

Font:
+49 2762 4003-0

OnlineEngineer.de
KABELSCHLEPP
Cable Center Configurator

UNIFLEX – Types 0345, 0455, 0555 and 0665

Connecting elements Type 0665

Connecting elements with strain relief combs on both sides

Inside heights



Inside widths

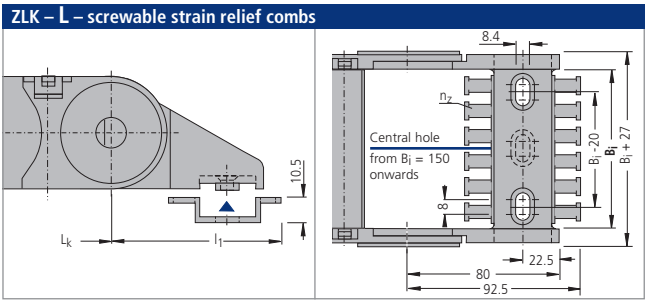

The dimensions of the fixed point and driver connections are identical.

Type	B _i	B _k	d _z
0665.50	50	77	4
0665.75	75	102	6
0665.100	100	127	8
0665.125	125	152	10
0665.150	150	177	12
0665.175	175	202	14
0665.200	200	227	16
0665.225	225	252	18
0665.250	250	277	20

Dimensions in mm

kabelschlepp.de

Fon: +49 2762 4003-0

Use our free project planning service.

Connection variants for design 060

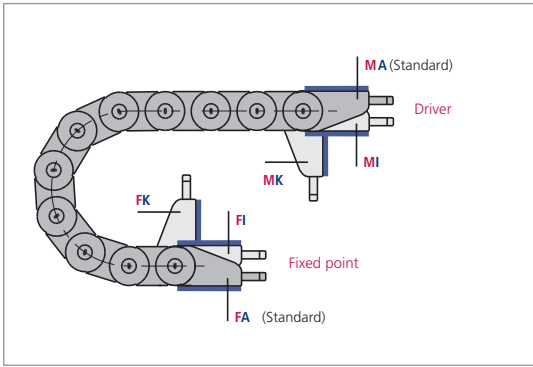

Connection point

- M** – Driver
- F** – Fixed point

Connection type

- A** – Threaded joint outside (standard)
- I** – Threaded joint inside
- H** – Threaded joint, rotated through 90° to the outside
- K** – Threaded joint, rotated through 90° to the inside

In the standard version, the connectors are mounted with the threaded joint outwards (**FA/MA**).
 When ordering please specify the desired connection type (see ordering key on page 334).
 The connection type can subsequently be altered simply by varying the connectors.

UNIFLEX – Types 0345, 0455, 0555 and 0665

UMB (Universal Mounting Brackets) made of aluminium

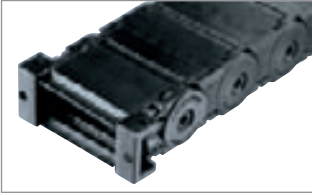

Universal connectors for connection above, below or at the front.

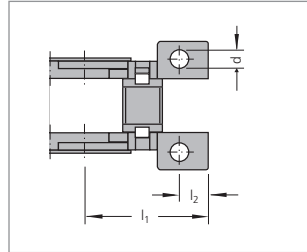
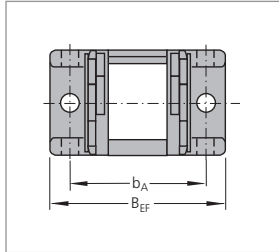
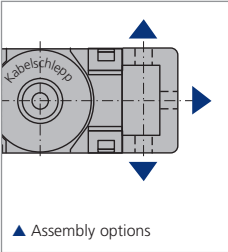

The dimensions of the fixed point and driver connections are identical.

When ordering please specify the connection type FU/MU (see ordering key on page 334).

Type	B_{EF}	b_A	l_1	l_2	d
0345	$B_i + 30$	$B_i + 20$	36	9	5.5
0455	$B_i + 30$	$B_i + 20$	47	10.5	5.5
0555	$B_i + 40$	$B_i + 28$	57	13.5	6.5
0665	$B_i + 44$	$B_i + 28$	68	14.5	8.5

Dimensions in mm

Inside heights



Inside widths



Guide channels
 ▶ from page 295

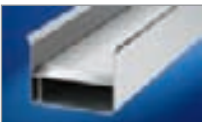

Strain relief devices
 ▶ from page 302



Cables for cable carrier systems
 ▶ from page 344



UNIFLEX – Type 0600 Tube, lightweight construction

Design 080 – cable carriers covered on both sides

Outside and inside: Covered
 Outside: Detachable cover

Innenhöhe



Inside widths

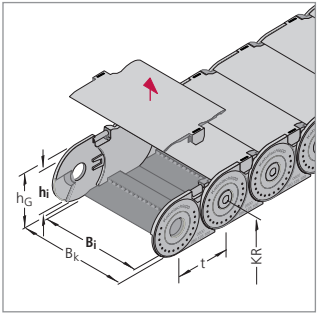

Cable carrier covered on both sides in a **lightweight design**. Can be opened on the outside for fast cable laying. Provides particularly good protection for the cables from all types of contamination, machining chips and moisture.

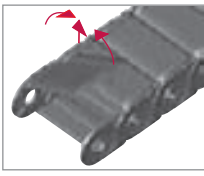

Also available with hinged cover – please contact us.

kabelschlepp.de

Dimensions and intrinsic chain weight

Type	h _i	h _G	Inside widths B _i				B _k
			50	75	100	125	
0600	44	61	1.60	1.88	2.15	2.42	B _i + 18
			Intrinsic chain weight				

Dimensions in mm/Weights in kg/m

Fon: +49 2762 4003-0

Bend radius and pitch

Bend radii KR mm				
100	125	150	175	200

Pitch t = 60.0 mm

Use our free project planning service.

Example of ordering

Cable carrier					Divider system		Connection
0600	080	125	175	1800	TS 0	3	FU/MU
Type	Design	Inside width B _i in mm	Bend radius KR in mm	Chain length L _k in mm (without connection)	Divider system	Number of dividers n _T	Connection Fixed point/Driver

Ordering divider systems:

Please state the designation of the divider system (TS 0, TS 1 ...) and the number of dividers. Possibly attach a sketch with the dimensions.

UNIFLEX – Type 0600 Tube, lightweight construction

Load diagram

for unsupported length L_f depending on the additional load

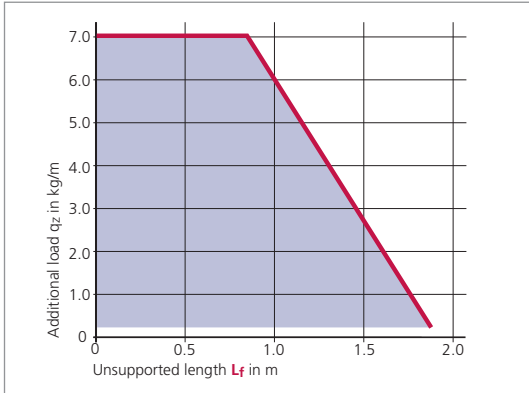

Unsupported length L_f

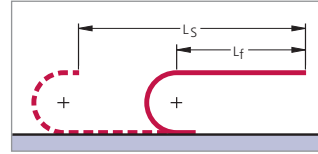

In the case of longer travel lengths, sag of the cable carriers is technically permissible depending on the application.

In a gliding arrangement, even longer travel lengths are possible (see page 295).

We are at your service to advise on these applications.

Innenhöhe

44

Inside widths

50

125

kabelschlepp.de

Divider system TS 0

Type	h_i mm	S_T mm
0600	44	3

In the standard version, the dividers can be moved in the cross section. The dividers can be fixed in 10 mm sections simply by re-attaching.

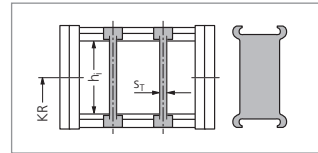

In the standard version, the divider systems are mounted on every second chain link.

Divider system TS 1 with continuous height subdivision

Type	h_i mm	S_T mm	S_H mm	h_1 mm	h_2 mm
0600	44	3	4	14	28

In the standard version, the dividers can be moved in the cross section. The dividers can be fixed in 10 mm sections simply by re-attaching.

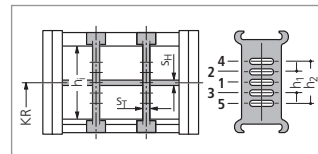

In the standard version, the divider systems are mounted on every second chain link.

Fon:

+49 2762 4003-0

UMB (Universal Mounting Brackets) made of aluminium

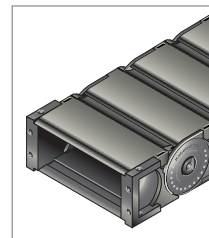
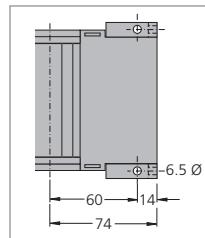
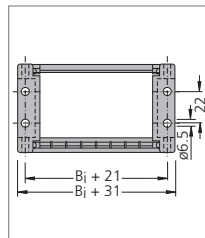
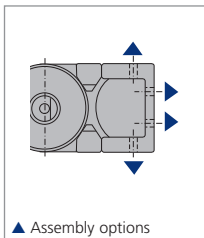

Subject to change.

The dimensions of the fixed point and driver connections are identical.

When ordering please specify the connection type FU/MU (see ordering key on page 334).

OnlineEngineer.de
KABELSCHLEPP
Cable Carrier Configurator

Inside heights



Inside widths



kabelschlepp.de

Types MASTER HT/LT

Quiet and weight-optimized cable carriers

- Extremely quiet due to internal noise damping system
- Favorable ratio of inner to outer dimensions
- Standard bend radii, application-specific intermediate radii on request
- Variable pretension for many different applications possible
- Can be opened quickly on the inside and outside for cable laying
- Transmission of forces (tensile and thrust forces) over a large area – optimized link design – "life extending 2 disc principle"
- Wide range of options for internal subdivision
- Closed and open UMBs
- Various strain relief systems optionally available



Type HT with plastic cover system (stay variant RDH)

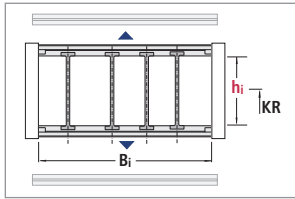

Fon: +49 2762 4003-0

Type	hi	Bi	Maximum travel length in m	Dynamics of unsupported arrangement		Page
				Travel speed v_{max} in m/s	Travel acceleration a_{max} in m/s ²	
HT 33	33	50 – 400	50	10	50	220
HT 46	46	50 – 400	70	8	40	220

Dimensions in mm

Carrier construction and cover system

The cover system of the MASTER HT series combines the stability of aluminium stays with the low weight of plastic covers.



Available in **1 mm width sections**.
Standard widths in 25 mm steps.
Opening options:
Outside/Inside: The covers can be opened and detached simply by a 15° rotation.

Type LT with plastic cover system (stay variant RDL)

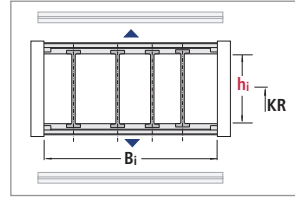

Inside heights

33
-
80

Inside widths

50
-
800

Type	h _i	B _i	Maximum travel length in m	Dynamics of unsupported arrangement		Page
				Travel speed v _{max} in m/s	Travel acceleration a _{max} in m/s ²	
LT 60	60	53 – 300	6.8*	6	30	220

* only unsupported

Dimensions in mm

Carrier construction and cover system

Available in 25 mm width sections.

Opening options:

Outside/Inside: Unscrewable cover



kabelschlepp.de

Type LT with aluminium cover system (stay variant RML)

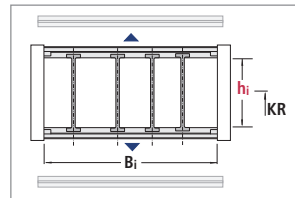

Font:

+49 2762 4003-0

Type	h _i	B _i	Maximum travel length in m	Dynamics of unsupported arrangement*		Page
				Travel speed v _{max} in m/s	Travel acceleration a _{max} in m/s ²	
LT 60	60	75 – 600	6.8**	6	30	220
LT 80	80	100 – 800	7.6**	5	25	220

* possible maximum values for small carrier widths; ** only unsupported

Dimensions in mm

Carrier construction and cover system

Available in 1 mm width sections.

Opening options:

Outside/Inside: Detachable clip-on covers

WIDTHSECTIONS



OnlineEngineer.de
KABELSCHLEPP
Cable Carrier Configurator

Types MASTER HT 33/46, LT 60/80

Dimensions and intrinsic chain weight

Inside heights



Inside widths



Plastic cover system (stay variant RDH)

Type	Stay variant	h _i	h _G	B _i min*	q _k min	B _i max*	q _k max	B _k
HT 33	RDH	33	51	50	1.63	400	5.72	B _i + 22
HT 46	RDH	46	64	50	2.17	400	5.73	B _i + 26

* Standard widths in 25 mm steps Dimensions in mm/Weights in kg/m

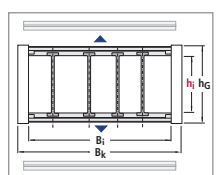

Plastic cover system (stay variant RDL)

Type	Stay variant	h _i	h _G	B _i min*	q _k min	B _i max	q _k max	B _k	Widths section
LT 60	RDL	60	88	75	3.21	300	6.07	B _i + 28	25

* B_i 53 also available Dimensions in mm/Weights in kg/m

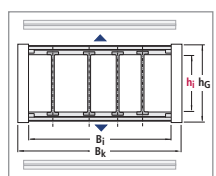

Aluminium cover system (stay variant RML)

Type	Stay variant	h _i	h _G	B _i min*	q _k min	B _i max*	q _k max	B _k
LT 60	RML	60	88	75	3.76	600	15.00	B _i + 28
LT 80	RML	80	110	100	5.10	800	19.71	B _i + 32

* Standard widths in 25 mm steps. Dimensions in mm/Weights in kg/m

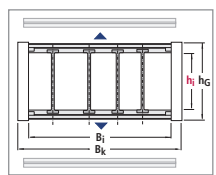

Bend radius and pitch

Type	Bend radii KR mm								
HT 33	100	125	150	175	200	220	250	300	-
HT 46	-	125	150	170	200	215	250	300	350
LT 60	150	200	250	300	350	400	500	-	-
LT 80	-	200	250	300	350	400	500	-	-

Pitch:
 HT 33: t = 56 mm
 HT 46: t = 67 mm
 LT 60: t = 91 mm
 LT 80: t = 111 mm

The listed values are standard bend radii. For special applications it is also possible, to set any desired intermediate radii at the production stage.

Please do get in touch with us, we would be happy to advise you.

kabelschlepp.de

Fon: +49 2762 4003-0

Use our free project planning service.

Guide channels
 ▶ from page 295



Strain relief devices
 ▶ from page 302



Cables for cable carrier systems
 ▶ from page 344



Types MASTER HT 33/46, LT 60/80

Load diagram

for unsupported length L_f depending on the additional load*

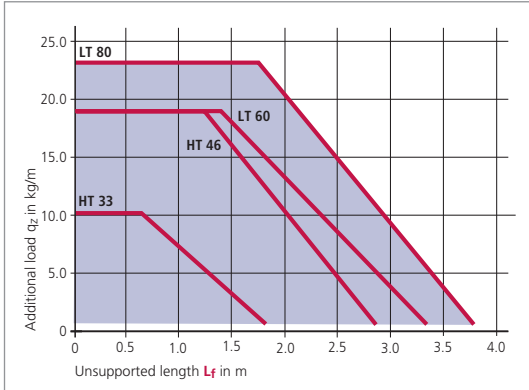

Unsupported length L_f

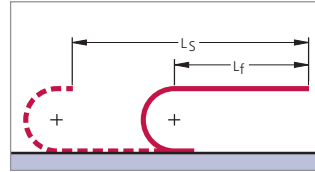

In the case of longer travel lengths, sag of the cable carriers is technically permissible depending on the application.

In a gliding arrangement, even longer travel lengths are possible (see page 295).

We are at your service to advise on these applications.

Determining the length of the cable carrier see page 41.

* Load diagram for intrinsic chain weight q_k of 4.0 kg/m (L 60) and 4.9 kg/m (L 80).

If the chain intrinsic weight exceeds these values, the permissible additional load is reduced by the difference.

Inside heights

33
-
80

Inside widths

50
-
800

kabelschlepp.de

Fon: +49 2762 4003-0

Example of ordering

Cable carrier					Divider system		Connection
LT 80	300	RML	300	3330	TS 0	3	FU/MU
Type	Inside width B_i in mm	Stay variant	Bend radius KR in mm	Chain length L_k in mm (without connection)	Divider system	Number of dividers n_T	Connection* Fixed point/Driver

Ordering divider systems:

Please state the designation of the divider system (TS 0, TS 1 ...) and the number of dividers. Possibly attach a sketch with the dimensions.

* If the standard connector is not required, please state this on the order.

Types MASTER HT 33/46, LT 60/80

Divider system TS 0

Inside heights



Inside widths



Type	h _i mm	S _T mm	a _T min mm	a _x min mm
HT 33	33	3	7	13
HT 46	46	3	7	13
LT 60	60	4	9	16
LT 80	80	4	9	16

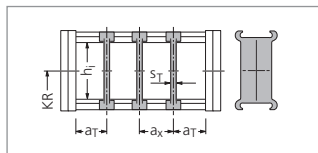

The dividers can be moved in the cross section. Dimensions in mm

In the standard version, the divider systems are mounted on every second chain link.

kabelschlepp.de

Divider system TS 1 with continuous height subdivision made of aluminium

Type	h _i mm	S _T mm	a _T min mm	a _x min mm	S _H mm	h ₁ mm	h ₂ mm	h ₃ mm	h ₄ mm
HT 33	33	3	7	13	4	18	-	-	-
HT 46	46	3	7	13	4	20	-	-	-
LT 60	60	4	9	16	4	15	30	45	-
LT 80	80	4	9	16	4	15	30	45	60

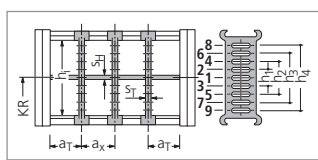

The dividers can be moved in the cross section. Dimensions in mm

In the standard version, the divider systems are mounted on every second chain link.

Fon: +49 2762 4003-0

Divider system TS 3 with section subdivision, partitions made of plastic

Type	h _i mm	S _T mm	a _T min mm	a _x min mm	S _H mm	h ₁ mm	h ₂ mm	h ₃ mm	h ₄ mm
HT 33	33	8	6	16*	4	14	-	-	-
HT 46	46	8	6	16*	4	14	28	-	-
LT 60	60	8	6	16*	4	14	28	-	-
LT 80	80	8	6	16*	4	14	28	42	56

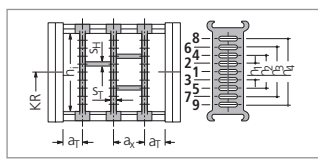

* When using plastic partitions Dimensions in mm

The dividers are fixed by the partitions, the complete divider system is movable.

In the standard version, the divider systems are mounted on every second chain link.

Use our free project planning service.

Dimensions of the plastic partitions for TS 3

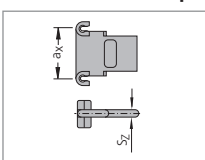

S _Z	a _x (center-to-center dividers)									
	16	18	23	28	32	33	38	43	48	58
4	64	68	78	80	88	96	112	128	144	160
	176	192	208	-	-	-	-	-	-	-

Dimensions in mm

Aluminium partitions in 1 mm width sections are also available. When using partitions with a_x > 112 mm there should be an additional central support with a twin divider.

Twin dividers are designed for subsequent fitting in the partition system.

Types MASTER HT 33/46, LT 60/80

Glide shoes – the economical solution for gliding applications (HT 33/46)

Replaceable glide shoes made of plastic

To extend the life of cable carriers in gliding operations KABELSCHLEPP supplies detachable, exchangeable glide shoes. Replaceable glide shoes are a very economical solution. When wear occurs only the glide shoes are replaced, and not the complete cable carrier.

Glide shoes for the H Series are made of a highly wear-resistant special material.



Inside heights



Inside widths



Chain height with glide shoes:

HT 33: $h_G' = h_G + 3.2 = 54.2$
 HT 46: $h_G' = h_G + 3.2 = 67.2$

Dimensions in mm

Minimum bend radii when using glide shoes:

HT 33: $KR_{min} = 100$ mm
 HT 46: $KR_{min} = 100$ mm

! By means of a positive snap connection, the glide shoes sit firmly on the chain link.

Minimized hinge wear owing to the "life extending 2 disc principle"

In the MASTER Series, the push and pull forces are transmitted via the optimum link design for this purpose.

As a result link wear is reduced to a minimum and the life of the cable carrier is considerably lengthened.

The internal stopper and pre-tensioning dampers have a noise-muffling effect. This makes the chain particularly quiet.

Should your application require it, the pre-tensioning (in deviation from the standard pre-tensioning) can be adjusted at the time of production. We can produce a cable carrier with a pre-tension which is exactly suited to the load values of your application.

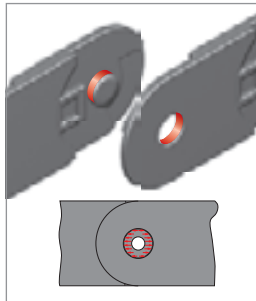

■ Force transmission with a pin-hole joint

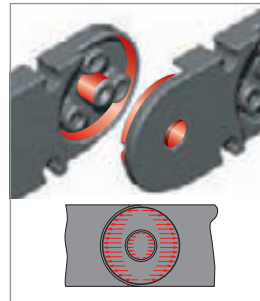

■ Force transmission with the "life extending 2 disc principle"

kabelschlepp.de

Font: +49 2762 4003-0

OnlineEngineer.de
 with CONCEPT Cable Carrier Configurator

Guide channels
 ▶ from page 295

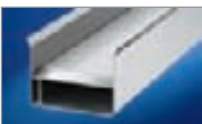

Strain relief devices
 ▶ from page 302



Cables for cable carrier systems
 ▶ from page 344



Types MASTER HT 33/46, LT 60/80

UMB (Universal Mounting Brackets) made of plastic

Various universal mounting brackets made of plastic provide a suitable connection for any assembly situation. Each type can be screwed from above, below or as a flange.

Inside heights



Inside widths

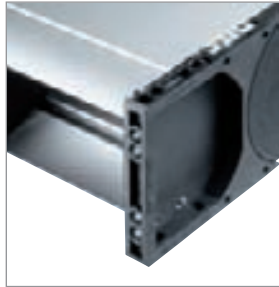

kabelschlepp.de

Connection dimensions Type HT 33

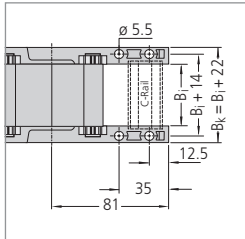
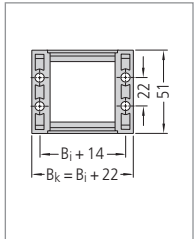
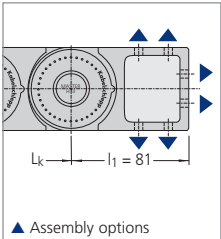

The dimensions of the fixed point and driver connections are identical.

Optional C-rails and strain relief elements for cables can be found on the following pages.

When ordering please specify the connection type FU/MU (see ordering key on page 337).

Fon: +49 2762 4003-0

Connection dimensions Type HT 46

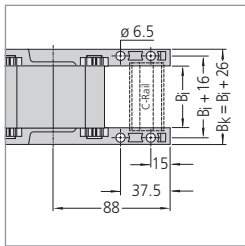
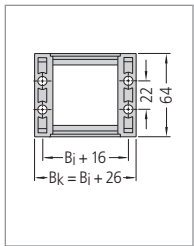
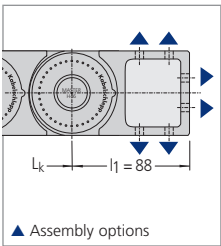

The dimensions of the fixed point and driver connections are identical.

Optional C-rails and strain relief elements for cables can be found on the following pages.

When ordering please specify the connection type FU/MU (see ordering key on page 337).

Use our free project planning service.

Types MASTER HT 33/46, LT 60/80

Connection dimensions Type LT 60

Standard connector and short, open connector

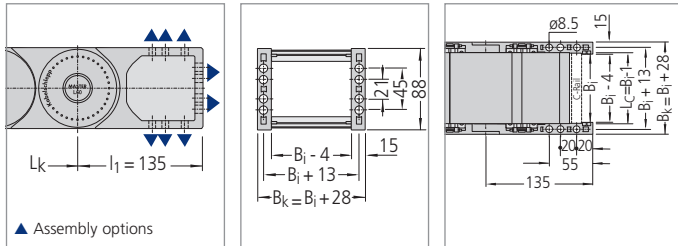

Inside heights

33
-
80

Inside widths

50
-
800

The dimensions of the fixed point and driver connections are identical.

Optional C-rails and strain relief elements for cables can be found on the following pages.

When ordering please specify the connection type FU/MU (see ordering key on page 337).

Connection dimensions Type LT 80

Standard connector and short, open connector

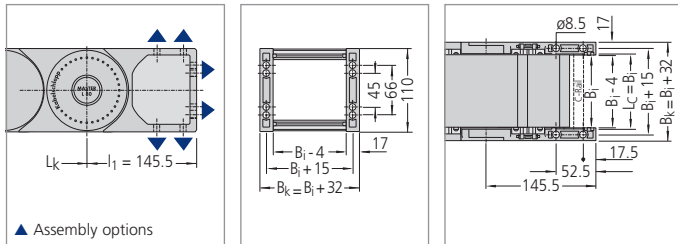

The dimensions of the fixed point and driver connections are identical.

Optional C-rails and strain relief elements for cables can be found on the following pages.

When ordering please specify the connection type FU/MU (see ordering key on page 337).

kabelschlepp.de

Font:
+49 2762 4003-0

OnlineEngineer.de
with CableCarrier
Cable Carrier Configurator

Guide channels
➤ from page 295



Strain relief devices
➤ from page 302



Cables for cable carrier systems
➤ from page 344



Types MASTER HT 33/46, LT 60/80

Strain relief devices

Strain relief combs made of plastic on both sides for standard carrier widths (MASTER HT)

The cables can be fixed securely and simply using the **optional strain relief combs**.

The strain relief combs are installed between the UMBs, and do not need to be bolted on separately or mounted on a C-Rail.

Please state on the order whether strain relief combs are needed.

Inside heights



Inside widths



■ Universal mounting bracket with strain relief comb



■ Both-sided strain relief comb

kabelschlepp.de



■ Fixing in the UMB.

Type	B _i mm	n _z
HT 33/46	50	3
HT 33/46	70	5
HT 33/46	75	5
HT 33/46	95	7
HT 33/46	100	7
HT 33/46	115	8
HT 33/46	120	9
HT 33/46	125	9
HT 33/46	145	11
HT 33/46	150	11
HT 33/46	170	13
HT 33/46	175	13
HT 33/46	195	15
HT 33/46	200	15
HT 33/46	225*	17
HT 33/46	250*	19

n_z = Number of teeth on one side of the comb

* on request

Fon: +49 2762 4003-0

Strain relief comb made of aluminium on one side for individual carrier widths (MASTER HT)

The cables can be fixed securely and simply using the **optional strain relief combs**.

The strain relief combs are installed between the universal mounting brackets, and do not need to be bolted on separately or mounted on a C-Rail.

Please state on the order whether strain relief combs are needed.



■ Strain relief comb made of aluminium

Use our free project planning service.

Types MASTER HT 33/46, LT 60/80

Strain relief devices

C-rails for LineFix bracket clamps, SZL strain reliefs and clamps

The optional C-rails are fixed by means of the universal mounting brackets and do not have to be screwed separately.

Please state in your order whether C-rails are needed.



■ Universal mounting bracket with C-rail

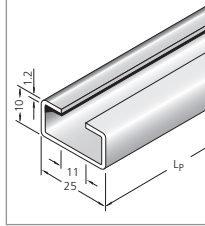

■ **MASTER HT:**
Integratable C-rail
25 x 10 mm,
slit width 11 mm,
material steel,
Item-No. 3931

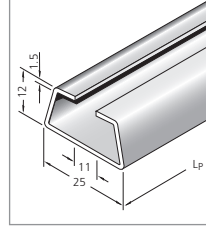

■ **MASTER LT:**
Integratable C-rail
25 x 12 mm,
slit width 11 mm,
material steel,
Item-No. 3934

Inside heights



Inside widths



kabelschlepp.de

Our LineFix strain reliefs are optimally suited for the C-rails. (LineFix bracket clamps and other strain relief devices – see Accessories chapter, from page 302 onwards).



■ C-rail with LineFix strain relief

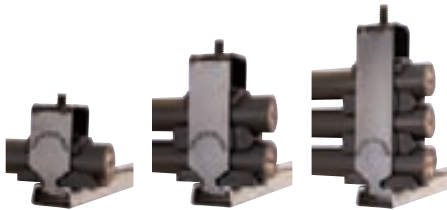

Font:
+49 2762 4003-0

OnlineEngineer.de
Kabelschlepp
Cable Carrier Configurator

MT Series

Multivariable cable carrier with plastic or aluminium cover system

Inside heights

26
-
87

Inside widths

24
-
800

kabelschlepp.de

- Aluminium cover system in 1 mm width sections, plastic cover system in 8 or 16 mm width sections available
- Can be opened quickly on the inside and the outside for cable laying
- Extremely robust due to stable plate construction
- Enclosed stroke system not sensitive to dirt/contamination
- Transmission of forces (tensile and shearing forces) over a large surface area via the optimum link design – according to the “life extending 2 disc principle”
- Standard universal mounting brackets (UMBs)
- Many separation options for the cables
- Highly wear-resistant, replaceable glide shoes available – resulting in minimal wear at high speeds, sliding in the guide channel
- Optionally available with different strain relief systems
- TÜV design approved in accordance with 2PFG 1036/10.97

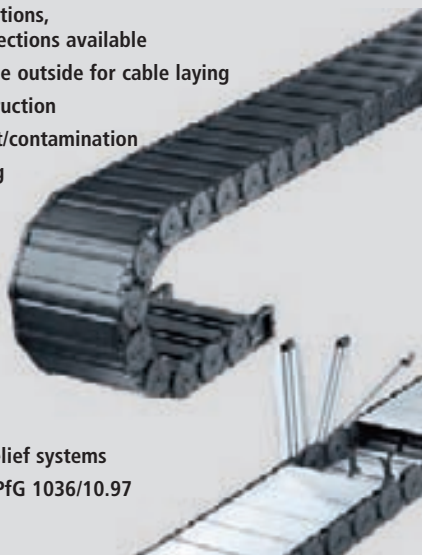

Type MT with plastic cover system (stay variant RDD)

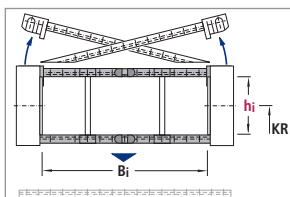

Fon: +49 2762 4003-0

Type	h_i	B_i	Maximum travel length in m	Dynamics of unsupported arrangement		Page
				Travel speed v_{max} in m/s	Travel acceleration a_{max} in m/s ²	
MT 0475	26	24-280	100	10	40	230
MT 0650	38.5	50-258	170	8	35	230
MT 0950	54.5	77-349	230	6	25	230
MT 1250	68.5	103-359	270	5	20	230

Dimensions in mm

Carrier construction and cover system

MT 0475, 0650:

Available in 8 mm width sections.

MT 0950, 1250:

Available in 16 mm width sections.

Opening options

Outside: Simply by levering the cover open (on the right or left). Cover can also be removed

Inside: Simply by turning the cover

MT 0475 is available with a cover that can be levered open to the inside. Please specify when ordering.



Use our free project planning service.

Type MT with aluminium cover system (stay variant RMD)

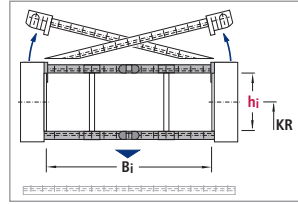

Inside heights

26
-
87

Inside widths

24
-
800

Type	h _i	B _i	Maximum travel length in m	Dynamics of unsupported arrangement		Page
				Travel speed v _{max} in m/s	Travel acceleration a _{max} in m/s ²	
MT 0475	26	24-180	100	10	40	230
MT 0650	38.5	100-500	170	8	35	230
MT 0950	54.5	100-600	230	6	25	230
MT 1250	68.5	150-800	270	5	20	230
MT 1300	87	100-800	300	5	20	230

Dimensions in mm

Carrier construction and cover system

WIDTH SECTIONS



Available in 1 mm width sections.

Opening options (MT 0475, 0650, 0950, 1250)

Outside: Simply by levering the cover open (on the right or left). Cover can also be removed
Inside: Simply by turning the cover

MT 0475 is available with a cover that can be levered open to the inside. Please specify when ordering.

Opening options (MT 1300)

Inside/Outside: bolted cover for maximum stability

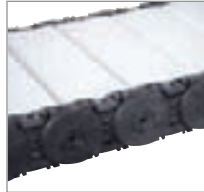

■ Cover openable (MT 0475, 0650, 0950, 1250)

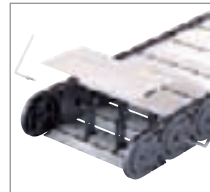

■ Cover bolted (MT 1300)

Guide channels
► from page 295

Strain relief devices
► from page 302

Cables for cable carrier systems
► from page 344

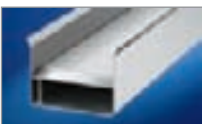

Types MT 0475, 0650, 0950, 1250 and 1300

Dimensions and intrinsic chain weight

Plastic cover systems (stay variant RDD)

Type	Stay variant	h _i	h _g	B _i min	q _k min	B _i max	q _k max	B _k	Width section
MT 0475	RDD	26	39	24	0.9	280	4.4	B _i + 17	8
MT 0650	RDD	38.5	57	50	2.4	258	3.7	B _i + 34	8
MT 0950	RDD	54.5	80	77	4.3	349	7.7	B _i + 39	16
MT 1250	RDD	68.5	96	103	5.7	359	8.9	B _i + 45	16

Dimensions in mm/Weights in kg/m

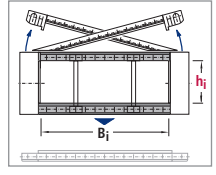

Aluminium cover systems (stay variant RMD)

Type	Stay variant	h _i	h _g	B _i min	q _k min	B _i max	q _k max	B _k
MT 0475	RMD	26	39	24	0.9	180	4.5	B _i + 17
MT 0650	RMD	38.5	57	100	3.3	500	9.7	B _i + 34
MT 0950	RMD	54.5	80	100	5.5	600	16.2	B _i + 39
MT 1250	RMD	68.5	96	150	9.0	800	26.0	B _i + 45
MT 1300	RMD	87	120	100	8.8	800	27.4	B _i + 50

Dimensions in mm/Weights in kg/m

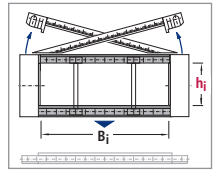

kabelschlepp.de

Bend radius and pitch

Type	Bend radii KR mm								
MT 0475	75	100	130	160	200	250	300	-	-
MT 0650	95*	115	145	175	220	260	275	300	350
MT 0950	140*	170*	200	260	290	320	380	-	-
MT 1250	220*	260	300	340	380	500	-	-	-
MT 1300	240	280	320	360	400	500	-	-	-

* not for aluminium cover system RMD

Pitch:

- MT 0475: t = 47.5 mm
- MT 0650: t = 65 mm
- MT 0950: t = 95 mm
- MT 1250: t = 125 mm
- MT 1300: t = 130 mm

Load diagram

for unsupported length L_f depending on the additional load

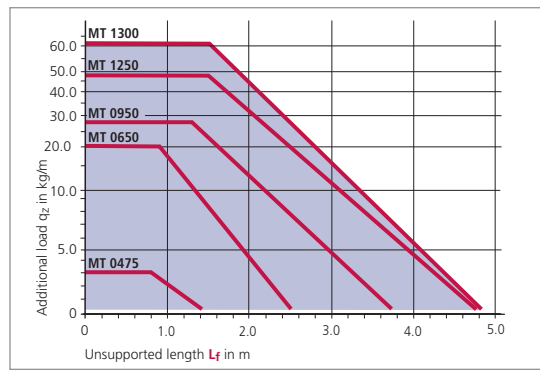

Unsupported length L_f

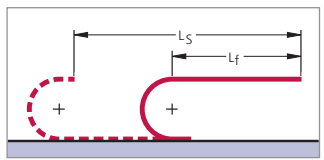

In the case of longer travel lengths, sag of the cable carriers is technically permissible depending on the application. In a gliding arrangement, even longer travel lengths are possible (see page 295). We are at your service to advise on these applications.

Fon: +49 2762 4003-0

Use our free project planning service.

Example of ordering

Cable carrier	Divider system	Connection
MT 0950 - 450 - RMD - 290 - 2850	TS 0 / 4	FU/MU
Type	Divider system	Connection
Inside width B _i in mm	Number of dividers n _T	Fixed point/Driver
Stay variant		
Bend radius KR in mm		
Chain length L _k in mm (without connection)		

Ordering divider systems:

Please state the designation of the divider system (TS 0, TS 1 ...) and the number of dividers. Possibly attach a sketch with the dimensions.

Types MT 0475, 0650, 0950, 1250 and 1300

Divider system TS 0

Type	Stay variant	h _i mm	S _T mm	a _T min mm	a _x min mm	a _x section mm
MT 0475	RDD	26	2.8	12	8	8
MT 0475	RMD	26	2.8	6	8	—
MT 0650	RDD	38.5	4.2	13	16	8
MT 0650	RMD	38.5	3	16	13	—
MT 0950	RDD	54.5	6	22.5	16	16
MT 0950	RMD	54.5	4	7	14	—
MT 1250	RDD	68.5	8	19.5	16	16
MT 1250	RMD	68.5	5	10	20	—
MT 1300	RMD	87	5	7.5	15	5

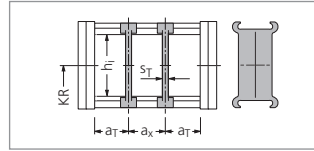

In the standard version, the divider systems are mounted on every second chain link.

Inside heights



Inside widths



With plastic cover systems (RDD), the dividers are fixed in the cross-section (at intervals of a_x-section). With aluminium cover systems (RMD), the dividers can be moved.

Divider system TS 1 with continuous height subdivision made of aluminium

Type	Stay variant	h _i mm	S _T mm	a _T min mm	a _x min mm	a _x section mm	S _H mm	h ₁ mm	h ₂ mm	h ₃ mm	h ₄ mm
MT 0475	RDD	26	2.8	12	8	8	2.4	15	—	—	—
MT 0475	RMD	26	2.8	6	8	—	2.4	15	—	—	—
MT 0650	RDD	38.5	4.2	13	16	8	4	10	22	—	—
MT 0650	RMD	38.5	3	16	13	—	4	—	—	—	—
MT 0950	RDD	54.5	6	22.5	16	16	4	22	—	—	—
MT 1250	RDD	68.5	8	19.5	32	16	4	32	—	—	—
MT 1300	RMD	87	5	7.5	15	—	4	14	28	42	56

With plastic cover systems (RDD), the dividers are fixed in the cross-section (at intervals of a_x-section). With aluminium cover systems (RMD), the dividers can be moved.

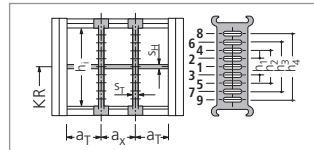

In the standard version, the divider systems are mounted on every second chain link.

Divider system TS 2 with grid subdivision made of aluminium (1 mm grid)

Type	Stay variant	h _i mm	S _T mm	a _T min mm	a _x min mm	a _x section mm	S _H mm	h ₁ mm
MT 0475	RDD	26	2.8	12	8	8	2.4	15
MT 0650	RDD	38.5	4.2	13	16	8	4	10

With plastic cover systems (RDD), the dividers are fixed in the cross-section (at intervals of a_x-section).

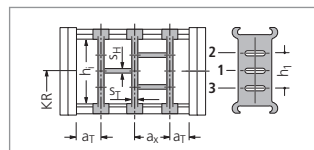

In the standard version, the divider systems are mounted on every second chain link.

Types MT 0475, 0650, 0950, 1250 and 1300

Divider system TS 3 with section subdivision, partitions made of plastic

Inside heights



Inside widths



Type	Stay variant	h _i mm	S _T mm	a _T min mm	a _x min mm	S _H mm	h ₁ mm	h ₂ mm	h ₃ mm	h ₄ mm
MT 0950	RDD	54.5	8	6.5	16*	4	14	28	42	—
MT 1250	RDD	68.5	8	4	16*	4	14	28	42	56
MT 1300	RMD	87	8	7.5	16*	4	14	28	42	56

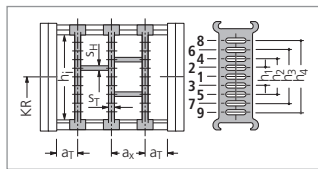

* When using plastic partitions

With plastic cover systems (RDD), the dividers are fixed in the cross-section. In the standard version, the divider systems are mounted on every second chain link.

Dimensions of plastic partitions for TS 3

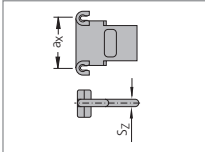

S _Z	a _x (center-to-center distance, dividers)									
4	16	18*	23*	28*	32	33*	38*	43*	48	58*
	64	68*	78*	80	88*	96	112	128	144	160
	176	192	208	—	—	—	—	—	—	—

* only MT 1300

Dimensions in mm

Aluminium partitions in 1 mm width sections are also available.

When using partitions with a_x > 112 mm there should be an additional central support with a twin divider (S_T = 4 mm).

Twin dividers are designed for subsequent fitting in the partition system.

kabelschlepp.de

Connectors of plastic/steel – Type MT 0475

End connector of steel plate

Screwable strain relief of aluminium on inquiry.

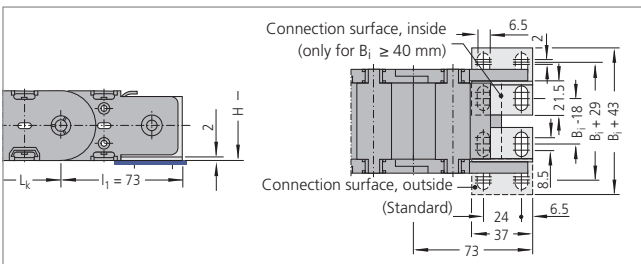

The dimensions of the fixed point and driver connections are identical.

Connection variants – Type MT 0475

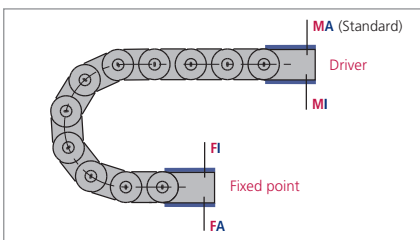

Connection point

- M – Driver
- F – Fixed point

Connection type

- A – Threaded joint outside (standard)
- I – Threaded joint inside

In the standard version, the connectors are mounted with the threaded joint outwards (FA/MA).

When ordering please specify the desired connection type (see ordering key on page 337).

The connection type can subsequently be altered.

Glide shoes and "life extending 2 disc principle" – see page 223.

Fon: +49 2762 4003-0

Use our free project planning service.

Types MT 0475, 0650, 0950, 1250 and 1300

UMB-connectors of aluminium – Type MT 0650

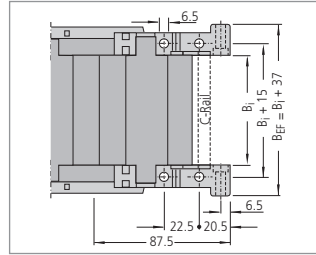
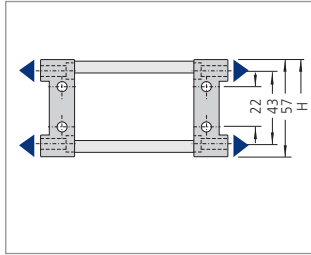
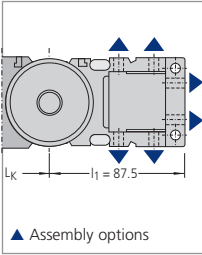

Inside heights

26
-
87

Inside widths

24
-
800

The dimensions of the fixed point and driver connections are identical.

End connectors of steel plate available on inquiry.

Optional C-rails and strain relief elements for cables can be found on the following pages.

When ordering please specify the connection type FU/MU (see ordering key on page 337).



UMB-connectors of aluminium – Types MT 0950, 1250

UMB-connectors of plastic – Type MT 1300

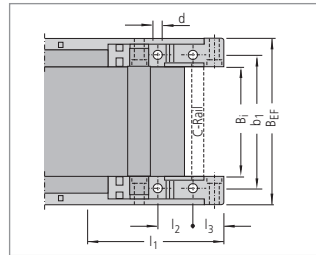
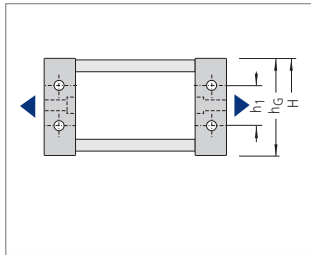
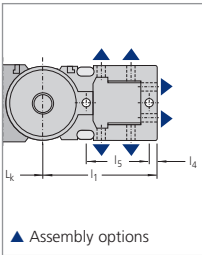

The dimensions of the fixed point and driver connections are identical.

End connectors of steel plate available on inquiry.

Optional C-rails and strain relief elements for cables can be found on the following pages.

When ordering please specify the connection type FU/MU (see ordering key on page 337).

Type	B _{EF}	b ₁	d	l ₁	l ₂	l ₃	l ₄	l ₅	h ₁	h _G
MT 0950	B _i + 44	B _i + 24.5	8,5	136	35	24.5	8.5	80	45	80
MT 1250	B _i + 51	B _i + 28	11	168	35	31	10.5	94.5	45	96
MT 1300	B _i + 50	B _i + 29	11	158	35	20	-	-	66	120

B_{EF} = Chain width over connector

Dimensions in mm

Types MT 0475, 0650, 0950, 1250 and 1300

Strain relief devices

Both-sided strain relief combs made of plastic (MT 0650)

The cables can be fixed securely and simply using the **optional strain relief combs**.

The strain relief combs are installed between the UMBs, and do not need to be bolted on separately or mounted on a C-Rail.

Please state on the order whether strain relief combs are needed.

Inside heights



Inside widths



■ Universal mounting bracket with strain relief comb



■ Both-sided strain relief comb

kabelschlepp.de



■ Fixing in the UMB.

Type	B _i mm	n _z
MT 0650	50	3
MT 0650	75	5
MT 0650	95	7
MT 0650	100	7
MT 0650	115	8
MT 0650	120	9
MT 0650	125	9
MT 0650	145	11
MT 0650	150	11
MT 0650	170	13
MT 0650	175	13
MT 0650	195	15
MT 0650	200	15
MT 0650	225*	17
MT 0650	250*	19

n_z = Number of teeth on one side of the comb

* on request

Fon:
+49 2762 4003-0

Use our free
project planning service.

Types MT 0475, 0650, 0950, 1250 and 1300

Strain relief devices

C-rails for LineFix bracket clamps, SZL strain reliefs and clamps

The optional C-rails are fixed by means of the universal mounting brackets and do not have to be screwed separately.

Please state in your order whether C-rails are needed.

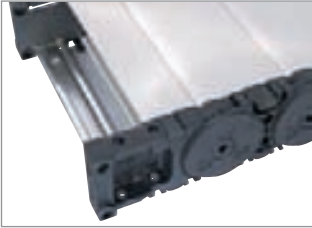

■ Universal mounting bracket with C-rail

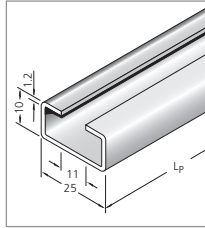

■ **MT 0650:**
Integratable C-rail
25 x 10 mm,
slit width 11 mm,
material steel,
Item-No. 3931

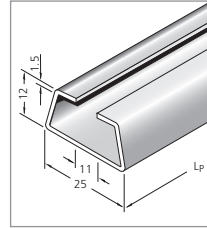

■ **MT 1300:**
Integratable C-rail
25 x 12 mm,
slit width 11 mm,
material steel,
Item-No. 3934

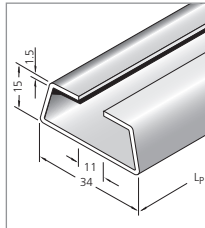

■ **MT 0950, 1250 and 1300:**
Integratable C-rail
34 x 15 mm,
slit width 11 mm,
material steel,
Item-No. 3935

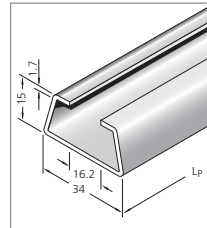

■ **MT 0950, 1250 and 1300:**
Integratable C-rail
34 x 15 mm,
slit width 16 – 17 mm,
material aluminium,
Item-No. 3926,
material steel,
Item-No. 3932

Inside heights



Inside widths



kabelschlepp.de

Font:
+49 2762 4003-0

Our LineFix strain reliefs are optimally suited for the C-rails. (LineFix bracket clamps and other strain relief devices – see Accessories chapter, from page 302 onwards).



■ C-rail with LineFix strain relief

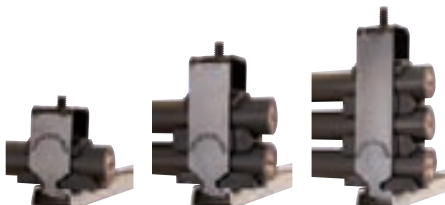

Types MT 0475, 0650, 0950, 1250 and 1300

Fixing the dividers in 5 mm steps – Type MT 1300

In the standard version, dividers or the complete divider system (dividers with height separation) can be moved in the cross section.

Fixing profiles can be used to fix the dividers or complete divider systems.

Also best suited for applications where the carrier is rotated through 90° with extreme transverse accelerations (fixable dividers for stay variant RMD).

If the fixed installation version is required, please state this when placing your order.

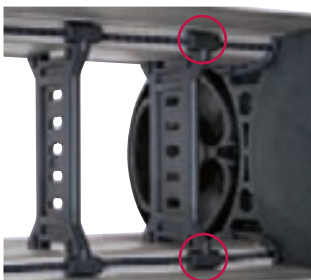

■ Secure seating of the dividers due to fixing on both sides.



■ The fixing profiles are simply pushed into the cover (RMD).

Inside heights

26
-
87

Inside widths

24
-
800

kabelschlepp.de

Fon: +49 2762 4003-0

Gliding elements – the economical solution for gliding applications

Replaceable glide shoes made of plastic

To extend the life of cable carriers in gliding operations KABELSCHLEPP supplies detachable, exchangeable glide shoes.

Replaceable glide shoes are a very economical solution. When wear occurs only the glide shoes are replaced, and not the complete cable carrier.

For travel speeds > 2.5 m/s and large additional loads, a highly wear-resistant special material is used.

For types MT 0950 and MT 1250 **OFFROAD glide shoes** with 80 % greater wear volumes are also available. We recommend their use in extreme environmental conditions (with particularly abrasive materials such as e. g. sand, dust, corundum).



! By means of a positive snap connection, the glide shoes sit firmly on the chain link.

Chain height with glide shoes:

MT 0475:	$h_{G'} = h_G + 2.5 = 41.5$
MT 0650:	$h_{G'} = h_G + 3.2 = 60.2$
MT 0950:	$h_{G'} = h_G + 3.5 = 83.5$
MT 1250:	$h_{G'} = h_G + 3.5 = 99.5$
MT 1300:	$h_{G'} = h_G + 7.0 = 127.0$

In the case of the type MT 0475, with the bend radius $KR = 75$ mm no glide shoes can be used.

Dimensions in mm

Minimized hinge wear owing to the "life extending 2 disc principle"

In the M Series*, the push and pull forces are transmitted via the optimum link design for this purpose.

As a result link wear is reduced to a minimum and the life of the cable carrier is considerably lengthened.

* not for type 0320

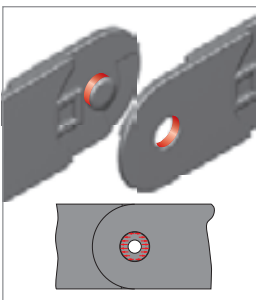

■ Force transmission with a pin-hole joint

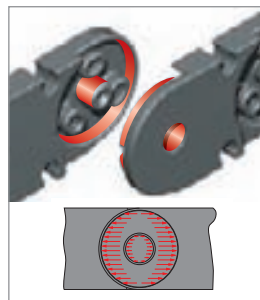

■ Force transmission with the "life extending 2 disc principle"

Use our free project planning service.

XLT Series

TUBES with variable chain widths

- Aluminium cover systems available in 1 mm width sections
- Large dimensions
- Can be quickly opened on the inside and outside for cable laying
- Highly wear-resistant, replaceable glide shoes available – resulting in minimal wear at high speeds, sliding in the guide channel
- Different connection variants
- Different ways of separating the cables
- Optionally with strain relief
- TÜV design approved in accordance with 2PFG 1036/10.97

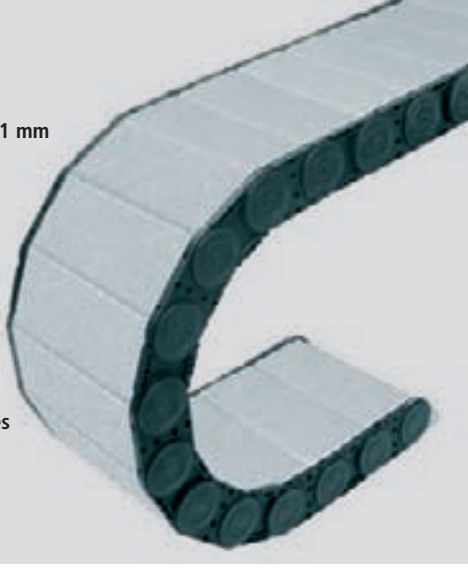

Inside height



Inside widths



kabelschlepp.de

Type XLT with aluminium cover system (stay variant RMD)

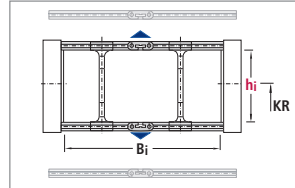

Type	h _i	B _i	Maximum travel length in m	Dynamics of unsupported arrangement		Page
				Travel speed v _{max} in m/s	Travel acceleration a _{max} in m/s ²	
XLT 1650	105	200-1000	300	4	20	238

Dimensions in mm

Font:

+49 2762 4003-0

Carrier construction and cover system

WIDTH SECTIONS



Available in 1 mm width sections.

RMD cover system made of aluminium – old version

Bolted, high stability, large carrier widths



Type XLT 1650

Dimensions and intrinsic chain weight

Inside height
105

Inside widths
200
1000

Type	Stay variant	h _i	h _G	B _i min	q _k min	B _i max	q _k max	B _k
XLT 1650	RMD	105	140	200	17	1000	50	B _i + 68

Dimensions in mm

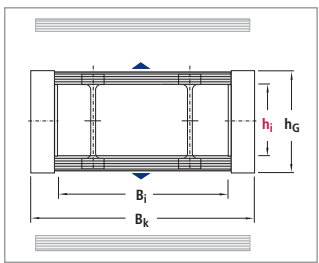

kabelschlepp.de

Bend radius and pitch

Type	Bend radii KR mm						
XLT 1650	250	300	350	400	450	500	550

Pitch t = 165 mm

Load diagram

for unsupported length L_f depending on the additional load

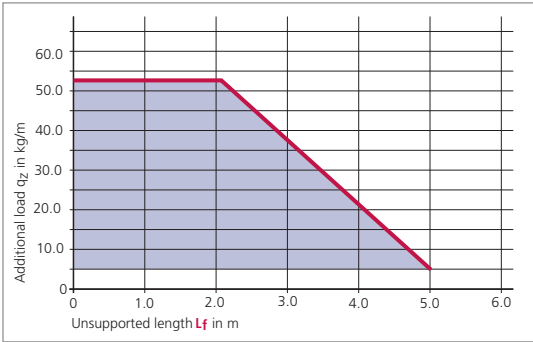

Unsupported length L_f

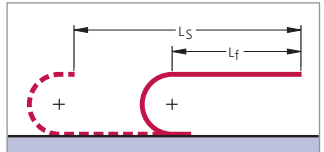

In the case of longer travel lengths, sag of the cable carriers is technically permissible depending on the application.

In a gliding arrangement, even longer travel lengths are possible (see page 295).

We are at your service to advise on these applications.

Fon: +49 2762 4003-0

Use our free project planning service.

Example of ordering

Cable carrier					Divider system		Connection
XLT 1650	700	RMD	400	4950	TS 0	4	FA/MA
Type	Inside width B _i in mm	Stay variant	Bend radius KR in mm	Chain length* L _k in mm (without connection)	Divider system	Number of dividers n _T	Connection Fixed point/Driver

Ordering divider systems:

Please state the designation of the divider system (TS 0, TS 1 ...) and the number of dividers. Possibly attach a sketch with the dimensions.

* The calculated chain length L_k must always be rounded to an odd number of chain links.

Type XLT 1650

Divider system TS 0

Type	Stay variant	h _i mm	S _T mm	a _T min mm	a _x min mm
XLT 1650	RMD	105	8	6	25

The dividers can be moved in the cross section.

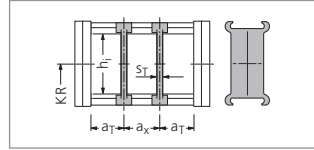

In the standard version, the divider systems are mounted on every second chain link.

Inside height



Inside widths



Divider system TS 3 with section subdivision, partitions made of plastic

Type	Stay variant	h _i mm	S _T mm	a _T min mm	a _x min mm	S _H mm	h ₁ mm	h ₂ mm	h ₃ mm	h ₄ mm	h ₅ mm
XLT 1650	RMD	105	8	1	16*	4	14	28	42	56	70

* When using plastic partitions

The dividers are fixed by the partitions, the complete divider system is movable.

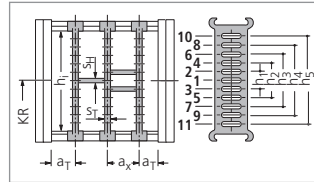

In the standard version, the divider systems are mounted on every second chain link.

kabelschlepp.de

Dimensions of the plastic partitions for TS 3

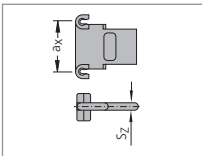

Sz	a _x (center-to-center dividers)										
4	16	18	23	28	32	33	38	43	48	58	
	64	68	78	80	88	96	112	128	144	160	
	176	192	208	-	-	-	-	-	-	-	-

Dimensions in mm

Aluminium partitions in 1 mm width sections are also available.

When using partitions with a_x > 112 mm there should be an additional central support with a twin divider (S_T = 5 mm).

Twin dividers are designed for subsequent fitting in the partition system.

Fon: +49 2762 4003-0

Gliding elements – the economical solution for gliding applications

Replaceable glide shoes made of plastic

To extend the life of cable carriers in gliding operations KABELSCHLEPP supplies detachable, exchangeable glide shoes.

Replaceable glide shoes are a very economical solution. When wear occurs only the glide shoes are replaced, and not the complete cable carrier.

Chain height with glide shoes:

$$h_G' = 147 \text{ mm}$$



By means of a positive snap connection, the glide shoes sit firmly on the chain link.

OnlineEngineer.de
KABELSCHLEPP
Cable Carrier Configurator

Type XLT 1650

Connectors made of steel plate

Inside height



Inside widths

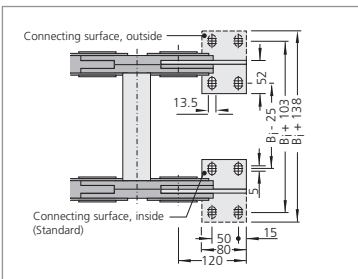
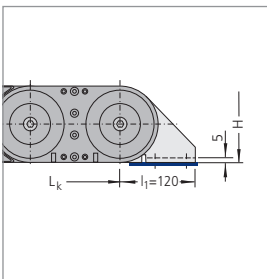

The dimensions of the fixed point and driver connections are identical.

kabelschlepp.de

Connection variants

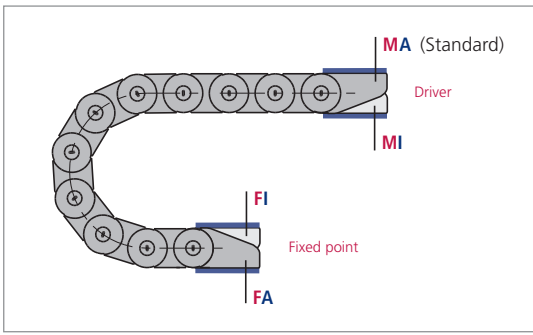

Connection point

- M** – Driver
- F** – Fixed point

Connection type

- A** – Threaded joint (standard)
- I** – Threaded joint, inside

In the standard version, the connectors are mounted with the threaded joint outwards (**FA/MA**).

When ordering please specify the desired connection type (see ordering key on page 337).

The connection type can subsequently be altered.

Fon: +49 2762 4003-0

Use our free project planning service.

Guide channels
 ▶ from page 295



Strain relief devices
 ▶ from page 302



Cables for cable carrier systems
 ▶ from page 344



Steel Cable Carriers – STEEL TUBES

The solution for extreme applications. Cable carriers with chainbands made of galvanized steel and of high-grade stainless steel

- Available in 1 mm section widths
- Extremely robust stable steel chains for heavy mechanical loads and harsh environmental conditions
- Long unsupported lengths also for large additional loads
- Various types available in different dimensions
- Link design with special bolts for a long service life



Inside heights



Inside widths



kabelschlepp.de

Types S/SX 0650, 0950, 1250, 1800

Type	h _i	B _i	Bend radii in mm		Travel length L _s in m	
			min.	max.	Unsupported arrangement*	Maximum travel length
S/SX 0650	30	70-400	75	300	6	60
S/SX 0950	44	125-600	125	410	9	60
S/SX 1250	69	130-800	145	1000	12	150
S/SX 1800	104	250-1000	265	1405	18	200

* Max. value for type S

Dimensions in mm

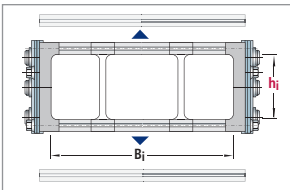

Fon: +49 2762 4003-0

Detailed information on STEEL TUBES can be found on page 269 onwards.

OnlineEngineer.de
KABELSCHLEPP
Cable Carrier Configurator

Inside heights

25
-
72

Inside widths

45
-
162

kabelschlepp.de

Fon: +49 2762 4003-0

Use our free project planning service.

CONDUFLEX

Designer TUBES

- Attractive appearance owing to high-grade steel brackets and fiberglass reinforced polyamide frame
- Very well sealed design
- With protective straps ideal for hot chips
- Optimum protection for cables and hoses
- Quiet operation due to small pitch
- Easy replacement of the crossbars in the case of external damage is possible
- Easy to shorten or extend at a later date
- TÜV type tested in accordance with 2 Pfg 1036/10.97

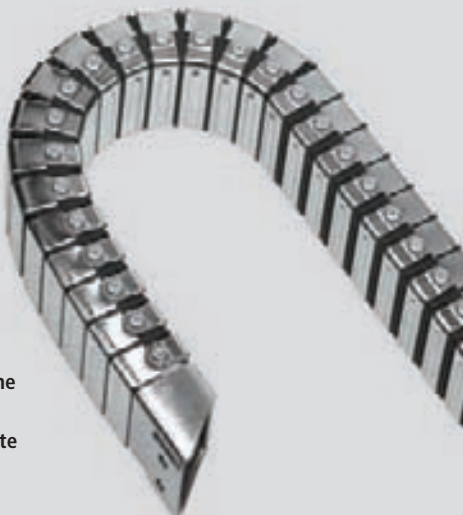

Types CF 055, 060, 085, 115, 120, 175

Type	h_i	B_i	Maximum travel length in m	Dynamics of unsupported arrangement	
				Travel speed v_{max} in m/s	Travel acceleration a_{max} in m/s^2
CF 055	25	45	3.0	10	20
CF 060	40	36	3.5	10	20
CF 085	38	73	4.0	8	18
CF 115	52	102	5.0	8	16
CF 120	70	100	5.5	6	15
CF 175	72	162	6.0	6	12

Dimensions in mm

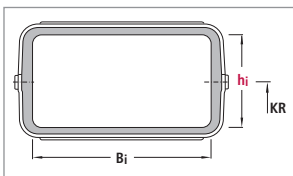

Detailed information on designer TUBES CONDUFLEX can be found on page 282 onwards.

MOBIFLEX

Flexible metal helical TUBES

- Very well sealed design
- Ideal in case of hot metal chips
- Optimum protection for cables and hoses
- Unsupported thanks to the inserted, pre-tensioned steel band



Inside heights



Inside widths



kabelschlepp.de

Font: +49 2762 4003-0

OnlineEngineer.de
KABELSCHLEPP
Cable Center Configurator

Types MF 030, 050, 080, 110, 170

Type	h_i	B_i	Maximum travel length in m	Dynamics of unsupported arrangement	
				Travel speed v_{max} in m/s	Travel acceleration a_{max} in m/s ²
MF 030.1	24	26	2.0	10	20
MF 050.1	24	45	3.0	10	20
MF 050.2	44	45	3.0	10	20
MF 080.1	40	80	3.5	10	18
MF 080.2	54	80	3.5	10	18
MF 080.3	78	80	3.5	10	18
MF 110.1	53	109	4.0	6	15
MF 110.2	73	109	4.0	6	15
MF 110.3	108	109	4.0	6	15
MF 170.1	72	170	5.0	6	12
MF 170.2	102	170	5.0	6	12
MF 170.3	167	170	5.0	6	12

Dimensions in mm

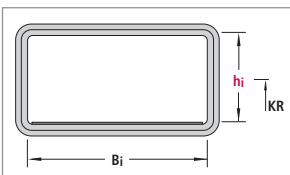

ROBOTRAX

the power to innovate



3D-LINE – ROBOTRAX

Cable carriers for 3D movements

- For three-dimensional movements
- Can be deployed on robots for swiveling and rotational movements: The same system for robot feet and arms
- With channel system, it is a universal solution for rotary applications
- Also ideally suited for rotary tables
- Optimum system for long service life of the cables:
 - The minimum bend radius can be maintained
 - The cables are cleanly isolated in three separate chambers

Special plastic for long service life

Easy fastening on every chain link with quick-opening mounting bracket possible

Steel cable for transmission of extremely large tensile forces

Open design
 – Fast cable laying by simple pressing in of the cables – no threading through is necessary
 – Simple inspection of all the cables



Protective covers or heat shields made of different materials are available for different environmental conditions



Inside heights



Inside widths



kabelschlepp.de

Fon: +49 2762 4003-0

OnlineEngineer.de
with KABELSCHLEPP
 Cable Carrier Configurator

ROBOTRAX accessories

Impact protection	Chucking device	LineFix saddle-type clamps for strain relief*	Bend radius determiner	Quick-opening bracket on a rotary plate	Quick-opening bracket on a helical spring

Subject to change.

* for types R075, R085 and R100

ROBOTRAX – cable carrier for 3D movements

Design principle

Inside heights

10
—
31

Inside widths

27
—
64



Chain links

The basic structure of ROBOTRAX consists of plastic links.

These have ball and socket style snap-together connectors on both sides. The individual links can thus be snapped together to form a cable carrier.

Internal bend radius stoppers ensure that the minimum bend radius is maintained in all directions.

Radial link rotation movement is also possible (see table).



Steel wire and shim bolts

When the robot arms are moving quickly, high accelerations occur, exerting high pulling forces on the cable carrier.

To be able to transmit these pulling forces ROBOTRAX has a hole in the middle of every chain link, through which a steel wire is drawn. This steel wire adopts the role of force transmission. The steel wire has a shim bolt attached to each end. As a result ROBOTRAX can achieve accelerations up to 10 g and higher.

Long service life of the cables and hoses:

The forces are transmitted by the cable carrier and not by the cables and hoses.



Quick-opening mounting brackets

The fixing and further guidance of the ROBOTRAX (on the arms of the robot) is achieved by means of quick-opening mounting brackets, fastened with two screws.

The quick-opening mounting brackets fit any chain link.

The fastening points can therefore be individually matched to the movement sequence of the robot.



Quickly opened:

Simply unlock the lynch pin, pull it out and open the quick-opening mounting bracket.

ROBOTRAX – cable carrier for 3D movements

Dimensions

Dimensions of ROBOTRAX cable carrier

Type	R 040	R 056	R 075	R 085	R 100
For cable-Ø	2 – 8.5	2 – 11	3 – 18	3 – 20	3 – 27
Bend radius	80	115	145	175	195
Radial link rotation over 1 m length	± 450°	± 300°	± 215°	± 215°	± 215°
D _a	40	56	75	85	100
B _i	27	39	52	54	64
h _i	10	14	22	24	31
t	21.5	32	40	40	40

Dimensions in mm

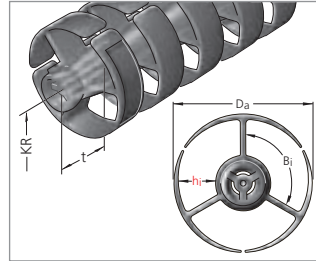

Inside heights



Inside widths



Dimensions of ROBOTRAX quick-opening bracket

Type	R 040	R 056	R 075	R 085	R 100
h ₁	54	70	86	105	120
l ₁	15	22	28	30	32
b ₁	82	86	110	133	150
b ₂	50	63	82	96	112
b ₃	36	48	64	72	70
b ₄	18	24	32	36	35

Dimensions in mm

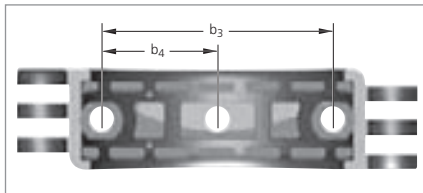
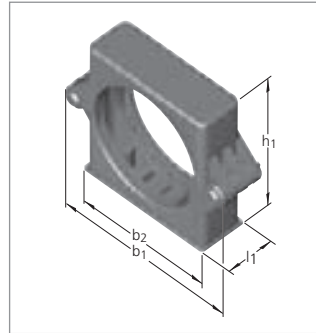

Screwing of the quick-opening bracket:

- R 040, R 056 with M4 hexagonal screws
- R 075 with M6 hexagonal screws
- R 085, R 100 with M8 hexagonal screws

Example of ordering

Cable carrier				
R 075	·	010	-	145 - 1000
Type		Design*		Bend radius KR in mm Chain length L _k in mm (without connection)

* Design 010 (simple insertion of the cables)

Ordering accessories: please state separately.

kabelschlepp.de

Font: +49 2762 4003-0

OnlineEngineer.de
KABELSCHLEPP
Cable Carrier Configurator

ROBOTRAX – accessories

Inside heights

10
—
31

Inside widths

27
—
64



Impact protection

When a robot is moving, a striking of the ROBOTRAX against machine components often cannot be avoided.

An impact protective device made of elastomer plastic can easily be attached to each link using a cable tie.



Heat shield/Protective sleeve

Heat shield: The heat shield, made of aluminium-coated textile fiber, protects the cable carrier and the cables within from flying sparks. A heat shield is recommended where there are flying sparks.

Protective sleeve: The protective sleeve made of layered polyester offers protection against aggressive cutting and hydraulic oils as well as from fine dusts and paint sprays (not illustrated).



Chucking device

This can be used to set the steel wire to the desired tension quickly and easily, and can be readjusted at any time.



Strain relief

For securing the cables and hoses.

(A strain relief device cannot be used on the same end of the ROBOTRAX as a chucking device.)



Strain relief with LineFix saddle-type clamps LFR

(for types R075, R085 and R100)

For secure and gentle cable fixing.

Multilayer strain relief with double and triple clamps possible. Multiple systems can also be mounted one behind the other.

ROBOTRAX – accessories



Bend radius determiner

This is used to achieve larger bend radii than the standard bend radius, e.g. in order to maintain the minimum bend radius of the cables.



Quick-opening bracket mounted on a rotary plate

Yet one more degree of freedom on the fastening points.

The quick-opening mounting bracket can also rotate on a rotary plate, thus providing greater flexibility when the robot is performing complex movements.

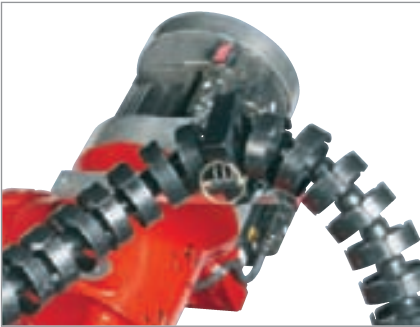

Quick-opening bracket on a helical spring

If the bracket is mounted on a helical spring, it can give elastically in all directions, swivel, swing out in 3 dimensions and spring back into place again.



Inside heights



Inside widths



kabelschlepp.de

Font: +49 2762 4003-0

OnlineEngineer.de
KABELSCHLEPP
Cable Center Configurator

ROBOTRAX – cable carrier for 3D movements

Part numbers for ordering

Inside heights



Inside widths

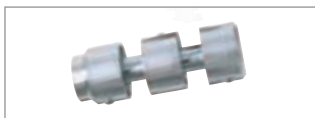

Mounted chain links

Type	R 040	R 056	R 075	R 085	R 100
Bend radius	80	115	145	175	195
Number of links	47	31	25	25	25
Part no.	60301	60401	60501	60601	60701

Quick-opening bracket for ROBOTRAX

Type	R 040	R 056	R 075	R 085	R 100
Part no.	260410	260510	260110	260210	260310

Shim bolts – 2 pieces (one pair)

Type	R 040	R 056	R 075	R 085	R 100
Part no.	260420	260520	260220	260220	260320

Steel wire – Please specify total length or partial lengths

Type	R 040	R 056	R 075	R 085	R 100
Ø	1.8	2.5	3.0	3.0	4.0
Part no.	60583	60584	60580	60580	60581

Strain relief – 1 piece

Type	R 040	R 056	R 075	R 085	R 100
Part no.	60658	60657	60659	60659	60659

Locating bolt for LineFix strain relief LFR – 1 piece

Type	R 075	R 085	R 100
Part no.	60669	60669	60669

LineFix strain relief – see page 302.

Chucking device set – 1 chucking device and 1 shim bolt

Type	R 040	R 056	R 075	R 085	R 100
Part no.	260430	260530	260230	260230	260330

Impact protection

Type	R 075	R 085	R 100
Part no.	260120	260240	260340

Packing unit: 5 complete items
consisting of: 10 semi-circular shells and 5 cable ties

ROBOTRAX – cable carrier for 3D movements

Part numbers for ordering

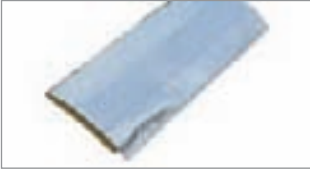

Heat shield/Protective sleeve

Type	R 040	R 056	R 075	R 085	R 100
Heat shield	60801	60802	60803	60804	60805
Protective sleeve (not illustrated)	60806	60807	60808	60809	60810

Please specify total length or partial lengths.

Inside heights



Inside widths

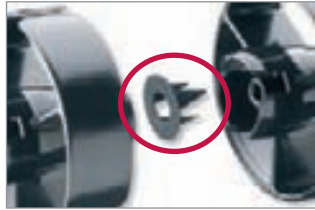

Bend radius determiner

Type	R 075	R 085	R 100
Part no. 60830	160	230	280
Part no. 60831	190	265	310
Part no. 60832	220	300	340
Part no. 60833	250	335	370
Part no. 60834	280	370	400
Part no. 60835	310	405	430
Part no. 60836	340	440	460
Part no. 60837	370	475	490
Part no. 60838	400	510	520
Part no. 60839	430	545	550

Dimensions in mm

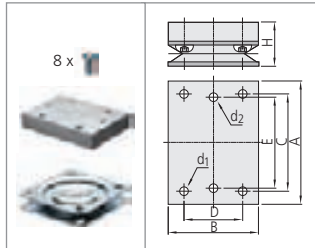

Rotary plate for quick-opening bracket

Type	R 040	R 056	R 075	R 085	R 100
A	57	65	82	96	112
B	57	57	57	70	70
C	43	43	43	75	75
D	43	43	43	45	45
E	36	48	64	72	70
H	25	25	25	34	34
d ₁	M6	M6	M6	M6	M6
d ₂	M4	M4	M6	M8	M8
Part no.	260580	260590	260550	260560	260570

Appropriate screws are supplied with the rotary plate. Dimensions in mm

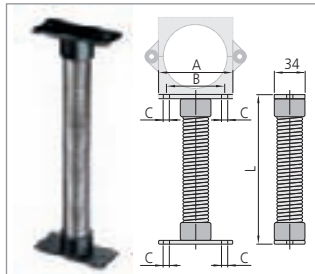

Helical spring for quick-opening bracket

Type	R 040	R 056	R 075	R 085	R 100
A	52	64	82	96	112
B	36	48	64	72	70
C	5	5	6.5	8.5	8.5
Length L = 110 mm Part no.	260600	260620	–	–	–
Length L = 150 mm Part no.	260610	260630	–	–	–
Length L = 165 mm Part no.	–	–	60816	60820	60824
Length L = 190 mm Part no.	–	260640	–	–	–
Length L = 230 mm Part no.	–	–	60817	60821	60825
Length L = 315 mm Part no.	–	–	60818	60822	60826
Length L = 465 mm Part no.	–	–	60819	60823	60827

Dimensions in mm

kabelschlepp.de

Fon: +49 2762 4003-0

OnlineEngineer.de
KABELSCHLEPP
Cable Carrier Configurator



Selection

BASIC
LINE

BASIC
LINEPLUS

VARIO
LINE

TUBE
SERIES

3D
LINE

STEEL-LINE

Steel cable carriers – solutions for extreme applications

- Robust design for heavy mechanical loads
- High additional loads and long unsupported lengths possible
- Best suited for extreme and particular environmental influences
- Heat-resistant



LS/LSX Series

Cost-effective steel chains with light design

page 254



S/SX Series

Extremely robust and stable steel chains

page 262



CONDUFLEX

Closed designer cable carrier

page 282



MOBIFLEX

Enclosed cable carrier with flexible metal helical tube

page 288

LS/LSX Series

The power to innovate



LS/LSX Series

Cost-effective steel chains with light design

- Improved dynamic characteristic values due to weight-optimized design
- Long unsupported lengths for small to medium additional loads
- Cover with steel band for protecting the cables is available on request



Optional central bolt for applications with large loads

C-rail for strain relief elements

Strokes are integrated in the chain link plate – no additional bolts are needed

End connectors for different connection variants

Favorable ratio of inner to outer width – no peripheral divider necessary

Weight-optimized chain bands – specially coated or stainless steel

STEEL
SPECIAL COATED

STAINLESS STEEL
RUST-FREE

Different stay variants available in 1 mm width sections

WIDTH SECTIONS
1 mm

Dividers made of plastic or steel

Various cable separation options

Inside height

58

Chain widths

100 - 600

kabelschlepp.de

Font:

+49 2762 4003-0

The design

The chains are very light and yet very stable due to the weight-optimized link plate design. The unsupported length for the LS series is significantly higher as compared with plastic chains of the same size.



Weight-optimized link plates only consist of one plate – the stroke system is integrated



Light sidebands without additional bolts – special coating or stainless steel



Optional: Central bolt and locking ring for applications involving large loads



Optional: C-Rail for strain relief elements fixed in the connection

Type LS/LSX 1050

- **Type LS:**
Chain bands made of specially coated steel
- Type LSX:**
High-grade stainless steel chainbands
- Available in 1 mm width sections

Inside height
58

Chain widths
100 - 600

WIDTH SECTIONS
1 mm

Type	h _i	B _k	Maximum travel length ^{A)} in m	Dynamics of unsupported arrangement	
				Travel speed ^{B)} v _{max} in m/s	Travel acceleration a _{max} in m/s ²
LS/LSX 1050	58	100-600	10	5C)	10

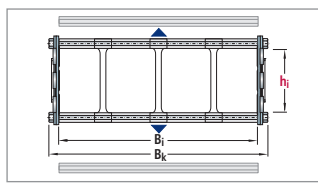

The values h_i and B_k are dependent on the stay variant.
 A) Values LS versions;
 LSX versions see load diagram
 B) Values for LSX versions reduced by 0.5 m/s
 C) Maximum value

Design guidelines for central bolts and stay arrangement: Dimensions in mm

- Chain length > 4 m:
central bolts **or** stay arrangement on every chain link necessary
- Chain width B_{St} > 400 mm:
central bolts **or** stay arrangement on every chain link necessary
- Travel speed > 2,5 m/s:
Central bolt **or** fully-stayed arrangement necessary
- Use of support rollers:
central bolts **and** stay arrangement on every chain link necessary

kabelschlepp.de

Bend radius and pitch

Type	Bend radii KR mm								
LS/LSX 1050	105	125	155	195	260	295	325	365	430

Pitch: t = 105 mm

Load diagram

for unsupported length L_f depending on the additional load*

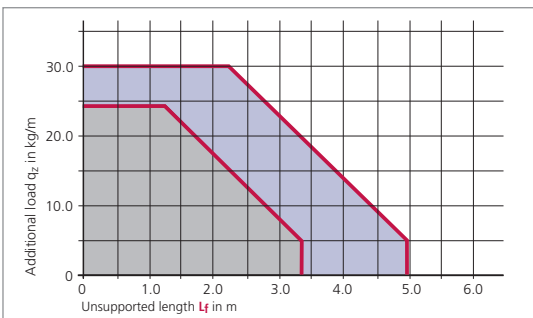

Unsupported length L_f

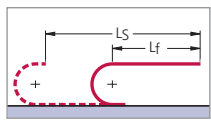

Determining the length of the cable carrier see page 41.

- * Load diagram for stay variant RS for medium carrier widths. The possible additional load for large carrier widths and heavy stay variants (e.g. RR) is smaller due to the increased intrinsic chain weight.
- With black special coating
- Material ER 1, ER 1S and LS 1050 with galvanized surface

Example of ordering

Cable carrier	Divider system	Connection
LS 1050 - 180 - RS 2 - 125 - Sb - 2415	TS 0 / 4	FA/MA
Type Stay width B _{St} in mm Stay variant Bend radius KR in mm Chain band material Chain length L _k in mm (without connection)	Divider system Number of dividers n _T	Connection Fixed point/Driver

Chain band materials: Sb = Steel specially coated / ER 1 = Stainless steel / ER 1S = Stainless steel, sea water resistant. Please contact us for further information about the chain band materials.

Ordering divider systems: Please state the designation of the divider system (TS 0, TS 1 ...) and the number of dividers. Possibly attach a sketch with the dimensions.

Fon: +49 2762 4003-0
Use our free project planning service.

Type LS/LSX 1050

Stay variant RS 2 – with bolted stays

- frame stay RS made of aluminium – standard design
- for lightweight to medium loads
- **Standard stay arrangement:** on every 2nd chain link. Stays can be fitted on every chain link, please specify when placing your order.
- bolted stays for maximum stability

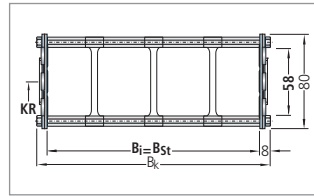

Inside height

58

Chain widths

100 - 600

Dimensions and intrinsic chain weight

Type	Stay variant	h _i	h _G	B _k min	q _k min	B _k max	q _k max	B _i	B _{St}	WIDTH SECTIONS
LS/LSX 1050	RS 2	58	80	100	3.7	400	4.2	B _k - 16	B _{St} = B _i	1 mm

Dimensions in mm/Weights in kg/m

Stay variant RV – frame stay, reinforced design

- frame stay RV made of aluminium – reinforced design
- for medium to heavy loads and for large chain width
- **Standard stay arrangement:** on every 2nd chain link. Stays can be fitted on every chain link, please specify when placing your order.
- bolted stays for maximum stability

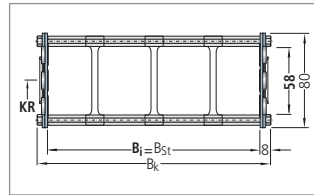
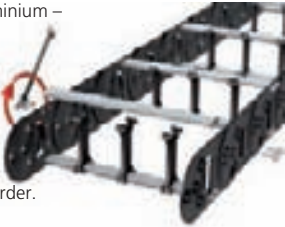

Dimensions and intrinsic chain weight

Type	Stay variant	h _i	h _G	B _k min	q _k min	B _k max	q _k max	B _i	B _{St}	WIDTH SECTIONS
LS/LSX 1050	RV	58	80	100	4.0	600	5.9	B _k - 16	B _{St} = B _i	1 mm

Dimensions in mm/Weights in kg/m

kabelschlepp.de

Font: +49 2762 4003-0

OnlineEngineer.de
KABELSCHLEPP
Cable Center Configurator

Type LS/LSX 1050

Stay variant RR – frame stay, tube design

Inside height
58

Chain widths
100
600

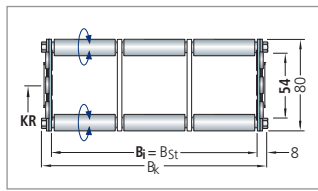

- gentle cable support due to rotating metal tubes
- ideal when using media hoses with "soft" sheaths
- possible materials of the axles, tubes and dividers:
 - axles, tubes and dividers made of galvanized steel (standard)
 - axles, tubes and dividers made of stainless steel ER 1
- Standard stay arrangement:** on every 2nd chain link. Stays can be fitted on every chain link, please specify when placing your order.
- bolted stays for maximum stability

kabelschlepp.de

Dimensions and intrinsic chain weight

Type	Stay variant	h _i	h _G	B _k min	q _k min	B _k max	q _k max	B _i	B _{St}
LS/LSX 1050	RR	54	80	100	4.3	500	8.0	B _k – 16	B _{St} = B _i



Dimensions in mm/Weights in kg/m

Fon: +49 2762 4003-0

Stay variant LG – hole stay made of aluminium, split design

- optimum cable guidance in the neutral bending line is possible
- drilling pattern individually adapted to the application
- high stability due to solid construction
- split design as standard for easy laying of the cables
- Standard stay arrangement:** on every 2nd chain link. Stays can be fitted on every chain link, please specify when placing your order.
- bolted stays for maximum stability – also available not split

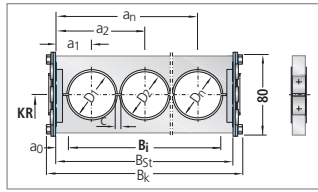
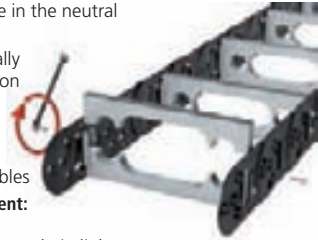

Dimensions and intrinsic chain weight

Type	Stay variant	D max	h _G	B _k min	q _k min*	B _k max	q _k max*	a ₀ min	B _i	B _{St}
LS/LSX 1050	LG	48	80	100	4.1	600	8.1	14	B _{St} – 2 a ₀	B _k – 18



* Listed weights assume that the hole area is approx. 50 % of the stay

Dimensions in mm/Weights in kg/m

Use our free project planning service.

See next page for examples of hole patterns.

Type LS/LSX 1050

Examples of hole patterns:

Split hole stay with individual holes

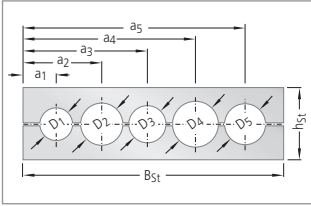

Split hole stay with horizontal and vertical elongated holes*

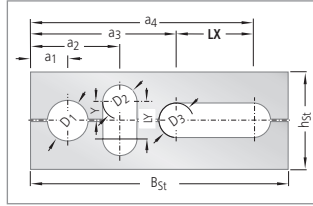

*) With an off-center arrangement of the holes, the cables are subject to a relative movement when the carrier is in motion.

Divider system TS 0 without height subdivision

Type	Stay variant	h _i mm	S _T mm	a _T min mm	a _x min mm
LS/LSX 1050	RS 2	58	4	7	14
LS/LSX 1050	RV	58	4	7	14
LS/LSX 1050	RR	54	4	20	20

The dividers can be moved in the cross section (not for stay variant RR).

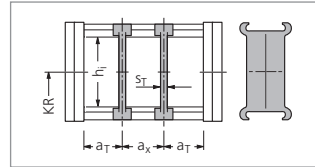

In the standard version, the divider systems are mounted on every second chain link.

Divider system TS 1 with continuous height subdivision made of aluminium

Type	Stay variant	h _i mm	S _T mm	a _T min mm	a _x min mm	S _H mm	h ₁ mm	h ₂ mm
LS/LSX 1050	RS 2	58	4	7	14	4	30	–
LS/LSX 1050	RV	58	4	7	14	4	15	30
LS/LSX 1050	RR	54	4	20	20	8	–	–

The dividers can be moved in the cross section (not for stay variant RR).

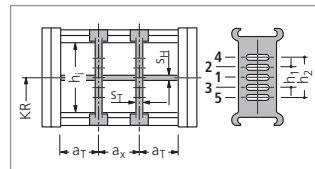

In the standard version, the divider systems are mounted on every second chain link.

Divider system TS 2 with grid subdivision made of aluminium (1 mm grid)

Type	Stay variant	h _i mm	S _T mm	a _T min mm	a _x min mm	S _H mm	h ₁ mm	h ₂ mm
LS/LSX 1050	RS 2	58	4	7	20	4	30	–
LS/LSX 1050	RV	58	6	7	20	4	15	30

The dividers can be moved in the cross section

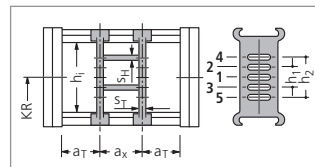

In the standard version, the divider systems are mounted on every second chain link.

Type LS/LSX 1050

Divider system TS 3 with section subdivision, partitions made of plastic

Inside height
58

Type	Stay variant	h _i mm	S _T mm	a _T min mm	a _x min mm	S _H mm	h ₁ mm	h ₂ mm	h ₃ mm
LS/LSX 1050	RV	58	8	4	16*	4	14	28	42

* When using plastic partitions
The dividers are fixed by the partitions, the complete divider system is movable.

Chain widths
100 - 600

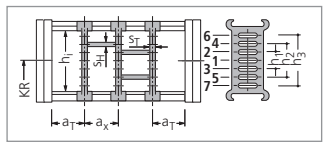

In the standard version, the divider systems are mounted on every second chain link.

Dimensions of the plastic partitions for TS 3

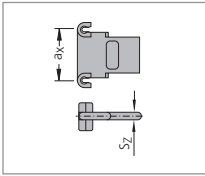

S _z	a _x (center-to-center distance, dividers)									
4	16	18	23	28	32	33	38	43	48	58
	64	68	78	80	88	96	112	128	144	160
	176	192	208	-	-	-	-	-	-	-

Dimensions in mm

When using partitions with a_x > 112 mm, there should be an additional central support with a twin divider (S_T = 4 mm).
Twin dividers are designed for subsequent fitting in the partition system.

kabelschlepp.de

Aluminium partitions in 1 mm width sections are also available.

Strain relief devices

The C-Rails are fixed together with the end connectors and thus do not have to be bolted separately.

Length of the C-Rail L_p:
Fixed point: L_p = B_i
Driver: L_p = B_i + 4 mm



■ C-rail fixed in the end connector.

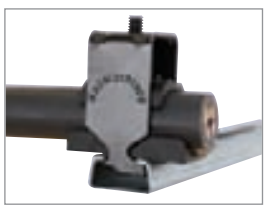

■ Liniflex bracket clamp in C-rail

Integratable C-Rail

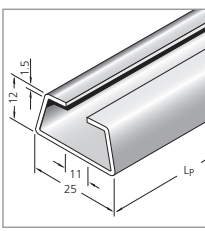

Suitable for all commercially available brackets (slot width 11 mm)
Material Steel
Item-No. 3934
See also Accessories chapter, page 293.



■ Inserting the C-rail in the end connector.



Use our free project planning service.

Guide channels
➤ from page 295



Strain relief devices
➤ from page 302



Cables for cable carrier systems
➤ from page 344



Type LS/LSX 1050

End connectors

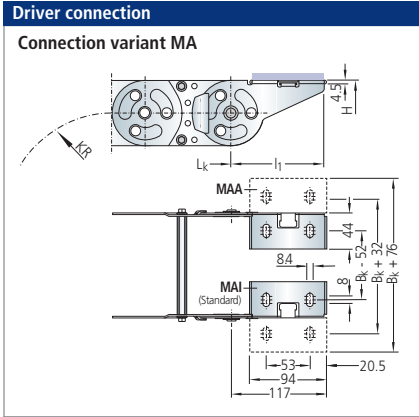
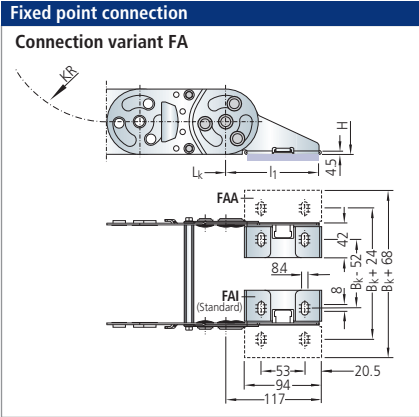

Different connection variants for fixed point and driver are possible according to the drawing information. Different end connectors are needed for different connection variants.

Please state the desired connection variant according to the ordering key.

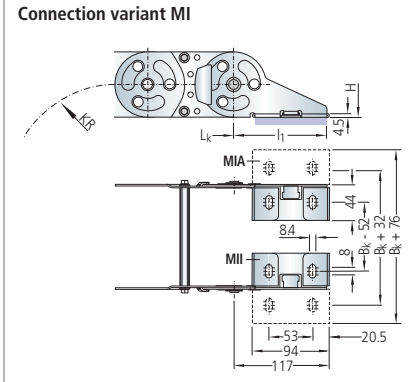

Connection variants

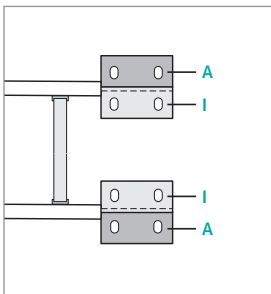
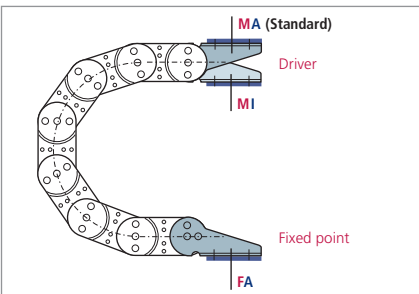

Connection point

- M** – Driver
- F** – Fixed point

Connection type

- A** – Threaded joint outside (standard)
- I** – Threaded joint, inside

Connecting surface

- I** – Connecting surface inside (< Bk)
- A** – Connecting surface outside (> Bk)

Inside height



Chain widths



kabelschlepp.de

Font: +49 2762 4003-0

OnlineEngineer.de
with Concepts
 Cable Center Configurator

s/sx Series
The power to innovate



S/SX Series

Extremely robust and stable steel chains*

- Extremely robust and stable steel chains for heavy mechanical loads and harsh environmental conditions
- Very long unsupported lengths also for large additional loads
- Various types available in different dimensions
- Covers with aluminium cover system or steel strip possible for protection of the cables

Inside heights



Chain widths



- End connectors for different connection variants
- Extremely robust chain bands galvanized or made of stainless steel

STEEL
GALVANIZED

STAINLESS STEEL
RUST-FREE

- Different stay variants available in 1 mm width sections



- Aluminium cover available in 1 mm width sections



Link design with special bolts for a long service life

The design

Steel cable carriers proven over many years with extremely stable chain link plates and a link design with multiple stroke system and special bolts. Large unsupported lengths and high additional loads are possible due to the extremely stable design.

- Dividers made of plastic or steel

- Various cable separation options

kabelschlepp.de

Fon: +49 2762 4003-0

OnlineEngineer.de
KABELSCHLEPP
Cable Carrier Configurator



Sandwich design: Chain link plates consist of two plates welded together



Glide shoes for gliding applications are available



Stroke system with special bolts and locking rings



Also available as covered variants with cover system or steel band covering

Overview S/SX Series

Types S/SX 0650, 0950, 1250, 1800

- Available in 1 mm width sections

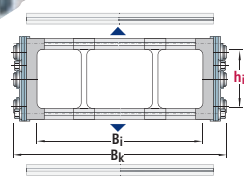
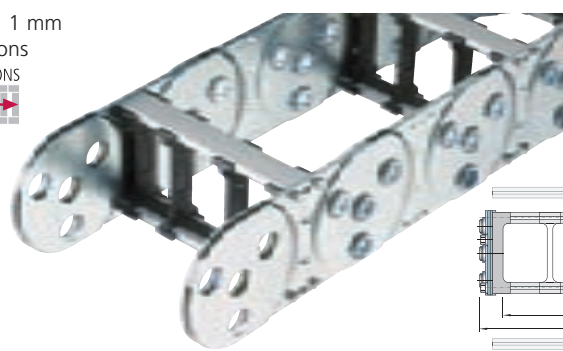

Type	hi	Bk	Maximum travel length unsupported arrangement ^{A)} in m	Dynamics of unsupported arrangement		Page
				Travel speed ^{B)} v _{max} in m/s	Travel acceleration a _{max} in m/s ²	
S/SX 0650	31	70-500	6	2.5	5.0	266
S/SX 0950	46	125-600	9	2.5	5.0	266
S/SX 1250	72	130-800	12	2.5	5.0	266
S/SX 1800	108	180-1000	18	2.0	3.0	266

A) Values S versions; SX versions see load diagram of the respective type

B) Values for SX versions reduced by 0.5 m/s

The values hi and Bk are dependent on the stay variant.

Dimensions in mm

Fon: +49 2762 4003-0

STEEL TUBES – Types S/SX 0650 – 1800

- Aluminium cover system
- Available in 1 mm width sections



Detailed information for the stay variant RMD can be found on page 269.

Use our free project planning service.

Overview S/SX Series

Types S/SX 2500 and 3200

- Available in 1 mm width sections

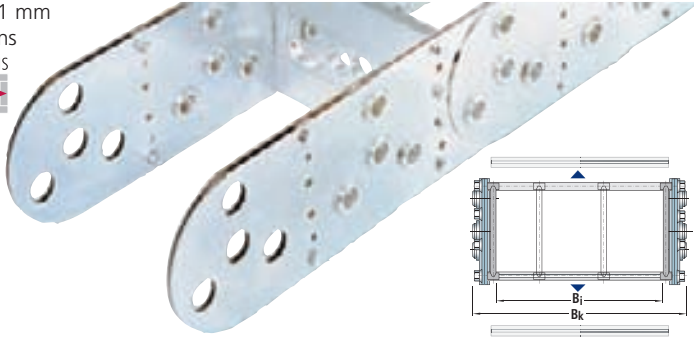

Inside heights



Chain widths



Type	hi	Bk	Maximum travel length unsupported arrangement ^{A)} in m	Dynamics of unsupported arrangement		Page
				Travel speed ^{B)} v _{max} in m/s	Travel acceleration a _{max} in m/s ²	
S/SX 2500	183	250-1200	24	2.0	3.0	274
S/SX 3200	220	250-1500	25	2.0	2.5	274

A) Values S versions; SX versions see load diagram of the respective type

B) Values for SX versions reduced by 0.5 m/s

Dimensions in mm

The values hi and Bk are dependent on the stay variant.

kabelschlepp.de

Types S/SX 5000 to 7000

- Available in 1 mm width sections



For applications with extremely large additional loads and very large carrier dimensions. Cable and hose carriers of the types 5000 / 6000 / 7000 are usually special designs for special applications such as in the offshore area for example



Type	hi	Bk	Maximum travel length unsupported arrangement ^{A)} in m	Dynamics of unsupported arrangement		Page
				Travel speed ^{B)} v _{max} in m/s	Travel acceleration a _{max} in m/s ²	
S/SX 5000	150	150-1000	12	2.0	3.0	278
S/SX 6000	240	200-1200	18	1.5	2.0	278
S/SX 7000	370	350-1800	25	1.0	1.0	278

A) Values S versions; SX versions see load diagram of the respective type

B) Values for SX versions reduced by 0.5 m/s

Font: +49 2762 4003-0

OnlineEngineer.de
KABELSCHLEPP
Cable Carrier Configurator

Types S/SX 0650, 0950, 1250, 1800

- **Type S:**
Chainbands made of galvanized steel
- **Type SX:**
Chainbands made of high-grade stainless steel
- **Available in 1 mm width sections**



Bend radius and pitch

Type	Bend radii KR mm												
S/SX 0650	75	95	115	125	135	145	155	175	200	250	300	400	–
S/SX 0950	125	140	170	200	260	290	320	350	410	600	–	–	–
S/SX 1250	145	200	220	260	300	340	380	420	460	500	540	600	1000
S/SX 1800	265	320	375	435	490	605	720	890	1175	1405	–	–	–

Pitch:
 S/SX 0650: t = 65 mm
 S/SX 0950: t = 95 mm
 S/SX 1250: t = 125 mm
 S/SX 1800: t = 180 mm

Intermediate radii upon request.

kabelschlepp.de

Load diagrams

for unsupported length L_f depending on the additional load*

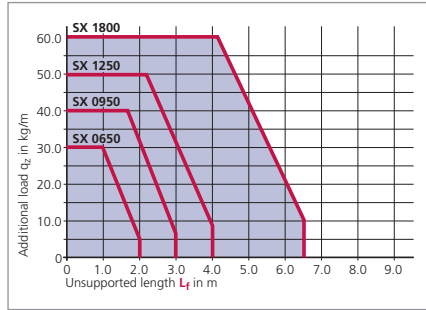
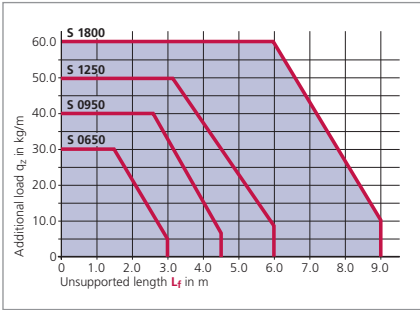

Fon: +49 2762 4003-0

Unsupported length L_f

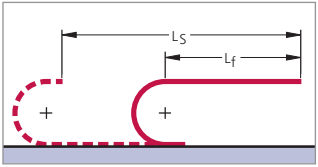

Determining the length of the cable carrier see page 41.

* Load diagram for stay variant RV for medium carrier widths. The possible additional load for large carrier widths and heavy stay variants (e.g. RMD) is smaller due to the increased intrinsic chain weight.

Example of ordering

Cable carrier						Divider system		Connection
S 0950	300	RS 1	200	St	2375	TS 0	4	FA/MA
Type	Stay width B_{St} in mm	Stay variant	Bend radius KR in mm	Chain band material	Chain length L_k in mm (with-out connection)	Divider system	Number of dividers n_T	Connection Fixed point/Driver

Chain band materials: St = Galvanized steel / ER 1 = Stainless steel / ER 1S = Stainless steel, sea water resistant / ER 2 = High-strength stainless steel. Please contact us for further information about the chain band materials.

Ordering divider systems: Please state the designation of the divider system (TS 0, TS 1 ...) and the number of dividers. Possibly attach a sketch with the dimensions.

Use our free project planning service.

Type S/SX 0650, 0950, 1250, 1800

Stay variant RS 2 – with bolted stays

- frame stay RS made of aluminium – standard design
- for lightweight to medium loads
- **Standard stay arrangement:** on every 2nd chain link. Stays can be fitted on every chain link, please specify when placing your order.
- bolted stays for maximum stability

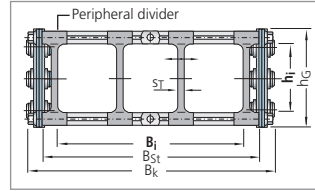
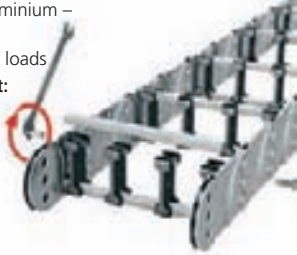

Inside heights

31
-
72

Chain widths

100
-
500

Dimensions and intrinsic chain weight

Type	Stay variant	h _i	h _G	B _k min	q _k min	B _k max	q _k max	B _i	B _{St}	WIDTHSECTIONS
S/SX 0650	RS 2	31	50	100	3.9	400	5.2	B _k – 31	B _i + 16	
S/SX 0950	RS 2	46	68	150	7.5	400	8.2	B _k – 37	B _i + 18	
S/SX 1250	RS 2	72	94	200	12.9	500	13.7	B _k – 44	B _i + 20	

Dimensions in mm/Weights in kg/m

kabelschlepp.de

Stay variant RS 1 – with a detachable stay

- frame stay RS made of aluminium – solid design
- for lightweight to medium loads
- **Standard opening options:**
Outside: The cable carrier can be opened quickly and easily simply by rotating the stays through 90°.
Inside: Screwed stays
Optional: Bolted on the outside and opening inwards, please state when ordering.
- **Standard stay arrangement:** on every 2nd chain link. Stays can be fitted on every chain link, please specify when placing your order.

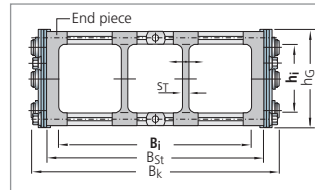
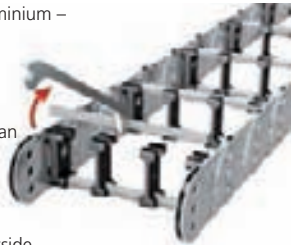

Fon:

+49 2762 4003-0

Dimensions and intrinsic chain weight

Type	Stay variant	h _i	h _G	B _k min	q _k min	B _k max	q _k max	B _i	B _{St}	WIDTHSECTIONS
S/SX 0650	RS 1	31	50	100	3.9	300	4.8	B _k – 35	B _i + 20	
S/SX 0950	RS 1	46	68	150	7.5	300	8.0	B _k – 43	B _i + 24	
S/SX 1250	RS 1	72	94	200	12.9	400	13.5	B _k – 48	B _i + 24	

Dimensions in mm/Weights in kg/m

OnlineEngineer.de
with KABELSCHLEPP
 Cable Carrier Configurator

Types S/SX 0650, 0950, 1250, 1800

Stay variant RV – frame stay, reinforced design

- frame stay RV made of aluminium – reinforced design
- for medium to heavy loads and for large chain width
- **Standard stay arrangement:** on every 2nd chain link. Stays can be fitted on every chain link, please specify when placing your order.
- bolted stays for maximum stability

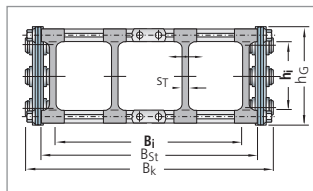
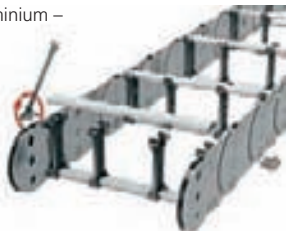

Inside heights
43
108

Chain widths
125
1000

Dimensions and intrinsic chain weight

Type	Stay variant	h _i	h _G	B _k min	q _k min	B _k max	q _k max	B _i	B _{St}
S/SX 1250	RV	72	94	200	13.6	600	17.0	B _k – 46	B _i + 22

Dimensions in mm/Weights in kg/m

WIDTHSECTIONS

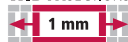

Stay variant RM – frame stay, solid design

- frame stay RM made of aluminium – solid design
- for heavy loads – maximum chain widths possible
- **Standard stay arrangement:** on every 2nd chain link. Stays can be fitted on every chain link, please specify when placing your order.
- bolted stays for maximum stability

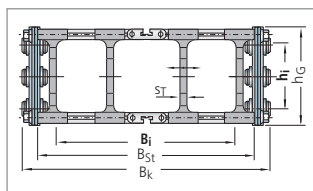
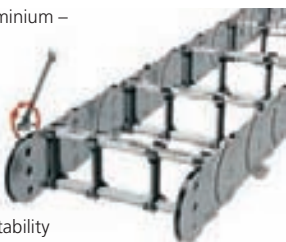

Dimensions and intrinsic chain weight

Type	Stay variant	h _i	h _G	B _k min	q _k min	B _k max	q _k max	B _i	B _{St}
S/SX 0950	RM	43	68	125	7.9	600	10.7	B _k – 37	B _i + 18
S/SX 1250	RM	69	94	200	13.4	800	17.0	B _k – 49	B _i + 25
S/SX 1800	RM	108	140	250	24.0	1000	28.5	B _k – 62	B _i + 33

Dimensions in mm/Weights in kg/m

WIDTHSECTIONS



Fon: +49 2762 4003-0

Use our free project planning service.

Types S/SX 0650, 0950, 1250, 1800

Stay variant RR – frame stay, tube design

- gentle cable support due to rotating metal tubes
- ideal when using media hoses with "soft" sheaths
- possible materials of the axles, tubes and dividers:
 - axles and tubes, galvanized steel with plastic dividers (**Standard**)
 - axles, tubes and dividers made of galvanized steel
 - axles, tubes and dividers made of stainless steel ER 1, ER 1S
- Standard stay arrangement:** on every 2nd chain link. Stays can be fitted on every chain link, please specify when placing your order.
- bolted stays for maximum stability

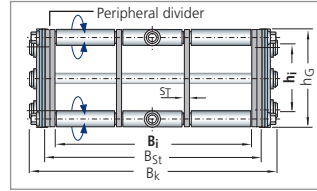
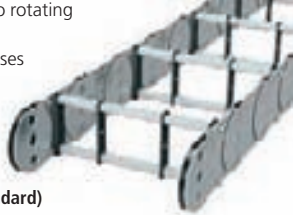

Inside heights

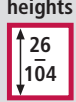

Chain widths



Dimensions and intrinsic chain weight

Type	Stay variant	h_i	h_G	B_k min	q_k min	B_k max	q_k max	B_i	B_{St}
S/SX 0650	RR	26	50	100	4.8	400	8.7	$B_k - 31$	$B_i + 16$
S/SX 0950	RR	42	68	150	8.4	500	11.8	$B_k - 35$	$B_i + 16$
S/SX 1250	RR	66	94	200	13.8	600	17.3	$B_k - 40$	$B_i + 16$
S/SX 1800	RR	104	140	250	26.5	800	36.0	$B_k - 49$	$B_i + 20$

Dimensions in mm/Weights in kg/m

Stay variant RMD – covered cable carrier, STEEL TUBE

- aluminium cover system for protecting the cables and hoses
- for applications where chips or severe contamination occur
- bolted aluminium cover for maximum stability

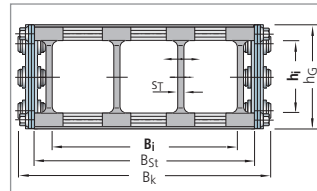
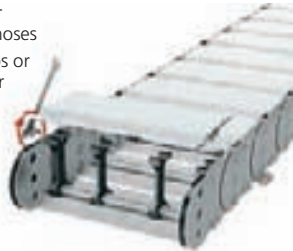

Steel band covers are also available as light-weight, economically priced alternatives to covering with the aluminium cover system, see page 280.



Dimensions and intrinsic chain weight

Type	Stay variant	h_i	h_G	B_k min	q_k min	B_k max	q_k max	B_i	B_{St}	KR_{min}
S/SX 0650	RMD	30	50	100	4.8	500	10.5	$B_k - 35$	$B_i + 20$	115
S/SX 0950	RMD	44	68	125	10.2	600	22.0	$B_k - 37$	$B_i + 18$	170
S/SX 1250	RMD	69	94	150	15.4	800	32.4	$B_k - 49$	$B_i + 25$	200
S/SX 1800	RMD	104	140	250	26.5	1000	46.5	$B_k - 62$	$B_i + 33$	320

Dimensions in mm/Weights in kg/m

WIDTHSECTIONS



Font: +49 2762 4003-0

OnlineEngineer.de
with KABELSCHLEPP
Cable Carrier Configurator

Inside heights
40
110

Chain widths
70
1000

Fon: +49 2762 4003-0

Use our free project planning service.

Types S/SX 0650, 0950, 1250, 1800

Stay variant LG – hole stay made of aluminium, split design

- optimum cable guidance in the neutral bending line is possible
- drilling pattern individually adapted to the application
- high stability due to solid construction
- split design as standard for easy laying of the cables
- **Standard stay arrangement:** on every 2nd chain link. Stays can be fitted on every chain link, please specify when placing your order.
- bolted stays for maximum stability – also available not split

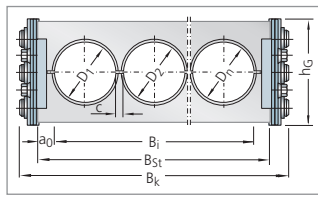
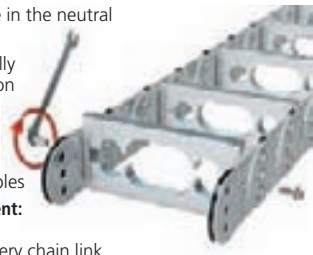

Dimensions and intrinsic chain weight

Type	Stay variant	D max	hG	Bk min	qk min*	Bk max	qk max*	a0 min	B1	BSt
S/SX 0650	LG	40	50	70	4.0	500	6.4	9.0	BSt – 18	Bk – 17
S/SX 0950	LG	48	68	125	8.1	600	11.8	11.0	BSt – 22	Bk – 21
S/SX 1250	LG	74	94	130	13.2	800	18.2	11.0	BSt – 22	Bk – 26
S/SX 1800	LG	110	140	180	24.8	1000	33.0	13.5	BSt – 27	Bk – 32



* Listed weights assume that the hole area is approx. 50 % of the stay.

Dimensions in mm/Weights in kg/m

Selection of some hole patterns:

Split hole stay with individual holes

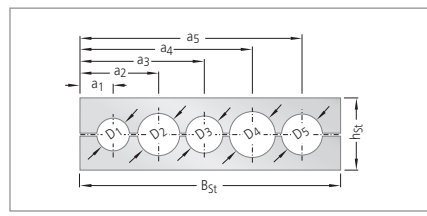

Split hole stay with horizontal and vertical elongated holes*

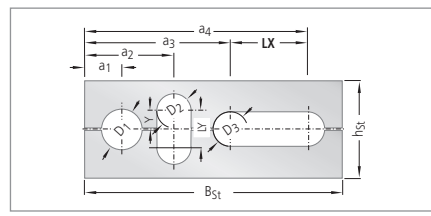

*) With an off-center arrangement of the holes, the cables are subject to a relative movement when the carrier is in motion.

Stay variant LG with the modular hole stay system



Modular hole stay system – split design

The plastic modular hole stay system enables you to create your own customized hole stay quickly and easily. Hole stay inserts are available for Series S 1250 and SX 1250. Available hole diameters: 10, 15, 20, 25, 30, 40, 50. Please do get in touch with us, we would be happy to advise you.

The illustrations on this page show the design principle. The design of individual types can be different.

Types S/SX 0650, 0950, 1250, 1800

Divider system TS 0 without height subdivision

Type	Stay variant	h _i mm	S _T mm	a _T min mm	a _x min mm
S/SX 0650	RS 1/2	31	3	11.5	13
S/SX 0650	RMD	30	3	11.5	13
S/SX 0650	RR	26	4	20.0	25
S/SX 0950	RS 1/2	46	4	12.0	14
S/SX 0950	RM	43	4	10.0	14
S/SX 0950	RMD	44	4	12.0	14
S/SX 0950	RR	42	4	20.0	20
S/SX 1250	RS 1/2	72	5	12.5	15
S/SX 1250	RV	72	6	13.0	16
S/SX 1250	RM	69	5	17.5	20
S/SX 1250	RMD	69	5	17.5	20
S/SX 1250	RR	66	4	30.0	30
S/SX 1800	RM	108	7.5	21.5	25
S/SX 1800	RMD	104	7.5	21.5	25
S/SX 1800	RR	104	5	45.0	45

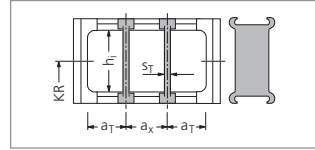

In the standard version, the divider systems are mounted on every second chain link.

The dividers can be moved in the cross section.

S/SX Series

Selection

BASIC LINE

BASIC LINE PLUS

VARIO LINE

TUBE SERIES

3D LINE

STEEL LINE

Inside heights

31
108

Chain widths

70
1000

kabelschlepp.de

Divider system TS 1 with continuous height subdivision made of aluminium

Type	Stay variant	h _i mm	S _T mm	a _T min mm	a _x min mm	S _H mm	h ₁ mm	h ₂ mm	h ₃ mm
S/SX 1250	RV	72	6	13	16	4	15	30	45

The dividers can be moved in the cross section.

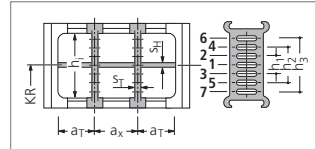

In the standard version, the divider systems are mounted on every second chain link.

Fon: +49 2762 4003-0

Divider system TS 2 with grid subdivision made of aluminium (1 mm grid)

Type	Stay variant	h _i mm	S _T mm	a _T min mm	a _x min mm	S _H mm	h ₁ mm	h ₂ mm	h ₃ mm
S/SX 1250	RV	72	6	13	20	4	15	30	45

The dividers can be moved in the cross section.

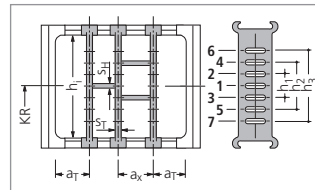

In the standard version, the divider systems are mounted on every second chain link.

OnlineEngineer.de
KABELSCHLEPP
Cable Center Configurator

271

Types S/SX 0650, 0950, 1250, 1800

Divider system TS 3 with section subdivision, partitions made of plastic

Inside heights



Chain widths



Type	Stay variant	h _i mm	S _T mm	a _T min mm	a _x min mm	S _H mm	h ₁ mm	h ₂ mm	h ₃ mm	h ₄ mm	h ₅ mm
S/SX 1800	RM	108	8	11.5	16*	4	14	28	42	56	70

* When using plastic partitions
The dividers are fixed by the partitions, the complete divider system is movable.

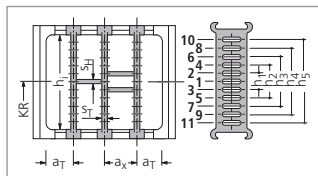

In the standard version, the divider systems are mounted on every second chain link.

Dimensions of the plastic partitions for TS 3

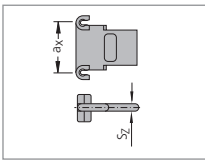

S _z	a _x (center-to-center distance, dividers)									
4	16	18	23	28	32	33	38	43	48	58
	64	68	78	80	88	96	112	128	144	160
	176	192	208	-	-	-	-	-	-	-

Dimensions in mm

Aluminium partitions in 1 mm width sections are also available.

When using **partitions with a_x > 112 mm**, there should be an additional central support with a **twin divider** (S_T = 4 mm).
Twin dividers are designed for subsequent fitting in the partition system.

kabelschlepp.de

Fon: +49 2762 4003-0

Use our free project planning service.

Guide channels
➤ from page 295



Strain relief devices
➤ from page 302



Cables for cable carrier systems
➤ from page 344



Types S/SX 0650, 0950, 1250, 1800

End connectors made of steel (types S) or high-grade steel (types SX)

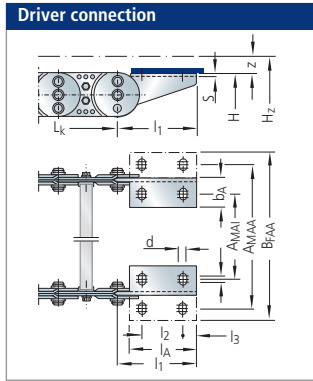
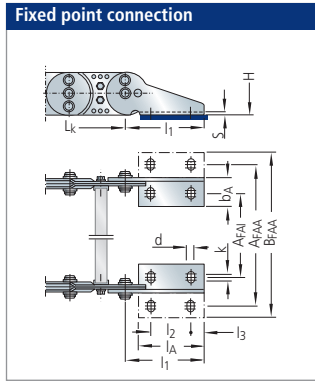

Inside heights



Chain widths

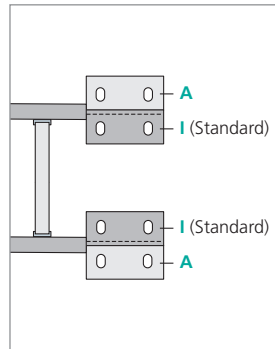
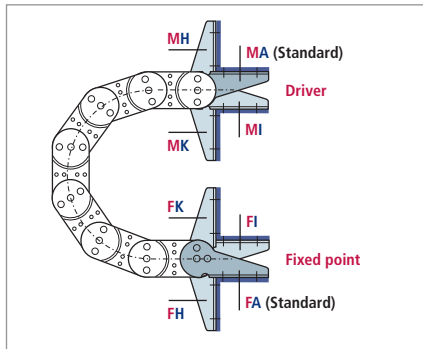

Table of dimensions:

Type	l_1	l_2	l_3	l_A	b_A	d	k	s	A_{FAI}	A_{FAA}	B_{FAA}	A_{MAI}	A_{MAA}	B_{MAA}
S/SX 0650	95	45	15	75	30	6.4	5	3	B _k -37	B _k +25	B _k +51	B _k -43	B _k +19	B _k +45
S/SX 0950	125	65	20	105	55	8.4	10	4	B _k -63	B _k +49	B _k +99	B _k -71	B _k +41	B _k +91
S/SX 1250	155	80	25	130	55	10.5	10	5	B _k -64	B _k +46	B _k +96	B _k -74	B _k +36	B _k +86
S/SX 1800	210	115	30	175	60	13	10	5	B _k -77	B _k +53	B _k +103	B _k -88	B _k +41	B _k +91

Dimensions in mm

Connection variants



Connection point

- M** – Driver
- F** – Fixed point

Connection type

- A** – Threaded joint outside (standard)
- I** – Threaded joint, inside
- H** – Threaded joint, rotated through 90° to the outside
- K** – Threaded joint, rotated through 90° to the inside

Connecting surface

- I** – Connecting surface inside (< B_k)
- A** – Connecting surface outside (> B_k)

On the driver and the fixed point, the connecting surfaces can be mounted on the outside or the inside according to preference.

The connection type can easily be altered at a later date.

In the standard version, the connectors are mounted with the bolting to the outside and the connecting surface to the inside (**FAI/MAI**). When ordering please specify the desired connection type.

kabelschlepp.de

Fon: +49 2762 4003-0

OnlineEngineer.de
KABELSCHLEPP
Cable Center Configurator

Types S/SX 2500 and 3200

- **Type S:**
Chainbands made of galvanized steel
- Type SX:**
Chainbands made of high-grade stainless steel
- **Available in 1 mm width sections**

Inside heights



Chain widths



WIDTH SECTIONS

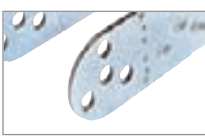

Side plate construction for types S/SX 2500



Side plate construction for types S/SX 3200

Bend radius and pitch

Type	Bend radii KR mm							
S/SX 2500	365	445	600	760	920	1075	1235	1395
S/SX 3200	-	470	670	870	1075	1275	1480	1785

Pitch:
S/SX 2500: t = 250 mm
S/SX 3200: t = 320 mm

Load diagrams

for unsupported length L_f depending on the additional load*

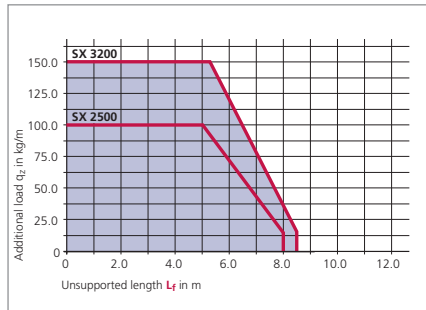
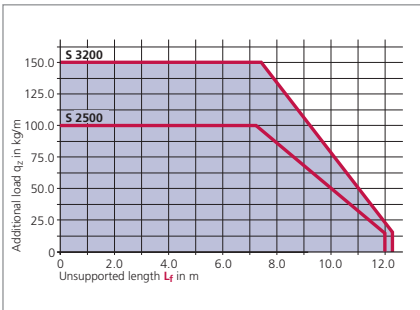

Unsupported length L_f

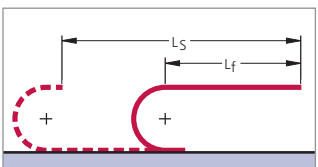

Determining the length of the cable carrier see page 41.

* Load diagrams for medium intrinsic chain weight. The possible additional load for large carrier widths is smaller due to the increased intrinsic chain weight.

Example of ordering

Cable carrier	Divider system	Connection
S 2500 - 850 - LG - 760 - ER 1 - 9250	TS 0 / 4	FA/MA
Type Stay width B_{St} in mm Stay variant Bend radius KR in mm Chain band material Chain length L_k in mm (with-out connection)	Divider system Number of dividers n_T	Connection Fixed point/Driver

Chain band materials: St = Galvanized steel / ER 1 = Stainless steel / ER 1S = Stainless steel, sea water resistant / ER 2 = High-strength stainless steel. Please contact us for further information about the chain band materials.

Ordering divider systems: Please state the designation of the divider system (TS 0, TS 1 ...) and the number of dividers. Possibly attach a sketch with the dimensions.

Fon: +49 2762 4003-0

Use our free project planning service.

Type S/SX 2500

Stay variant RM – frame stay, solid design

- frame stay RM made of aluminium – solid design
- for heavy loads – maximum chain widths possible
- **Standard stay arrangement:** on every 2nd chain link. Stays can be fitted on every chain link, please specify when placing your order.
- bolted stays for maximum stability

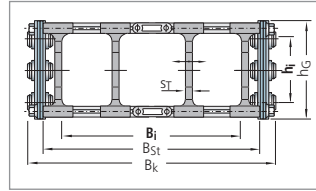

Inside height

183

Chain widths

250 - 1200

Dimensions and intrinsic chain weight

Type	Stay variant	h _i	h _G	B _k min	q _k min	B _k max	q _k max	B _j	B _{St}	WIDTHSECTIONS
S/SX 2500	RM	183	220	250	39	1200	44	B _k – 75	B _j + 43	1 mm

Dimensions in mm/Weights in kg/m

kabelschlepp.de

Standard divider for different separation options



Dividers are available for stay variant RM which enable different height subdivisions of the steel tube to be achieved.

Please do get in touch with us. We would be happy to advise you.

Font: +49 2762 4003-0

Guide channels
➤ from page 295

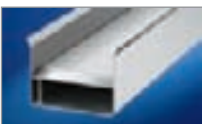

Strain relief devices
➤ from page 302



Cables for cable carrier systems
➤ from page 344



Types S/SX 2500 and 3200

Stay variant LG – hole stay made of aluminium, split design

Inside height
180
220

Chain widths
250
1500

- optimum cable guidance in the neutral bending line is possible
- drilling pattern individually adapted to the application
- high stability due to solid construction
- split design as standard for easy laying of the cables
- **Standard stay arrangement:** on every 2nd chain link. Stays can be fitted on every chain link, please specify when placing your order.
- bolted stays for maximum stability – also available not split

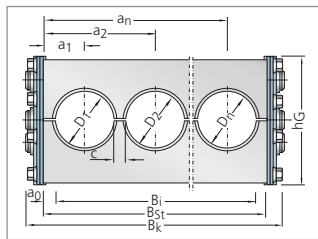
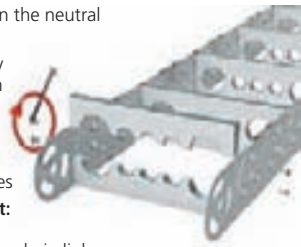

Dimensions and intrinsic chain weight

Type	Stay variant	D max	hG	Bk min	qk min*	Bk max	qk max*	a0 min	Bj	BSt
S/SX 2500	LG	180	220	250	36.5	1200	48.5	22	BSt - 44	Bk - 32
S/SX 3200	LG	220	300	250	57.5	1500	72.5	22	BSt - 44	Bk - 40



* Listed weights assume that the hole area is approx. 50 % of the stay. Dimensions in mm/Weights in kg/m

kabelschlepp.de

Fon: +49 2762 4003-0

Selection of some hole patterns:

Split hole stay with individual holes

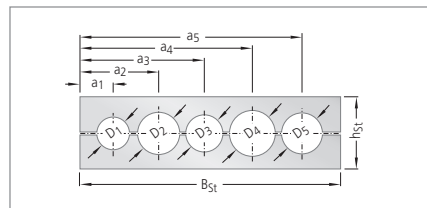

Split hole stay with horizontal and vertical elongated holes*

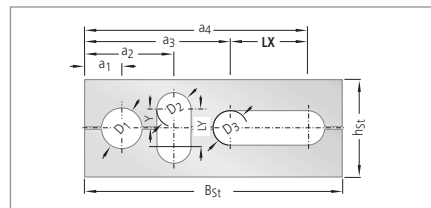

*) With an off-center arrangement of the holes, the cables are subject to a relative movement when the carrier is in motion.

Use our free project planning service.

Guide channels
➤ from page 295



Strain relief devices
➤ from page 302



Cables for cable carrier systems
➤ from page 344



Types S/SX 2500 and 3200

End connectors made of steel (types S) or high-grade steel (types SX)

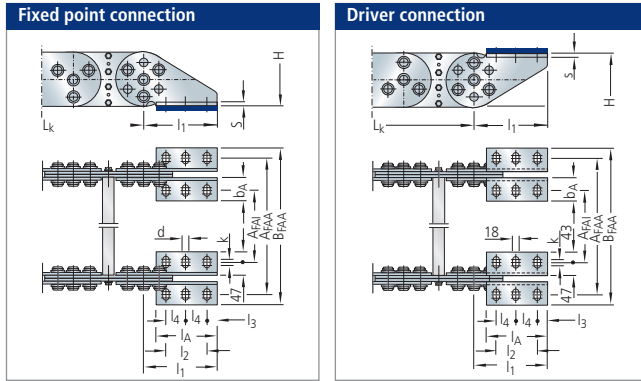

Inside height

180
220

Chain widths

250
1500

Table of dimensions:

Type	l_1	l_2	l_3	l_4	l_A	b_A	d	k	s	A_{FAI}	A_{FAA}	B_{FAA}	A_{MAI}	A_{MAA}	B_{MAA}
S/SX 2500	300	170	40	85	250	90	18	15	6	B_k-126	B_k+74	B_k+160	B_k-126	B_k+74	B_k+160
S/SX 3200	350	200	50	100	300	110	22	20	6	B_k-154	B_k+90	B_k+196	B_k-154	B_k+90	B_k+196

Dimensions in mm

Connection variants

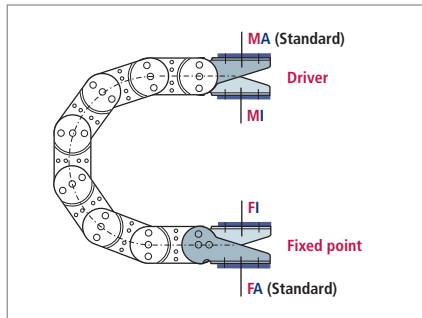

Connection point

- M** – Driver
- F** – Fixed point

Connection type

- A** – Threaded joint outside (standard)
- I** – Threaded joint, inside

In the standard version, the end connectors are mounted with the threaded joint outwards (MA/FA). When ordering please specify the desired connection type (see ordering key on page 338).

Types S/SX 5000, 6000, 7000

- Type S:
Chainbands made of galvanized steel
- Type SX:
Chainbands made of high-grade stainless steel

- Available in 1 mm width sections

Inside heights



Chain widths



Dimensions and intrinsic chain weight

Type	h _i max	h _G	B _k min	B _k max
S/SX 5000	150	200	250	1200
S/SX 6000	240	300	300	1500
S/SX 7000	370	450	350	1800

Larger dimensions and special designs are available on request.

Dimensions in mm

Bend radius and pitch

Type	Bend radii KR mm				
S/SX 5000	500	600	800	1000	1200
S/SX 6000	700	900	1100	1300	1500
S/SX 7000	1100	1250	1500	1800	2400

Pitch:

- S/SX 5000: t = 200 mm
- S/SX 6000: t = 320 mm
- S/SX 7000: t = 450 mm



Types S/SX 5000, 6000, 7000

Load diagram

for unsupported length L_f depending on the additional load

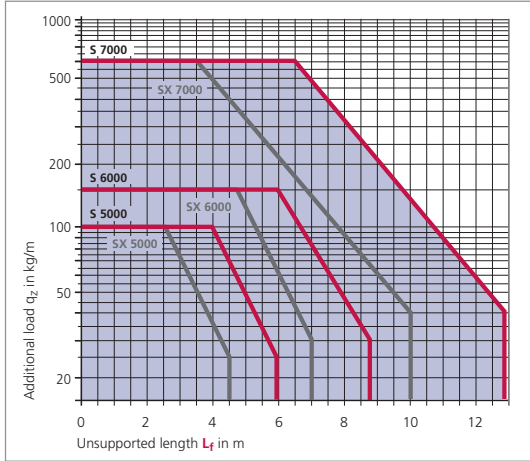

Unsupported length L_f

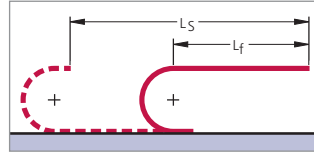

Determining the length of the cable carrier see page 41.



Design and ordering

Please contact us, we would be happy to advise you.

Subject to change.

S/SX Series

Selection

BASIC LINE

BASIC LINEPLUS

VARIO LINE

TUBE SERIES

3D LINE

STEEL LINE

Inside heights

150
370

Chain widths

250
1800

kabelschlepp.de

Font: +49 2762 4003-0

OnlineEngineer.de
Kabelschlepp
Cable Carrier Configurator

Steel band covers

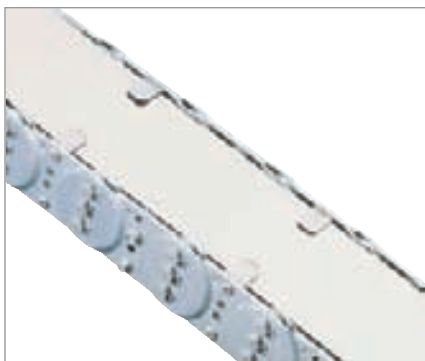

Cable carriers made of rust and acid resistant spring steel strip can be supplied for protection of the cables against flying sparks, radiant heat and small chips.

- Economically priced cover variant for half-stay version
- Made of rust and acid resistant spring band steel
- Maximum steel band width: 1000 mm



kabelschlepp.de

Table of dimensions

Type	Steel band length		Steel band width
	Outside steel band	Inside steel band	
S/SX 0650	$L_k + 280$	$L_k + 130$	$B_k - 22$
S/SX 0950	$L_k + 360$	$L_k + 150$	$B_k - 27$
S/SX 1250	$L_k + 470$	$L_k + 170$	$B_k - 34$
S/SX 1800	$L_k + 640$	$L_k + 200$	$B_k - 40$
S/SX 2500	$L_k + 945$	$L_k + 255$	$B_k - 48$

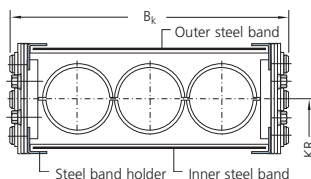

Steel band covers for the other series are available on request!

Dimensions in mm

Fon: +49 2762 4003-0

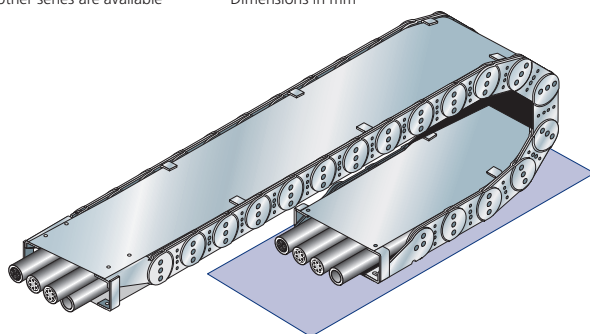

Fastening the steel band



■ Steel band holder on the sidebands.

■ Fastening to the chain connection with special end connector.

Use our free
project planning service.

Support rollers – horizontal arrangement "with support"

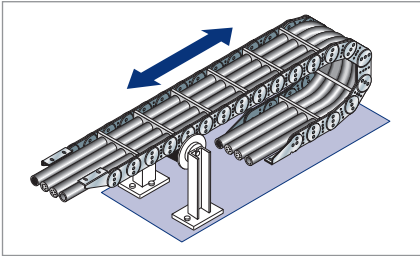

- If the unsupported length of the cable carrier is exceeded, the upper trough can be supported by rollers.
- Instead of using a KABELSCHLEPP cable carrier with supports, we recommend that you use the next size up, provided that the installation conditions allow this.

Arrangement of the support

Arrangement with a support roller:

when $L_S < 3 L_f$ $a_R = \frac{L_S}{6}$

The distance of the support to the fixed point in this arrangement is approx 1/6 of the total travel length!

Schematic illustration

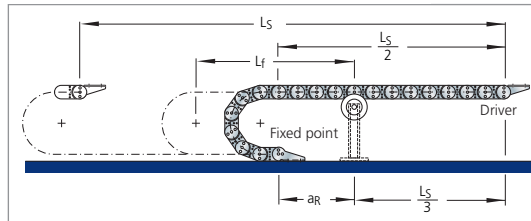

Standard support rollers

for Types LS/LSX 1050, S/SX 0650, 0950, 1250, 1800

- Economically priced standard support rollers in light-weight design
- Long service life due to ball-bearing rollers
- Optimized installation width
- Only for use with two-band chains

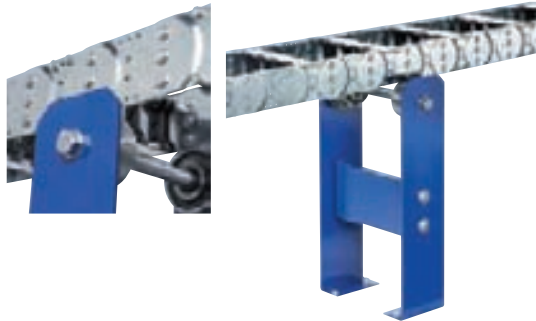

Support rollers with reinforced design

for Types LS/LSX 1050, S/SX 0650, 0950, 1250 and 1800

- Solid design for extreme loads
- Long service life due to ball-bearing roller
- Also suitable for multi-band chains
- With hard manganese wear protection for type S/SX and applications with high loads
- Also available in stainless steel version



CONDUFLEX
connecting the power to innovate



CONDUFLEX

Closed designer cable carrier

- Very well sealed design
- With protective straps ideal for hot chips
- Easy replacement of the brackets where external damage has occurred
- Easy to shorten or extend at a later date
- TÜV type tested in accordance with 2 PFG 1036/10.97

Optional:
Protective straps for protecting the stop grooves against contamination



Different end connectors



Completely enclosed cable carriers in a sophisticated design

Attractive appearance due to stainless steel crossbars and frame made of fiberglass reinforced polyamide

Optimum protection for cables and hoses

Quiet operation due to small pitch

Inside heights



Inside widths



kabelschlepp.de

Fon: +49 2762 4003-0

OnlineEngineer.de
KABELSCHLEPP
Cable Carrier Configurator



CONDUFLEX – Designer cable carrier in use

Types CF 055, 060, 085, 115, 120, 175

■ Closed cable carriers (TUBES)

Inside heights



Inside widths

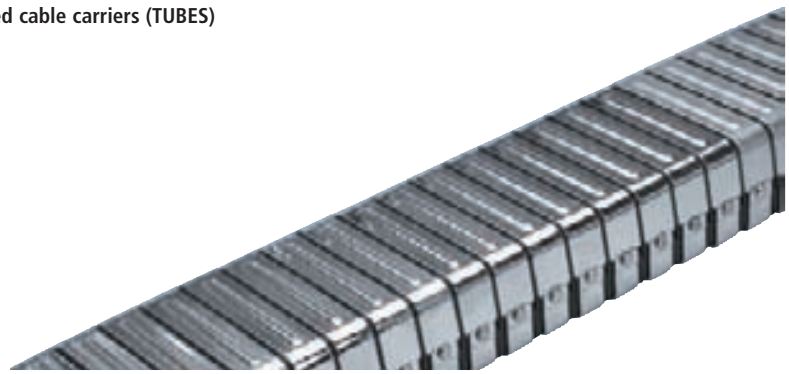

kabelschlepp.de

Type	h_i	B_k	Maximum travel length in m	Dynamics of unsupported arrangement		Page
				Travel speed v_{max} in m/s	Travel acceleration a_{max} in m/s ²	
CF 055	25	45	3.0	10	20	285
CF 060	40	36	3.5	10	20	285
CF 085	38	73	4.0	8	18	285
CF 115	52	102	5.0	8	16	285
CF 120	70	100	5.5	6	15	285
CF 175	72	162	6.0	6	12	285

Dimensions in mm

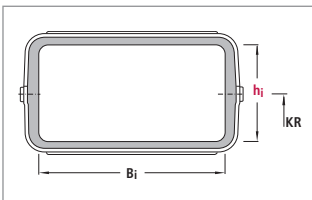

Fon: +49 2762 4003-0

Use our free project planning service.

Example of ordering

Cable carrier	CF 120	-	140	-	1200	Connection	FST/FQF
CONDUFLEX Type	Bend radius KR in mm		Conduit length L_{ES} in mm (without connection)		Connection Fixed point/Driver		

Types CF 055, 060, 085, 115, 120, 175

Dimensions and intrinsic hose weight

Type	h _i mm	h _G mm	B _i mm	B _S mm	Intrinsic hose weight kg/m
CF 055*	25	38	45	62	1.25
CF 060	40	52	36	60	1.60
CF 085*	38	52	73	92	1.90
CF 115*	52	67	102	123	2.60
CF 120	70	86	100	127	3.80
CF 175*	72	94	162	190	5.20

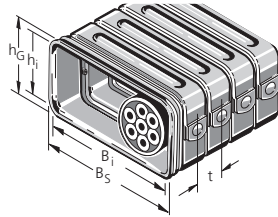

Inside heights

25
-
72

Inside widths

45
-
162

*) KABELSCHLEPP CONDUFLEX TUBES CF 055, CF 085, CF 115 and CF 175 can be fitted with **protective straps**, to shield the impact slots of the plastic frame from contamination.

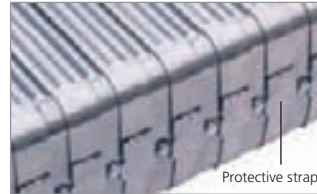

Protective strap

kabelschlepp.de

Bend radius and pitch

Type	Bend radii KR mm			
CF 055	65	100	150	—
CF 060	100	—	—	—
CF 085	100	150	200	250
CF 115	140	225	300	—
CF 120	155	200	—	—
CF 175	185	250	350	—

Pitch:

Typ CF 055: t = 20 mm

Typ CF 060: t = 20 mm

Typ CF 085: t = 20 mm

Typ CF 115: t = 25 mm

Typ CF 120: t = 25 mm

Typ CF 175: t = 30 mm

Font: +49 2762 4003-0

Load diagram

for unsupported length L_f depending on the additional load

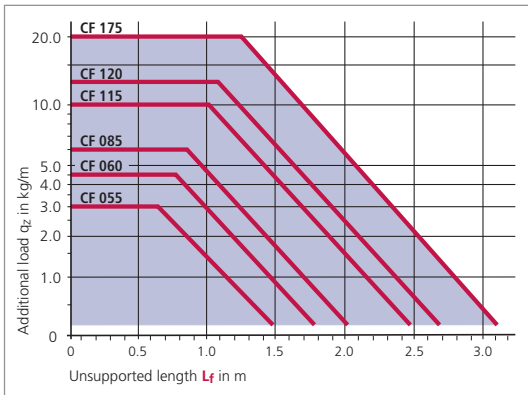

Unsupported length L_f

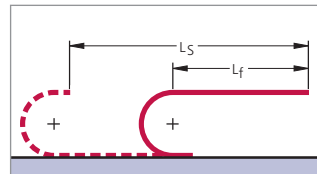

OnlineEngineer.de
KABELSCHLEPP
Cable Carrier Configurator

Types CF 055, 060, 085, 115, 120, 175

Connection dimensions

Inside heights



Inside widths



Diagonal flange connector – SF

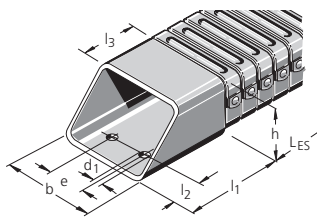

CONDUFLEX Type	b	h	e	d ₁	l ₁	l ₂	l ₃
CF 055	55	36	22	6.5	44	12.5	20
CF 060	55	52	22	6.5	44	12.5	20
CF 085	85	50	50	6.5	70	15.0	32
CF 115	117	66	70	8.5	84	17.5	34
CF 120	120	84	70	8.5	82	17.5	48
CF 175	182	92	100	10.5	100	22.5	45

Dimensions in mm

Connection variants for diagonal flange connectors SF

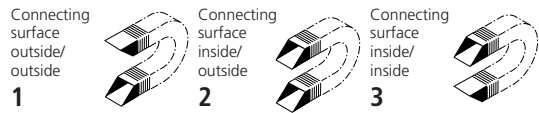

Please state the position of the connecting surfaces when ordering.

Standard connector bracket – ST

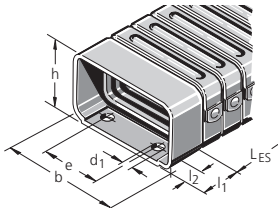

CONDUFLEX Type	b	h	e	d ₁	l ₁	l ₂
CF 055	55	36	22	6.5	20	8.5
CF 060	–	–	–	–	–	–
CF 085	85	52	50	6.5	25	10.0
CF 115	116	68	65-70	8.5	35	10.0
CF 120	120	84	70	8.5	35	12.5
CF 175	182	92	100	10.5	40	15.0

Dimensions in mm

Connection variants for standard flange connectors ST

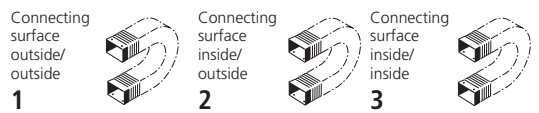

Please state the position of the connecting surfaces when ordering.

Types CF 055, 060, 085, 115, 120, 175

Connection dimensions

Cross flange connector bracket – QF

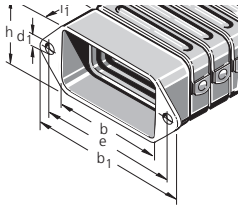

CONDUFLEX Type	b	h	b ₁	e	d ₁	l ₁
CF 055	55	35	90	75	6.5	20
CF 060	–	–	–	–	–	–
CF 085	85	50	120	105	6.5	25
CF 115	116	64	160	140	8.5	35
CF 120	–	–	–	–	–	–
CF 175	182	90	226	200	10.5	40

Dimensions in mm

Inside heights



Inside widths



High flange bracket – HF

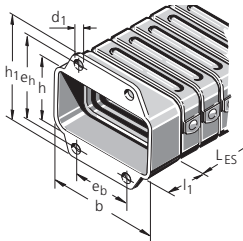

CONDUFLEX Type	b	h	h ₁	e _b	e _h	d ₁	l ₁
CF 055	55	35	70	18	55	6.5	20
CF 060	–	–	–	–	–	–	–
CF 085	85	50	85	45	70	6.5	25
CF 115	116	64	110	60	90	8.5	35
CF 120	–	–	–	–	–	–	–
CF 175	182	90	136	95	110	10.5	40

Dimensions in mm

The connectors SF, ST, QF and HF can be combined. Please state when ordering.

kabelschlepp.de

Fon: +49 2762 4003-0

OnlineEngineer.de
 with KABELSCHLEPP
 Cable Carrier Configurator

MOBIFLEX
connecting the power to innovate



MOBIFLEX

Enclosed cable carrier with flexible metal helical tube

- Very well sealed design
- Ideal in case of hot metal chips
- Unsupported thanks to the inserted, pre-tensioned steel band

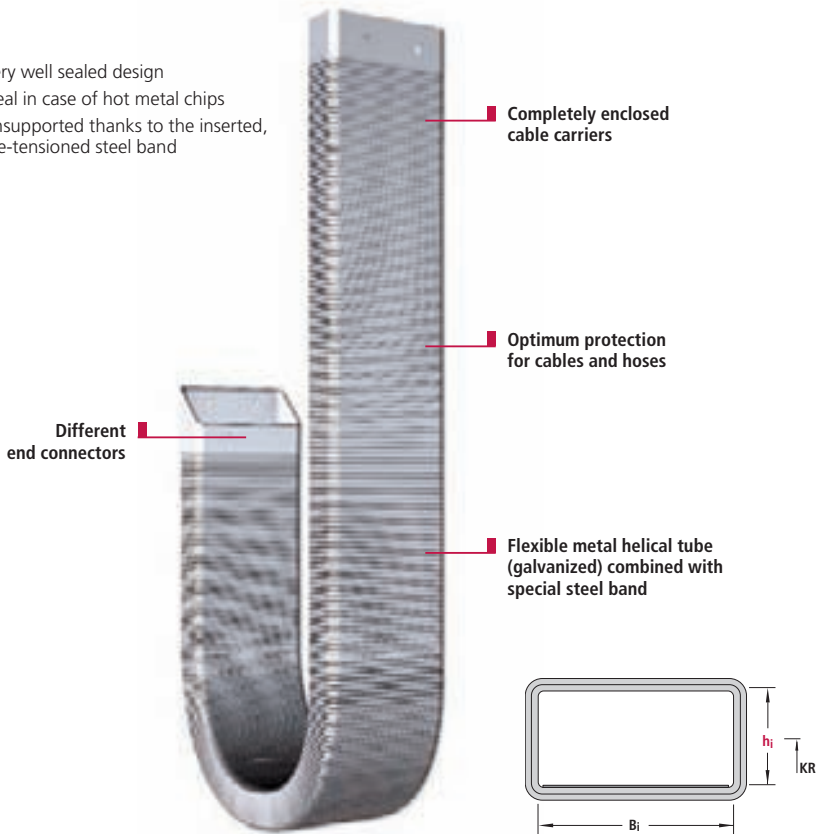

Different end connectors

Completely enclosed cable carriers

Optimum protection for cables and hoses

Flexible metal helical tube (galvanized) combined with special steel band

MOBIFLEX

Inside heights



Inside widths



kabelschlepp.de

Fon: +49 2762 4003-0

Type	h _i	B _k	Maximum travel length in m	Dynamics of unsupported arrangement		Page
				Travel speed v _{max} in m/s	Travel acceleration a _{max} in m/s ²	
MF 030.1	24	26	2.0	10	20	290
MF 050.1	24	45	3.0	10	20	290
MF 050.2	44	45	3.0	10	20	290
MF 080.1	40	80	3.5	10	18	290
MF 080.2	54	80	3.5	10	18	290
MF 080.3	78	80	3.5	10	18	290
MF 110.1	53	109	4.0	6	15	290
MF 110.2	73	109	4.0	6	15	290
MF 110.3	108	109	4.0	6	15	290
MF 170.1	72	170	5.0	6	12	290
MF 170.2	102	170	5.0	6	12	290
MF 170.3	167	170	5.0	6	12	290

Subject to change.

Dimensions in mm

OnlineEngineer.de
KABELSCHLEPP
Cable Carrier Configurator

Types MF 030, 050, 080, 110, 170

Dimensions, intrinsic weight and bend radius

Inside heights



Inside widths



MOBIFLEX Type	B _S	B _I	h _G	h _I	Available bend radii KR			Weight G _S	Shortening L _{VK}
MF 030.1	30	26	30	24	80	-	-	1.2	45
MF 050.1	50	45	30	24	75	100	150	2.0	45
MF 050.2	50	45	50	44	110	150	200	2.5	80
MF 080.1	85	80	45	40	100	150	200	3.0	70
MF 080.2	85	80	60	54	150	200	250	3.5	95
MF 080.3	85	80	85	78	200	-	-	5.1	135
MF 110.1	115	109	60	53	150	200	250	4.8	95
MF 110.2	115	109	80	73	200	250	350	5.3	125
MF 110.3	115	109	115	108	300	-	-	6.6	180
MF 170.1	175	170	80	72	190	250	300	7.2	125
MF 170.2	175	170	110	102	250	300	400	8.2	175
MF 170.3	175	170	175	167	365	-	-	9.2	275

Stated bend radii = KR_{max}

Dimensions in mm / Weight in kg/m

Tolerances specified by manufacturer: -20 to -30 mm

kabelschlepp.de

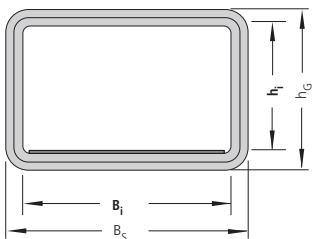

Hose length (with loop):
 $L_{ES} \approx \frac{L_S}{2} + L_B$

Bend length
 $L_B = KR \cdot \pi + \text{Reserve (KR)}$

Stretched hose length:
 $L_{gestr.} = L_{ES} - L_{VK}$

Hose shortening
 $L_{VK} = h_G/2 \cdot \pi$

Load diagram

for unsupported length L_f depending on the additional load

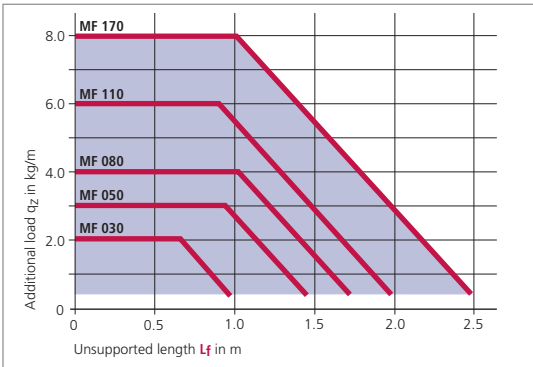

Unsupported length L_f

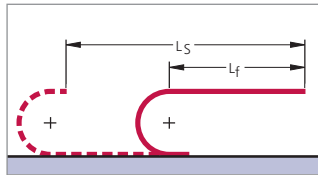

Fon: +49 2762 4003-0
 Use our free project planning service.

Example of ordering

Cable carrier	Connection
MF 170.1 - 250 - 980	FST/FQF
MOBIFLEX Type	Connection Fixed point/Driver
Bend radius KR in mm	
Conduit length L _S in mm (without connection)	

Types MF 030, 050, 080, 110, 170

Connection dimensions

Diagonal flange connector – SF

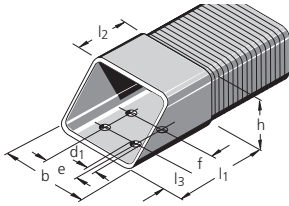

Type	b	h	e	f	d	l ₁	l ₂	l ₃
MF 030.1	34	34	–	40	9	120	60	10
MF 050.1	54	34	20	40	9	120	60	10
MF 050.2	54	54	20	40	9	120	60	10
MF 080.1	90	50	50	40	9	120	60	10
MF 080.2	90	65	50	40	9	120	60	10
MF 080.3	90	90	50	40	9	120	60	10
MF 110.1	120	65	80	40	9	120	60	10
MF 110.2	120	85	80	40	9	120	60	10
MF 110.3	120	120	80	40	9	120	60	10
MF 170.1	180	85	140	40	9	120	60	10
MF 170.2	180	115	140	40	9	120	60	10
MF 170.3	180	180	140	40	9	120	60	10

Dimensions in mm

Inside heights



Inside widths



Connection variants for diagonal flange connectors SF

Connecting surface outside/outside

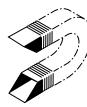

1

Connecting surface inside/outside

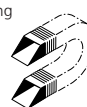

2

Connecting surface inside/inside

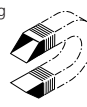

3

Please state the position of the connecting surfaces when ordering.

Standard connector bracket – ST

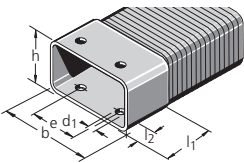

Type	b	h	e	e _b	e _n	d	l ₁	l ₂	b _w	b ₁	h ₁
MF 030.1	34	34	–	56	56	9	60	20	20	74	74
MF 050.1	54	34	20	76	56	9	60	20	20	94	74
MF 050.2	54	54	20	76	76	9	60	20	20	94	94
MF 080.1	89	49	50	111	71	9	75	20	20	129	89
MF 080.2	89	64	50	111	86	9	75	20	20	129	104
MF 080.3	89	89	50	111	111	9	75	20	20	129	129
MF 110.1	119	64	80	141	86	9	95	20	20	159	104
MF 110.2	119	84	80	141	106	9	95	20	20	159	124
MF 110.3	119	119	80	141	141	9	95	20	20	159	159
MF 170.1	179	84	140	201	106	9	95	20	20	219	124
MF 170.2	179	114	140	201	136	9	95	20	20	219	154
MF 170.3	179	179	140	201	201	9	95	20	20	219	219

Dimensions in mm

Cross flange connector bracket – QF

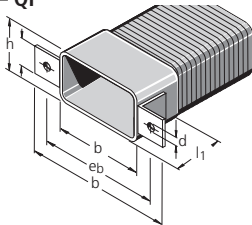

High flange bracket – HF

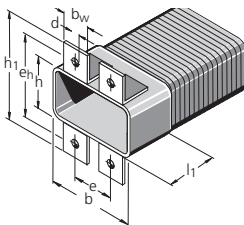

Front flange connectors can be supplied in accordance with customer drawings.

kabelschlepp.de

Fon: +49 2762 4003-0

OnlineEngineer.de
Web-Configurator
 Cable Carrier Configurator



Accessories for cable carriers



Support trays

page 294

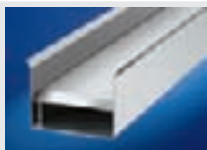

Guide channels

page 295



**RCC – Rail Cable Carrier
ECC – Emergency Cable Carrier**

page 299



Strain relief devices

page 301



Assembly profile bars

page 307

Support trays

A flat surface is required for the safe operation of the cable carrier. If this is not available on site, a support tray must be provided.

The standard supply length is 2 m. Special lengths are available on request.



kabelschlepp.de

Single-part design

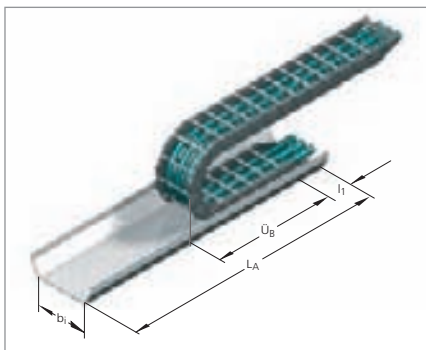

Materials: Galvanized steel plate
Stainless steel plate
Aluminium plate



Should you require a support tray in a split design, please contact us. We would be happy to advise you.

Inside width (with standard connection)

$$b_1 \text{ min} \approx B_k + 15 \text{ mm}$$

Length (with standard connection)

$$L_A = \frac{L_c}{2} + \ddot{U}_B + l_1$$

\ddot{U}_B – loop overhang
 l_1 – connection length

Where there is a strain relief device at the fixed point, the length of the support tray must be increased accordingly.

Use our free
project planning service.

Fon:

+49 2762 4003-0

Guide channels

In the case of long travel lengths the upper trough of the cable carrier **glides** on its lower trough. Beyond the fixed point the cable carrier glides on the sliding surface (support) of the guide channel. The guide channels prevent the upper trough from slipping off the lower trough and ensure quiet, low-wear operation.

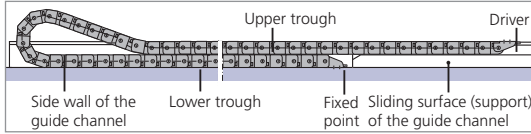

The economical solution: We recommend that the fixed point be placed in the middle of the travel length (central feed). This will result in the shortest lengths for the cable carrier, cables and guide channel.



One-sided cable carrier arrangement (standard connection)

$$L_{KA} = L_S + L_{Z1} + L_{Z2}$$

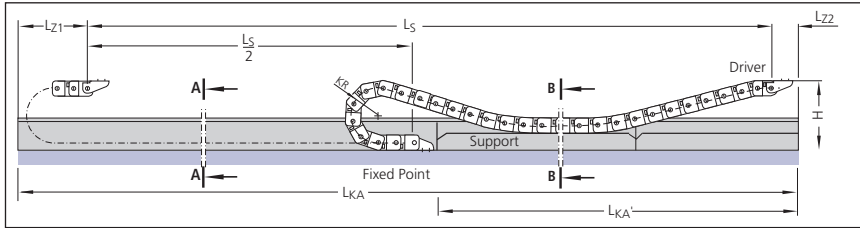

Opposing cable carrier arrangement (standard connections)

$$L_{KA} = L_S + 2 L_{Z1} + X$$

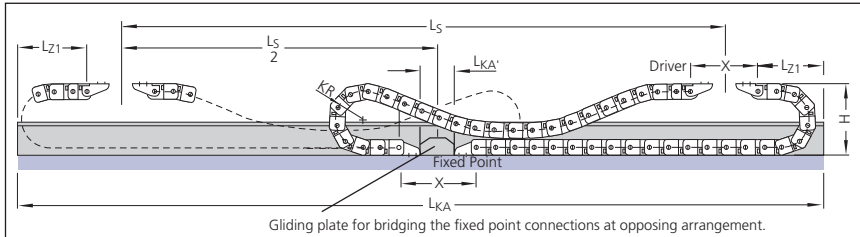

Explanation of terms – guide channels

- L_S = Travel length of cable carrier
- L_{KA} = Channel length
- L_{KA}' = Channel length with support
 - ($\triangleq L_S/2$) with one-sided arrangement
 - ($\triangleq X - 2 l_1$) with opposing arrangement
- L_{Z1} = Additional measurement for loop overhang
 - ($\triangleq \ddot{U}_B + 50 \text{ mm}$) with standard connection
- L_{Z2} = Additional measurement for connection
 - ($\triangleq l_1 + 50 \text{ mm}$)
- X = Connection distance with an opposing arrangement

Depending on the chain size, the channel inner width is 4-5 mm greater than the width of the guided cable carrier. Depending on the length of travel, the cable carrier connection heights should be reduced.

Do get in touch with us! We would be happy to calculate the dimensions of the guide channel to suit your application.

Guide channels made of steel plate – standard design

We also manufacture guide channels made of steel plate, customized for your application. In so doing, we can accommodate almost any wish as far as the special shape and fastening options are concerned. To reduce the gliding resistance and wear between the cable carrier and support, a special gliding plate can be glued on. We recommend the use of special gliding plates at speeds > 0.5 m/s and with frequent travel cycles.

- very easy and universal assembly – there is no alignment of the channel side walls with each other as there are no loose channel side walls
- large support widths due to stable U construction
- easy fixing options:
 - standard retaining plates
 - direct welding on-site
 - various special solutions with retaining bracket
- optionally as corrosion-resistant, sea water resistant version

Optional standard fixing with retaining plates

A retaining plate is mounted on the adjoining points and as well as fixing the channel to the floor also guarantees an exact connection of the adjoining points.

- optimum alignment of the adjoining points
- reduced installation times
- minimal number of threaded connections
- secure hold, also in harsh conditions

Please state the channel system when ordering if retaining plates will be needed.

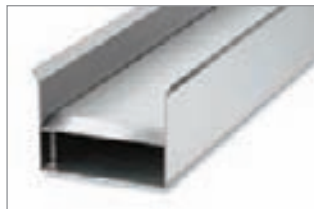

Materials: Galvanized steel plate/
stainless steel

Delivery length: Standard length 2 m/
special lengths on request

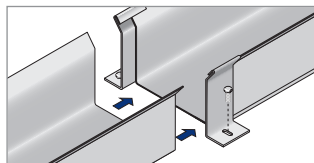

Examples of guide channels special solutions in steel plate design

Bottom open channel

- for fine-grain dirt particles, water, etc. ...
- dust and dirt can drop through the open design below
- application area in washing plants, the woodworking industry, composting plants ...

With KABELSCHLEPP guide channels, you have various different options for fixing them to the ground or on a support structure as well as the standard fixing. Also here, no adjoining point offset of the individual channel elements must occur at the connection points, i.e. sidewalls and floor must form a smooth surface.

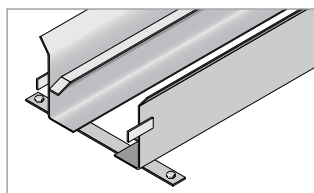

Welded-on fixing plates

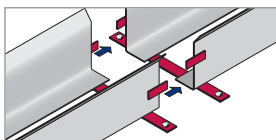

- very easy and universal assembly – there is no alignment of the channel side walls with each other as there are no loose channel side walls
- optimum alignment of the adjoining points
- reduced installation times
- minimal number of threaded connections
- plug-in system

Unsupported connection points

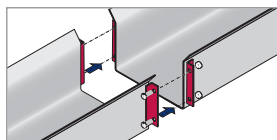

- unsupported adjoining points without support (self-supporting) using flange connections
- secure, fixed connection to adjoining points also for extreme vibrations or in unsupported channel arrangements.

Fixing with fixing brackets

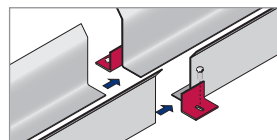

- easy alignment of the adjoining points
- reduced installation times
- minimized number of threaded connections

Modular guide channels made of steel or aluminium

- Simple exchange of individual channel segments even in channel systems which are already installed
- Torsion-resistant channel side walls owing to optimized shaping
- U-shaped profiled beveling (steel)
- Hollow profile bars (aluminium)
- Fastening on C-rails or directly on the mounting surface
- Fixators for balancing the height-tolerances of the mounting surface
- Both systems with anti-climbing protection as an option
- Can be supplied with a continuous floor plate if required.
- Highly resistant to sea-water and corrosion (aluminium and high-grade steel)
- Level, smooth, inner surface
- High-quality design



Simple fixing and alignment of the channel side walls with channel holders: For this purpose, the channel side walls are simply inserted into the channel holder and fixed.



- Simple exchange of individual channel segments with an installed channel system

Examples of fastening options



Direct bolting to the floor



Fastening on C-rails

- Simple horizontal alignment



Fastening by means of fixators

- PA (plastic) fixators as an alignment aid
- Height-balancing is possible thanks to the wedge shape
- Elongated holes in the fixators for balancing horizontal tolerances of mounting-holes



Modular guide channel system made of aluminium profile bars

- Simple installation
- No joint bolting, simple alignment via double clamp connection with plastic clamping profiles.
- Can be supplied with a continuous floor plate if required.
- Easy handling
- Low intrinsic weight
- Single-part channel side walls
- Channel side wall profiles with support with bevels on both sides



Standard lengths

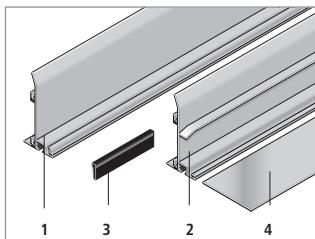

- Part 1** channel side wall profile bar without support 1000 mm + 2000 mm
- Part 2** channel side wall profile bar with support 1000 mm + 2000 mm
- Part 3** plastic clamping profile 130 mm
- Part 4** floor plate – available on request

Examples of fastening options



Screwed on from the "outside"
Fastening screws are used for this purpose. A marking groove simplifies the alignment and drilling.



Screwed on from the "inside"
Recesses are provided in the channel profiles to accommodate hexagonal screws. The screws can be pushed along to the required place.

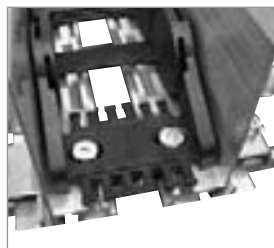

Attached with a clamp
Simple alignment with assembly on a C-Rail.

Rail Cable Carrier – RCC

500 m travel length and more without sag

RCC
KABELSCHLEPP
Rail Cable Carrier



■ Rail Cable Carrier with proven cable and hose carrier MC 1250.

90%

less push/pull forces
in comparison with
gliding arrangement

For extremely long travel lengths

Rolling instead of gliding – the proven principle for less friction.

Due to the substantial friction, it is nearly impossible to realise travel lengths greater than 200 m. With the rail cable carrier, the upper trough does not glide on the bottom trough, it glides on guide rails. Rollers are mounted on ball bearings at the side of the carrier. The guide rails come in the standard connection height. The carrier does not sag. The **tension and thrust is 90% less** in comparison to gliding arrangements.

Quiet and low-vibration operation

The rollers run on the guide rail and do not contact other rollers. Ball bearings and a polyurethane roller surface additionally contribute to quite and smooth operation.

Rail Cable Carrier

- suitable for very long travel lengths
- 90 % less tension and thrust than with a gliding arrangement, thus requiring substantially less driving power
- low-noise and low-vibration operation
- less space required and cost-optimised with a shorter loop overhang – minimum turnaround length
- no impacting of the rollers against one another
- long service life – low maintenance
- minimum stress on the cable and hose carrier and cables
- less push/pull forces
- high travel speeds up to 10 m/s possible
- possible additional load (cable weight) of more than 50 kg/m
- use of proven standard cable carriers
- the carrier cannot climb



Subject to change.

Accessories

Selection

BASIC LINE

BASIC LINEPLUS

VARIO LINE

TUBE SERIES

3D LINE

STEEL LINE

Accessories

kabelschlepp.de

Font:
+49 2762 4003-0

OnlineEngineer.de
KABELSCHLEPP
Cable Carrier Configurator

ECC – Emergency Cable Carrier



Safety for long travel lengths

Blockages in the travel lengths of cable carriers in large systems can destroy the entire cable carrier system. This results in high costs and downtime for the entire system. The **ECC – Emergency Cable Carrier minimizes downtimes and avoids repair costs.**

The **Emergency Cable Carrier System with additional emergency stop system** has been developed especially for systems with long travel lengths.

In applications in harsh environmental conditions it often happens that an object gets into the travel length of the carrier and blocks it. What is needed here is a system that detects such blockages and switches the system off. However, in large systems the moving mass is very large, which means that the moving unit continues to move for several meters even after braking is initiated. This leads to defects in the carrier, a complete failure of the system and extensive repair work. Our decoupling system for cable carriers offers, in addition to the emergency stop function, also a **bridging safeguard for the braking distance.**

Possible areas of application: all applications with long travel lengths, e.g.: crane, port, compost or coal conveyor systems, steel works and raw materials systems.



■ Emergency Cable Carrier on a Rail Cable Carrier. The system can also be adapted for gliding arrangements.

Fon: +49 2762 4003-0

Emergency Cable Carrier System – a possible installation situation



Cable carrier with emergency system – cable routing.

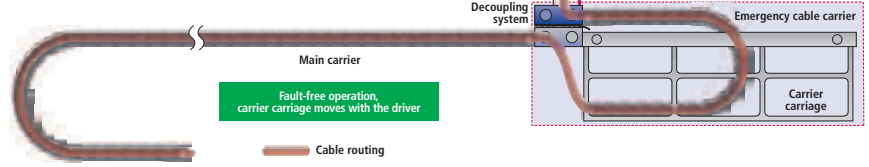

Use our free project planning service.

Decoupling system with automatic emergency cutout

Our Emergency Cable Carrier System offers, in addition to a bridging safeguard for the braking distance with an emergency carrier also an integrated emergency stop system.

The system is switched off if the preset maximum force on the driver of the main cable carrier is exceeded.

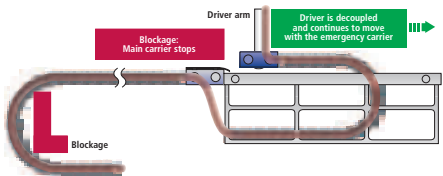

Strain relief devices

The strain relief of the cables depends on the type of cable, the length of the cable carrier and the installation position.

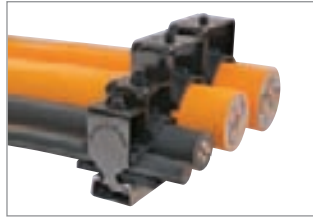

In the case of cable carriers with upper and lower trough sliding on each other (installation variant EBV 05), the installation height of the strain relief must not be higher than the chain link height.

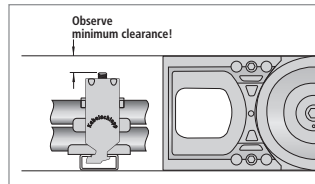

Overview strain relief elements

LineFix saddle-type clamps

- optimized base geometry for secure seating in C-rail
- for one cable and two or three cables on top of each other
- for C-rails with a slot width of 11 mm

See page 302.



Saddle-type clamps Type B

- for C-rails with a slot width of 16 – 17 mm

See page 303.



Strain relief comb strips

- higher fixing force than with a one-sided strain relief comb
- equal power transmission for both pulling and pushing

See page 304.



SZL strain relief devices

- gentle on the cable due to large surface area for enclosing the cables
- simple installation without tools

See page 305.



Block clamps



- for strain relief of hoses

See page 306.

LineFix saddle-type clamps

- for C-rails with a slot width of 11 mm
- for one, two or three cables on top of each other
- optimized base geometry for secure seating in the C-profile
- high quality corrosion protection of the coated housing through cathode immersion painting
- pan design with retaining ribs for secure fixing of the cables
- rounded design of the pan elements is gentle on the cables
- also available in stainless steel version



LineFix Type	Designation	Material no. for a complete LineFix	Material no. for a complete LineFix stainless steel	Min. cable Ø	Max. cable Ø	Number of cables	Width	Total height with max. cable Ø incl. C-rail*
 <p>Single clamps</p>	LF 12-1	13630	13731	6	12	1	16	55
	LF 14-1	13631	13732	12	14	1	18	52
	LF 16-1	13632	13733	14	16	1	20	54
	LF 18-1	13633	13734	16	18	1	22	56
	LF 20-1	13634	13735	18	20	1	24	59
	LF 22-1	13635	13736	20	22	1	26	61
	LF 26-1	13636	13737	22	26	1	30	70
	LF 30-1	13637	13738	26	30	1	34	74
	LF 34-1	13638	13739	30	34	1	38	78
	LF 38-1	13639	13740	34	38	1	42	82
LF 42-1	13640	13741	38	42	1	46	91	
 <p>Double clamps</p>	LF 12-2	13641	13742	6	12	2	16	73
	LF 14-2	13642	13743	12	14	2	18	74
	LF 16-2	13643	13744	14	16	2	20	82
	LF 18-2	13644	13745	16	18	2	22	86
	LF 20-2	13645	13746	18	20	2	24	91
	LF 22-2	13646	13747	20	22	2	26	95
	LF 26-2	13647	13748	22	26	2	30	108
	LF 30-2	13648	13749	26	30	2	34	121
LF 34-2	13649	13750	30	34	2	38	129	
 <p>Triple clamps</p>	LF 12-3	13650	13751	6	12	3	16	98
	LF 14-3	13651	13752	12	14	3	18	98
	LF 16-3	13652	13753	14	16	3	20	105
	LF 18-3	13653	13754	16	18	3	22	111
	LF 20-3	13654	13755	18	20	3	24	118
	LF 22-3	13655	13756	20	22	3	26	130

* Material No.: 3934

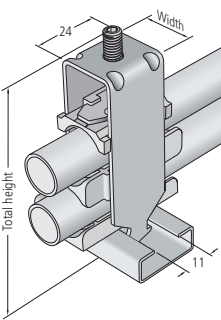

The total height specification is an approximate value. The actual height depends on the diameter and characteristics of the cables, among other things.

Secure seating and easy assembly.

The retaining lug fixes the base securely in the C-profile in the screwed-on state and prevents the clamp from rocking out in case of tensile and compressive loads, regardless of the installation direction.

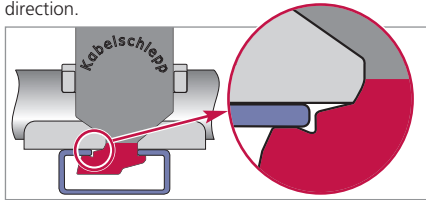

Use our free project planning service.

Fon: +49 2762 4003-0

kabelschlepp.de

Saddle-type clamps Type B

Saddle-type clamps with a large base

For all common commercial C-Profiles with a slot width of 16 – 17 mm

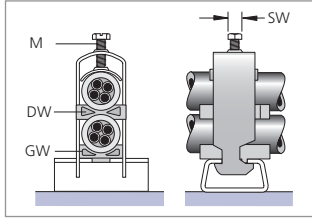

Single clamps for one cable

Type	Cable-Ø	Opposite sleeve GW	Double sleeve DW
B 12	6 – 12	GW 12	–
B 14	10 – 14	GW 14	–
B 16	12 – 16	GW 16	–
B 18	14 – 18	GW 18	–
B 22	18 – 22	GW 22	–
B 26	22 – 26	GW 26	–
B 30	26 – 30	GW 30	–
B 34	30 – 34	GW 34	–
B 38	34 – 38	GW 38	–
B 42	38 – 42	GW 42	–
B 46	42 – 46	GW 46	–
B 50	46 – 50	GW 45	–

Dimensions in mm

Double clamps for two cables, one above the other

Type	Cable-Ø	Opposite sleeve GW	Double sleeve DW
B 12/2	6 – 12	GW 12	DW 12
B 14/2	10 – 14	GW 14	DW 14
B 16/2	12 – 16	GW 16	DW 16
B 18/2	14 – 18	GW 18	DW 18
B 22/2	18 – 22	GW 22	DW 22
B 26/2	24 – 26	GW 22	DW 26
B 30/2	28 – 30	GW 22	DW 30
B 34/2	32 – 34	GW 22	DW 34
B 38/2	36 – 38	GW 22	DW 38
B 42/2	40 – 42	GW 22	DW 42

Dimensions in mm

Triple clamps for three cables one above another

Type	Cable-Ø	Opposite sleeve GW	Double sleeve DW
B 12/3	12	GW 12	DW 12
B 14/3	14	GW 14	DW 14
B 16/3	16	GW 16	DW 16
B 18/3	18	GW 18	DW 18
B 22/3	22	GW 22	DW 22
B 26/3	26	GW 26	DW 26
B 30/3	30	GW 30	DW 30

Dimensions in mm

kabelschlepp.de

Font: +49 2762 4003-0

OnlineEngineer.de
with Cable
 Concepts
 Cable Center Configurator

Strain relief comb strips

For separate strain relief or fastening the cables outside the cable carrier – suitable for all cable and hose carriers.

The strain relief combs have rows of teeth on both sides. So every cable can be fixed securely with two cable binders.

Rows of teeth on both sides for fixing cables

- secure fixing with two or four cable binders
- higher fixing force than for strain relief comb on one side
- even tensile and thrust force transmission
- minimized cable movement

Strain relief comb with C-profile connectors



Ident-No.	b ₁ mm	b ₄ mm	No. of teeth
53654	54	21	3
53655	79	46	5
53656	104	71	7
57320	119	86.5	8
53657	129	96	9
53658	154	121	11
76555	179	146	13
76556	204	171	15
57321	229	196	17
57322	254	221	19

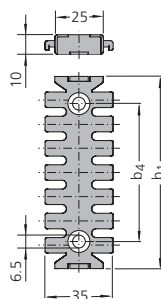

kabelschlepp.de

Strain relief comb



Ident-No.	b ₁ mm	b ₂ mm	b ₃ mm	No. of teeth
52480	50	53	14	3
52485	65	53	14	4
52490	70	70	20	4

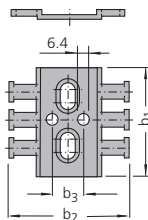

Fon: +49 2762 4003-0

Ident-No.	b ₁ mm	b ₂ mm	b ₄ mm	No. of teeth
52481	70	53	15	4
52482	90	53	35	6
52483	115	53	60	8
52484	142	53	87	10
52486	90	53	25	6
52487	115	53	50	8
52488	140	53	75	10
52489	165	53	100	12
52491	95	70	20	6
52492	120	70	40	8
52493	145	70	65	10
52494	170	70	90	12
52495	195	70	115	14
52496	220	70	140	16
52497	245	70	165	18
52498	270	70	190	20

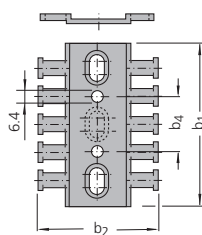

Use our free
project planning service.

SZL strain relief devices

- economically priced
- installation – easy, fast and without tools
- gentle on cables due to large surface area contact with the cables
- small installation height
- without screws and cable binders
- defined contact pressure exerted by spring clamps
- suitable for common commercially available support rails
- immune to vibration
- long service life for dynamic applications
- can also be used as strain relief in switch cabinets



Available sizes

Type	Ident-No.	For cable-Ø	Width B at		Height H
			Ø min	Ø max	
SZL 8	24989	> 5.0 - 8.0 mm	16	16	28
SZL 10	24990	> 8.0 - 10.5 mm	20	20	30
SZL 14	24991	>10.5 - 14.5 mm	23	26	35
SZL 18	24992	>14.5 - 18.0 mm	25	32	40
SZL 22	24993	>18.0 - 22.0 mm	30	36	44
SZL 27	24994	>22.0 - 27.0 mm	34	39	50
SZL 32	24995	>27.0 - 32.0 mm	39	44	56

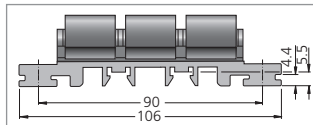
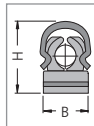

Dimensions in mm

Fixing options



1. By clipping into C-Profiles.
2. By clipping onto cap bar.
3. By pushing into two C-Profile bars.
4. By directly screwing.

Solutions 3 and 4 make the transmission of large tensile forces possible and are therefore recommended as standard solutions.

Installation of the SZL strain relief device



Block clamps

- for strain relief of hoses
- with clamping bolt(s) and mounting rail nut(s)



Single clamps – one cable

Type BS 0

Type	For cable Ø	Height H _{Sch}	Width B _{Sch}	Bolts M6 – DIN 6912		Item-No.
				Number	Length	
BS 0.06	6 - 7 mm	26	28	1	35	16701
BS 0.07	7 - 8 mm	26	28	1	35	16702
BS 0.08	8 - 9 mm	26	28	1	35	16703
BS 0.09	9 - 10 mm	26	28	1	35	16704
BS 0.10	10 - 12 mm	26	28	1	35	16705

Other sizes and designs available on request!

Dimensions in mm

Type BS 0...

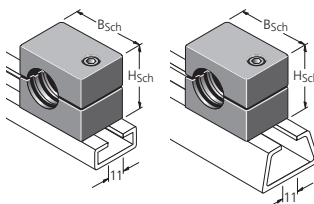

Assembly profile bars:

Material: Steel
Item-No.: 3931

Material: Steel
Item-No.: 3934

Type BS 1 – BS 5

Type	For cable Ø	Height H _{Sch}	Width B _{Sch}	Bolts M6 – DIN 6912		Item-No.
				Number	Length	
BS 1.06	6 - 7 mm	26	34	2	35	16706
BS 1.07	7 - 8 mm	26	34	2	35	16707
BS 1.08	8 - 9 mm	26	34	2	35	16708
BS 1.09	9 - 10 mm	26	34	2	35	16709
BS 1.10	10 - 11 mm	26	34	2	35	16710
BS 1.12	12 - 14 mm	26	34	2	35	16711
BS 2.14	14 - 16 mm	32	40	2	40	16712
BS 2.16	16 - 18 mm	32	40	2	40	16713
BS 2.18	18 - 20 mm	32	40	2	40	16714
BS 3.20	20 - 22 mm	36	48	2	45	16715
BS 3.22	22 - 23 mm	36	48	2	45	16716
BS 3.23	23 - 25 mm	36	48	2	45	16717
BS 3.25	25 - 27 mm	36	48	2	45	16718
BS 3.27	27 - 30 mm	36	48	2	45	16719
BS 3.30	30 - 34 mm	36	48	2	45	16721
BS 4.32	32 - 34 mm	56	69	2	65	16722
BS 4.34	34 - 36 mm	56	69	2	65	16723
BS 4.35	35 - 37 mm	56	69	2	65	16724
BS 4.38	38 - 40 mm	56	69	2	65	16725
BS 4.40	40 - 42 mm	56	69	2	65	16726
BS 4.42	42 - 44 mm	56	69	2	65	16727
BS 5.45	45 - 48 mm	65	85	2	75	16728
BS 5.48	48 - 51 mm	65	85	2	75	16729
BS 5.51	51 - 54 mm	65	85	2	75	16731

Other sizes and designs available on request!

Dimensions in mm

Type BS 1... - BS 5...

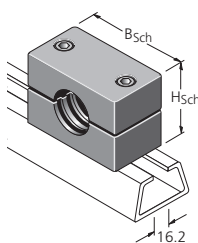

Assembly profile bars:

Material: Aluminium
Item-No.: 3926

Material: Steel
Item-No.: 3932

Material of the clamping jaws: PP

Assembly profile bars for strain relief devices



C-Profile 25 x 10 mm

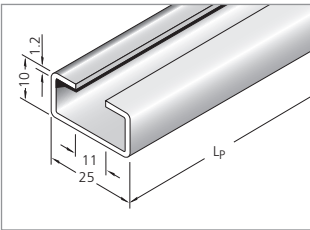

Fits all commercial clamps
(slit width 11 mm),
Types LineFix see page 302.

Material **Item-No.**
Steel 3931

Attach profile with M 6 – DIN 6912 sockethead cap screws.

C-Rail 25 x 12 mm

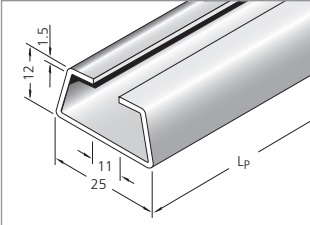

Fits all commercial clamps
(slit width 11 mm),
Types LineFix see page 302.

Material **Item-No.**
Steel 3934

Attach profile with M 6 – DIN 6912 sockethead cap screws.

C-Rail 34 x 15 mm

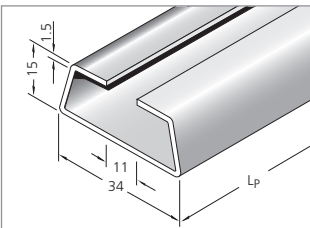

Fits all commercial clamps
(slit width 11 mm),
Types LineFix see page 302.

Material **Item-No.**
Steel 3935

Attach profile with M 6 – DIN 6912 sockethead cap screws.

C-Rail 34 x 15 mm

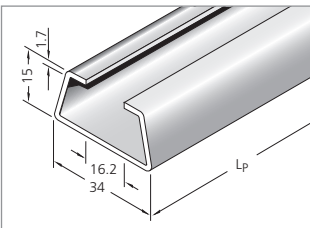

Fits all commercial clamps
(slit width 16 – 17 mm),
Types B see page 303.

Material **Item-No.**
Aluminium 3926
Steel 3932

Attach profile with M 10 – DIN 6912 sockethead cap screws.

Subject to change.

kabelschlepp.de

Font:
+49 2762 4003-0

OnlineEngineer.de
KABELSCHLEPP
Cable Carrier Configurator



Selection

BASIC
LINE

BASIC
LINEPLUS

VARIO
LINE

TUBE
SERIES

3D
LINE

STEEL
LINE

Installation
variants

Installation variants

Examples of different installation variants
of KABELSCHLEPP cable carriers

Examples of different installation variants

Horizontal arrangement "unsupported"

EBV 01

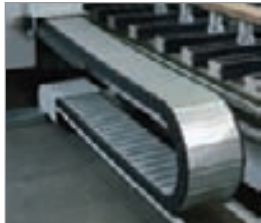
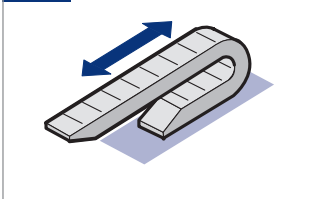

Horizontal arrangement "unsupported – overhanging"

EBV 02

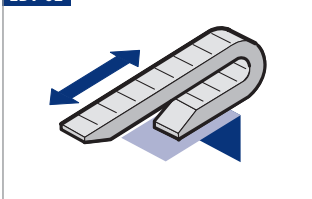

Horizontal arrangement "with permissible sag"

EBV 03

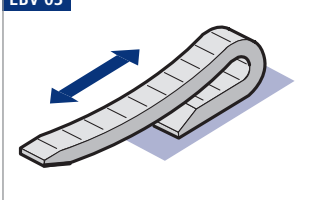

Horizontal arrangement "with support"

EBV 04

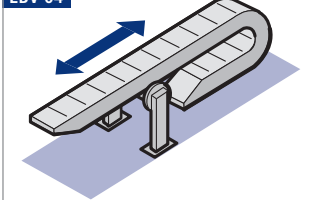

kabelschlepp.de

Fon: +49 2762 4003-0

Use our free project planning service.

Examples of different installation variants

Horizontal arrangement "gliding in a guide channel"

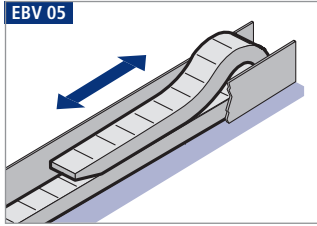

Horizontal arrangement "KabelSkate"

Roller system for travel paths up to 200 m and more

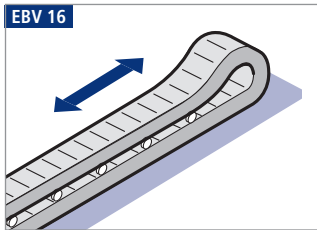

Horizontal arrangement "Rail Cable Carrier"

Roller system for travel paths up to 500 m and more

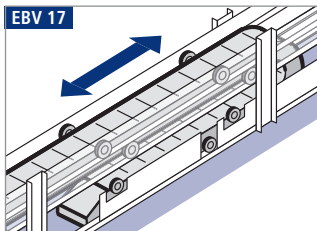

Horizontal arrangement "rotated through 90° – straight"

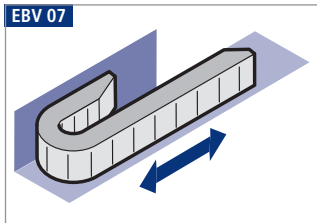

Subject to change.

BASIC LINE

BASIC LINE PLUS

VARIO LINE

TUBE SERIES

3D LINE

STEEL LINE

Installation variants

kabelschlepp.de

Fon: +49 2762 4003-0

OnlineEngineer.de
KABELSCHLEPP
Cable Carrier Configurator

Examples of different installation variants

Vertical arrangement "standing"

EBV 10

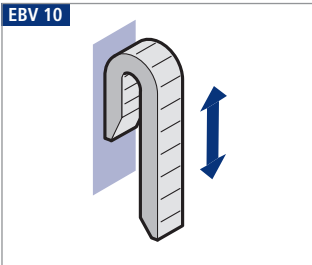

Vertical arrangement "hanging"

EBV 11

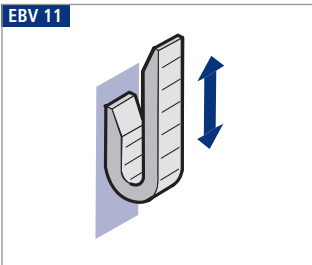

Horizontal/vertical arrangement "combined"

EBV 12

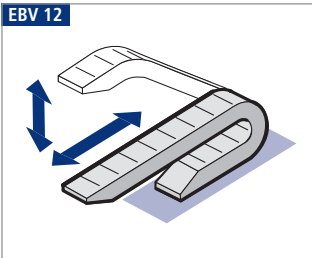

Examples of different installation variants

Horizontal arrangement "with continuous support structure"

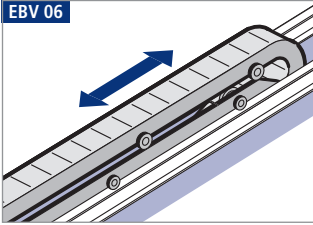

Arrangement "DYNAGLIDE"

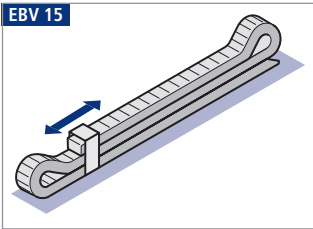

Vertical arrangement "hanging with load-bearing bolts"

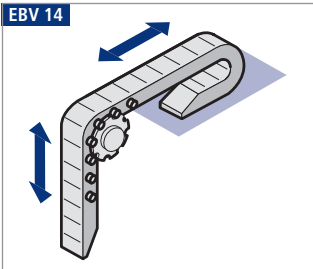

Rotating arrangements

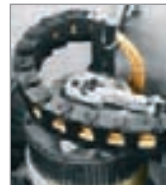
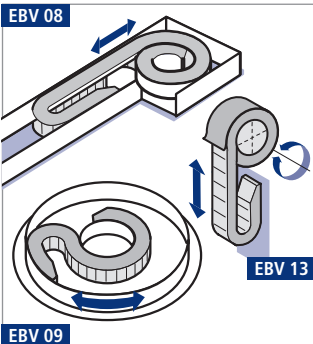

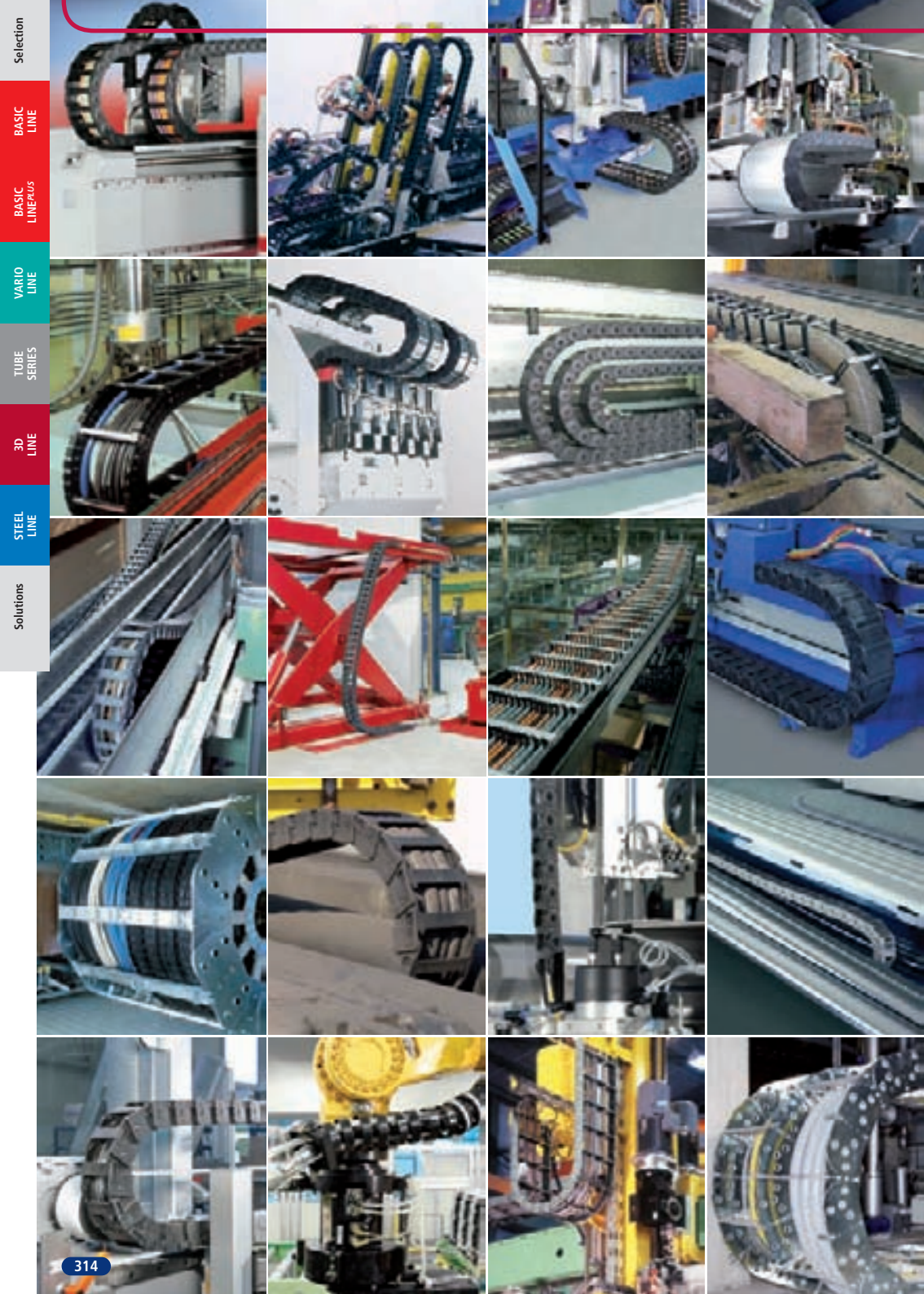

Selection

BASIC LINE

BASIC LINE PLUS

VARIO LINE

TUBE SERIES

3D LINE

STEEL LINE

Solutions

Application examples

KABELSCHLEPP cable carriers
made of plastic or steel in use

Application examples



UNIFLEX Series cable carrier on a CNC-machining center
Photographs:
Reichenbacher GmbH



UNIFLEX Series cable carriers on an automatic stove setting station
Photographs:
Lenhard Maschinenbau GmbH

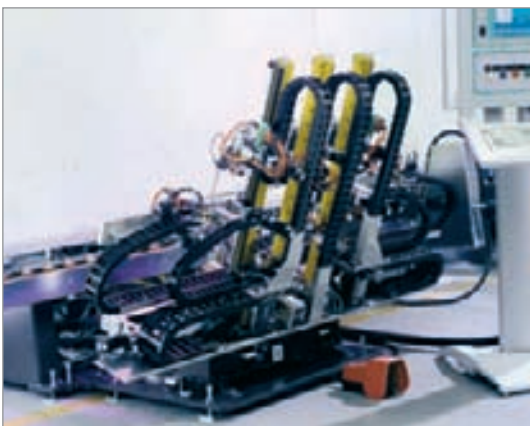

Application examples



Cable and hose carriers of the **UNIFLEX** and **MONO** series on a roll neck milling machine

Photographs:
Rottler Werkzeugmaschinen GmbH



Cable and hose carriers of the **MASTER LT** series on a tube end processing machine
Photographs: Rottler Werkzeugmaschinen GmbH

Subject to change.

Solutions

Selection

BASIC LINE

BASIC LINE PLUS

VARIO LINE

TUBE SERIES

3D LINE

STEEL LINE

Solutions

kabelschlepp.de

Font:
+49 2762 4003-0

OnlineEngineer.de
Web-Engineer
Cable Carrier Configurator

Application examples



MONO Series cable carrier systems, type 0450
Installation variants: horizontal "unsupported" – and vertical "standing"
Photograph: Reis Robotics



QUANTUM cable carrier system on a handling system
Photograph: SEW



QUANTUM cable carrier system on a handling system

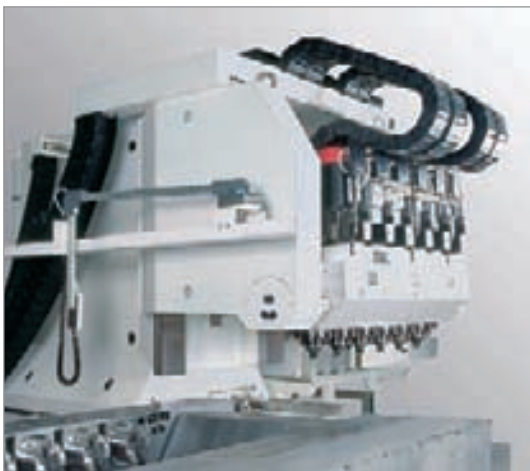

M Series cable carrier on a high-performance machining center
Photograph: Liechti Engineering AG

Application examples



UNIFLEX Series cable and hose carriers on an automatic wood processing machine
Photographs: Homag Holzbearbeitungssysteme AG



QUANTUM cable carrier system on a wood processing machine



MONO Series cable and hose carriers on a wood processing machine
Photographs: Krüsi Maschinenbau AG



Fon: +49 2762 4003-0

Use our free
project planning service.

Application examples



UNIFLEX Series cable and hose carriers on a scissored coil lift

Photographs: Grundei Hebetische Verladetechnik GmbH



M Series cable and hose carriers on a highrise rack

Photographs: BMW AG

Application examples



UNIFLEX cable carrier system in a zig-zag system on a lowerable multimedia cube in the Nuremberg Arena

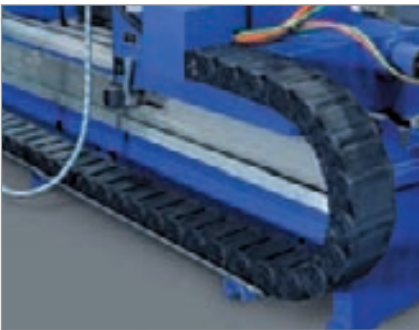

Type MT 0950 cable carrier on a roll grinding machine Installation variant: horizontal – "unsupported"

Photograph: Waldrich Siegen Werkzeugmaschinen GmbH



Type MK 0475 cable carrier for separating the cables in a steel cable carrier system, **Type 3200** on the ZEUS detector

Photograph: Deutsches Elektronen-Synchrotron, Hamburg

Application examples



MONO and UNIFLEX Series cable and hose carriers on a tow truck



UNIFLEX Series cable and hose carriers on a forklift
 Photograph: Ing. G+M Schurz GesmbH



MONO cable carriers on a pillar jib crane
 Photographs: VETTER Fördertechnik GmbH

Application examples



UNIFLEX Series cable carrier on a packaging machine
Photographs: Transnova-Ruf GmbH



ROBOTRAX, K Series and **M Series** cable carriers on a laser cutting machine
Photograph: Soudronic AG Automotive

Subject to change.

Solutions

Selection

BASIC LINE

BASIC LINEPLUS

VARIO LINE

TUBE SERIES

3D LINE

STEEL LINE

Solutions

kabelschlepp.de

Font: +49 2762 4003-0

OnlineEngineer.de
KABELSCHLEPP
Cable Carrier Configurator

Application examples



Type 0161 cable carrier system in an automobile sliding door



MONO and UNIFLEX Series cable carriers on packaging machines

Photographs: Transnova-Ruf GmbH

Application examples



ROBOTRAX cable carriers on a jointed-arm robot
Photographs: Daimler Chrysler AG

ROBOTRAX cable carrier system:
Angle of rotation about 180° without
channel system on a buckling arm
robot application
Photographs: Reis Robotics,
Arthur Bräuer GmbH & Co. KG

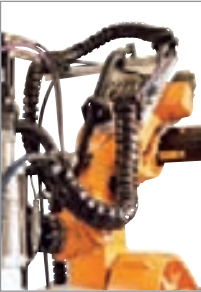

ROBOTRAX cable carriers on a jointed-arm robot
Photograph: SCA Schucker GmbH & Co.

ROBOTRAX cable carriers on an assembling system
Photographs: Gerstung Systemtechnik GmbH



ROBOTRAX cable carrier system on a combined portal and buckling arm robot application
Photographs: Güdel AG, Langenthal

Application examples



ROBOTRAX cable carrier system and steel cable carriers on a manipulator for handling crankcase core stackings
Photographs: Hottinger Maschinenbau GmbH

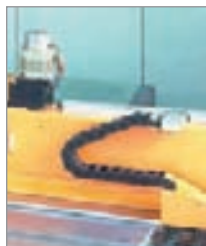

UNIFLEX Series cable carrier and **KABELSCHLEPP** telescopic cover on a highspeed machining center
Photograph: EiMa Maschinenbau GmbH

Application examples



Steel and plastic cable carriers and KABELSCHLEPP telescopic covers on a gantry milling machine
Photograph: Waldrich Siegen Werkzeugmaschinen GmbH



Steel cable carriers on a movable roof construction
Photographs: Lindenschmidt KG



Steel cable carriers with steel band cover on a shredding system
Photographs: Lindenschmidt KG



Steel cable carriers on a CNC drilling machine
Photographs: Rottler Rottler Werkzeugmaschinen GmbH

Application examples



Steel cable carriers on a scissored coil lift
Photographs: SÜDO GmbH

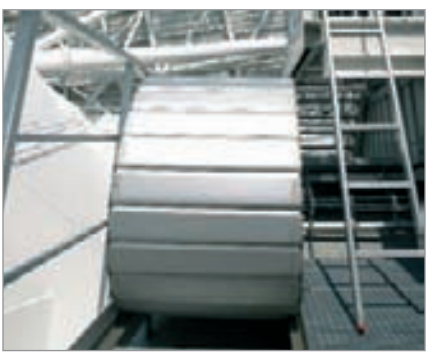

Steel cable carriers with aluminum cover system on a radio telescope
Photographs: Max-Planck-Institut für Radioastronomie

Application examples

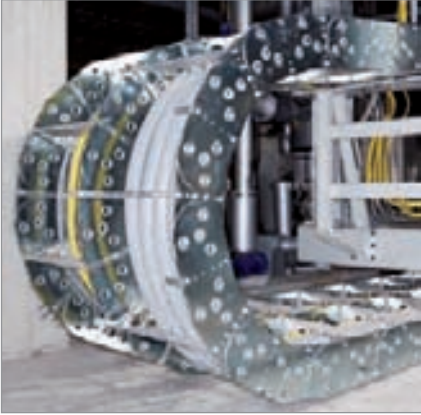

Steel cable carriers on a paper machine
Photographs: Voith Paper Technology Center GmbH



Steel cable carriers on a drilling system
Photograph: Prime Drilling GmbH



Steel cable carriers on a laser cutting machine
Photographs: Meyer Werft GmbH

Subject to change.

Solutions

Selection

BASIC LINE

BASIC LINE PLUS

VARIO LINE

TUBE SERIES

3D LINE

STEEL LINE

Solutions

kabelschlepp.de

Font: +49 2762 4003-0

OnlineEngineer.de
KABELSCHLEPP
Cable Carrier Configurator

BASIC-LINE

UNIFLEX

Ordering cable carrier



Ordering divider system

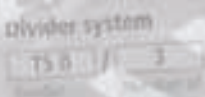

Please always refer to the description of the divider system (ES-Q, Ts 1-3) and number of rollers. Possible structure depends on the dimensions (see page 288).

Ordering plastic connectors



If no order designation for this connector is stated, the standard connection variant VA 32A (standard)



Connection point:

- H – Drive
- F – End point

Connection type:

- A – Threaded part, outside (standard)
- I – Threaded part, inside
- H – Threaded part, rotated through 90° to the outside
- E – Threaded part, rotated through 90° to the inside

The connector type can be changed later, simply by changing the connectors. For possible connection variants see the respective product description.

Ordering

Ordering key and sample orders
for KABELSCHLEPP cable carriers

BASIC-LINE

MONO

Ordering cable carrier – Types 0130 to 0202

Cable carrier

<input type="text" value="0202"/>	-	<input type="text" value="10"/>	-	<input type="text" value="28"/>	-	<input type="text" value="460"/>
Type		Inside width B _i in mm		Bend radius KR in mm		Chain length L _k in mm (without connection)

Ordering cable carrier – Types 0320 to 0625

Cable carrier

<input type="text" value="0625.65"/>	-	<input type="text" value="125"/>	-	<input type="text" value="1250"/>
Chain type		Bend radius KR in mm		Chain length L _k in mm (without connection)

Ordering divider system

Divider system

<input type="text" value="TS 0"/>	/	<input type="text" value="1"/>
Divider system		Number of dividers n _T

Please state the designation of the divider system (TS 0, TS 1 ...) and number of dividers. Possibly attach a sketch with the dimensions (see page 342).

Ordering connection

Connection

<input type="text" value="F"/>	/	<input type="text" value="A"/>	/	<input type="text" value="M"/>	/	<input type="text" value="A"/>
Fixed point		Connection type		Driver		Connection type

If no order designation for the connector is stated, we supply the connector variant **FA/MA (standard)**.

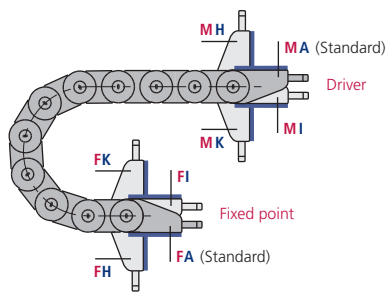

- Connection point**
- M** – Driver
 - F** – Fixed point

- Connection type**
- A** – Threaded joint outside (standard)
 - I** – Threaded joint, inside
 - H** – Threaded joint, rotated through 90° to the outside
 - K** – Threaded joint, rotated through 90° to the inside

BASIC-LINE

QuickTrax

Ordering cable carrier

Cable carrier	QT 0320	030	38	48	640
Type	Design	Inside width B_i in mm	Bend radius KR in mm	Chain length L_k in mm (without connection)	

Ordering divider system

Divider system	TS 0	1
Divider system	Number of dividers n_T	

Please state the designation of the divider system (TS 0, TS 1 ...) and number of dividers. Possibly attach a sketch with the dimensions (see page 342).

Ordering plastic connectors

Connection	F	A	M	A
Fixed point	Connection type	Driver	Connection type	

If no order designation for the connector is stated, we supply the connector variant **FA/MA (standard)**.

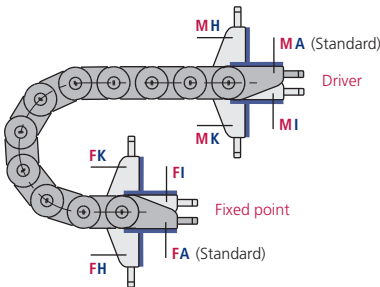

Connection point

- M – Driver
- F – Fixed point

Connection type

- A – Threaded joint outside (standard)
- I – Threaded joint, inside
- H – Threaded joint, rotated through 90° to the outside
- K – Threaded joint, rotated through 90° to the inside

The connector type can be changed later simply by changing the connectors.
 For possible connection variants see the respective product description.

BASIC-LINE

UNIFLEX *Advanced* / UNIFLEX

Ordering cable carrier

Cable carrier

1555	030	100	125	1332
Type	Design	Inside width B_i in mm	Bend radius KR in mm	Chain length L_k in mm (without connection)

Ordering divider system

Divider system

TS 0	3
Divider system	Number of dividers n_T

Please state the designation of the divider system (TS 0, TS 1 ...) and number of dividers. Possibly attach a sketch with the dimensions (see page 342).

Ordering plastic connectors

Connection

F	A	M	A
Fixed point	Connection type	Driver	Connection type

If no order designation for the connector is stated, we supply the connector variant **FA/MA (standard)**.

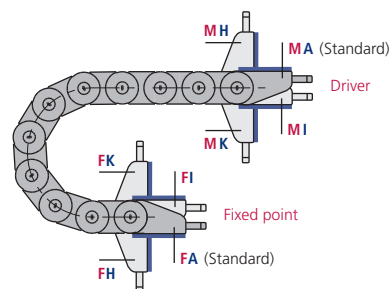

Connection point

- M** – Driver
- F** – Fixed point

Connection type

- A** – Threaded joint outside (standard)
- I** – Threaded joint, inside
- H** – Threaded joint, rotated through 90° to the outside
- K** – Threaded joint, rotated through 90° to the inside

The connector type can be changed later simply by changing the connectors.

For possible connection variants see the respective product description.

Ordering Universal Mounting Brackets (UMBs)

Connection

FU/MU
Connection Fixed point/Driver

For possible connection variants see the respective product description.

BASIC-LINE^{PLUS}

EasyTrax

Ordering cable carrier

Cable carrier	ET 0320	030	38	48	640
Type	Design	Inside width B_i in mm	Bend radius KR in mm	Chain length L_k in mm (without connection)	

Ordering divider system

Divider system	TS 0	1
Divider system	Number of dividers n_T	

Please state the designation of the divider system (TS 0, TS 1 ...) and number of dividers. Possibly attach a sketch with the dimensions (see page 342).

Ordering plastic connectors

Connection	F	A	M	A
Fixed point	Connection type	Driver	Connection type	

If no order designation for the connector is stated, we supply the connector variant FA/MA (standard).

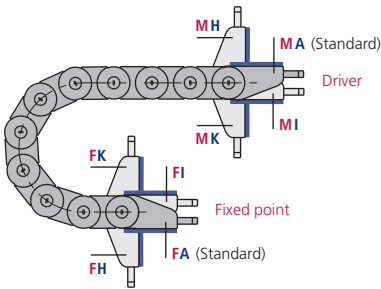

Connection point

- M – Driver
- F – Fixed point

Connection type

- A – Threaded joint outside (standard)
- I – Threaded joint, inside
- H – Threaded joint, rotated through 90° to the outside
- K – Threaded joint, rotated through 90° to the inside

The connector type can be changed later simply by changing the connectors.

For possible connection variants see the respective product description.

BASIC-LINE PLUS

PROTUM

Ordering cable carrier

Cable carrier	P 0240	010	30	42	380
Type	Design*	Inside width B _i in mm	Bend radius KR in mm	Chain length L _k in mm (without connection)	

* Design 010
(simple insertion of the cables)

Ordering connection

Connection	F	A	M	A
Fixed point	Connection type	Driver	Connection type	

When ordering **PROTUM OFFICE**, please specify connection. Specification of the bend radius is not necessary.

For possible connection variants see the respective product description.

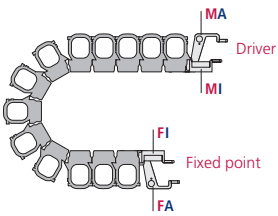

Connection point

- M** – Driver
- F** – Fixed point

Connection type

- A** – Threaded joint outside
- I** – Threaded joint, inside

kabelschlepp.de

PROfile®

Ordering modular cable carrier

Cable carrier	3	EM-3232	460
Number of modules	Module designation	Module length L _k in mm (without connection)	

Ordering connection

Connection	F	A	M	A
Fixed point	Connection type	Driver	Connection type	

No connecting elements are required for the modules EM-S15, EM-S45.20 and EM-S45 as well as EM-S67 and QM-45.23. These can be screwed on directly at the driver and the fixed point.

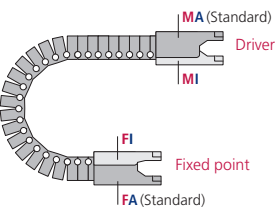

Connection point

- M** – Driver
- F** – Fixed point

Connection type

- A** – Threaded joint outside
- I** – Threaded joint, inside

Font: +49 2762 4003-0

Use our free project planning service.

Ordering radius clips

Radius clips	100	EC	75	32
Number of radius clips	Radius clips	Bend radius KR in mm	Module width in mm	

Joining rivet

Joining rivet	18	EN
Number of joining rivet	Connection rivet	

Special module

Special module	3	EM-S67	500
Number of Modules	Module designation (e.g. EM-S67)	Module length L _k in mm	

Part numbers for radius clips – see page 126.

Number of radius clips required: Single module: 25 pieces/m / Module combination: 2 x 25 pieces/m

VARIO-LINE

K Series / MASTER Series / M Series / XL Series / QUANTUM

Ordering cable carrier

Cable carrier

- - - -

Type	Inside width B _i in mm	Stay variant	Bend radius KR in mm	Chain length L _k in mm (without connection)
------	--------------------------------------	--------------	-------------------------	--

For Types 0320 and 0475 please specify the desired opening variant.

Ordering divider system

Divider system

/

Divider system	Number of dividers n _T
----------------	-----------------------------------

Please state the designation of the divider system (TS 0, TS 1 ...) and number of dividers. Possibly attach a sketch with the dimensions (see page 342).

Ordering Universal Mounting Brackets (UMBs)

Connection

Connection
Fixed point/
Driver

For possible connection variants see the respective product description.

Ordering

Selection

BASIC LINE

BASIC LINE PLUS

VARIO LINE

TUBE SERIES

3D LINE

STEEL LINE

Ordering

kabelschlepp.de

Font:
+49 2762 4003-0

OnlineEngineer.de

 The Cable Carrier Configurator

VARIO-LINE

TKR 0200

Ordering cable carrier

Cable carrier

TKR 0200	100	95	800
Type	Inside width B _i in mm	Bend radius KR in mm	Chain length L _k in mm (without connection)

Ordering divider system

Divider system

TS 0	3
Divider system	Number of dividers n _T

Please state the designation of the divider system (TS 0, TS 1 ...) and number of dividers. Possibly attach a sketch with the dimensions (see page 342).

Ordering plastic connectors

Connection

F	A	M	A
Fixed point	Connection type	Driver	Connection type

If no order designation for the connector is stated, we supply the connector variant **FA/MA (standard)**.

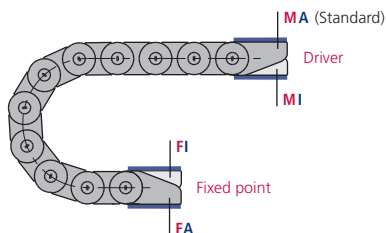

Connection point

- M – Driver
- F – Fixed point

Connection type

- A – Threaded joint outside (standard)
- I – Threaded joint, inside

The connector type can be changed later simply by changing the connectors.

For possible connection variants see the respective product description.

TUBE-SERIES

Ordering cable carriers, divider systems and connectors

According to the ordering keys of the particular LINE; see pages 334 – 341.

3D-LINE

ROBOTRAX

Ordering cable carrier

Cable carrier			
R 075	010	145	1000
Type	Design*	Bend radius KR in mm	Chain length L _k in mm (without connection)

* Design 010 (simple insertion of the cables)

Ordering accessories: please state separately.

STEEL-LINE

LS/LSX Series

Ordering cable carrier

Cable carrier					
LS 1050	180	RS 2	125	Sb	2500
Type	Stay width B _{St} in mm	Stay variant	Bend radius KR in mm	Chain band material	Chain length L _k in mm (without connection)

Chain band materials: Sb = Steel specially coated / ER 1 = Stainless steel / ER 1S = Stainless steel, sea water resistant Please contact us for further information about the chain band materials.

Ordering divider system

Divider system	
TS 0	4
Divider system	Number of dividers n _T

Please state the designation of the divider system (TS 0, TS 1 ...) and number of dividers. Possibly attach a sketch with the dimensions (see page 342).

Ordering connectors

Connection				
F	A	I / M	A	I
Fixed point	Connection type	Connecting surface	Driver	Connection type

If no order designation for the connector is stated, we supply the connector variant **FA/MA (standard)**.

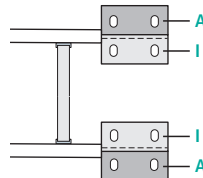
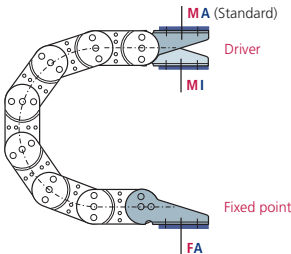

Connection point

- M** – Driver
- F** – Fixed point

Connection type

- A** – Threaded joint outside (standard)
- I** – Threaded joint, inside

Connecting surface

- I** – Connecting surface inside (< B_k)
- A** – Connecting surface outside (< B_k)

For possible connection variants see the respective product description.

STEEL-LINE

S/SX Series

Ordering cable carrier

Cable carrier

S 0950	300	RS 1	200	St	3150
Type	Stay width B _{St} in mm	Stay variant	Bend radius KR in mm	Chain band material	Chain length L _k in mm (without connection)

Chain band materials: Sb = Steel specially coated / ER 1 = Stainless steel / ER 1S = Stainless steel, sea water resistant

Please contact us for further information about the chain band materials.

Ordering divider system

Divider system

TS 0	4
Divider system	Number of dividers n _T

Please state the designation of the divider system (TS 0, TS 1 ...) and number of dividers. Possibly attach a sketch with the dimensions (see page 342).

Ordering connectors

Connection

F	A	I	M	A	I
Fixed point	Connection type	Connecting surface	Driver	Connection type	Connecting surface

If no order designation for the connector is stated, we supply the connector variant **FA/MA (standard)**.

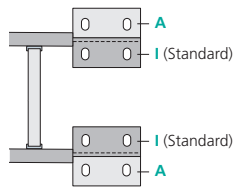
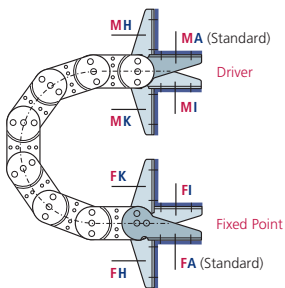

Connection point

- M – Driver
- F – Fixed point

Connection type

- A – Threaded joint outside (standard)
- I – Threaded joint, inside
- H – Threaded joint, rotated through 90° to the outside
- K – Threaded joint, rotated through 90° to the inside

Connecting surface

- I – Connecting surface inside (< B_k)
- A – Connecting surface outside (< B_k)

The connecting surfaces on the driver and fixed point can be mounted on the outside or inside according to preference.

The connector type can be changed later simply by changing the connectors.

For possible connection variants see the respective product description.

kabelschlepp.de

Fon: +49 2762 4003-0

Use our free project planning service.

STEEL-LINE

CONDUFLEX / MOBIFLEX

Ordering cable carrier

Cable carrier

CF 120 - **140** - **1200**

CONDUFLEX/
MOBIFLEX
Type

Bend radius
KR in mm

Conduit length
L_{ES} in mm (with-
out connection)

Ordering connection

Connection

F / **QF** / **M** / **HF**

Fixed point

Connection
type

Driver

Connection
type

Connection variants for diagonal flange connectors SF

Connection
surface
outside/
outside

1

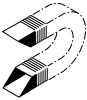

Connection
surface
inside/
outside

2

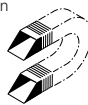

Connection
surface
inside/
inside

3

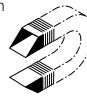

Connection variants for standard connectors ST

Connection
surface
outside/
outside

1

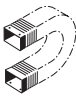

Connection
surface
inside/
outside

2

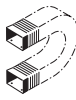

Connection
surface
inside/
inside

3

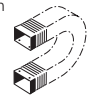

Please state the position of the connecting surfaces for connection variants SF and ST when ordering.

Guide channels
► from page 295

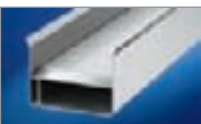

Strain relief devices
► from page 302



Cables for cable carrier systems
► from page 344



Ordering divider system – sample drawings

Divider system TS 0



Divider system TS 1

with continuous height subdivision made of aluminium

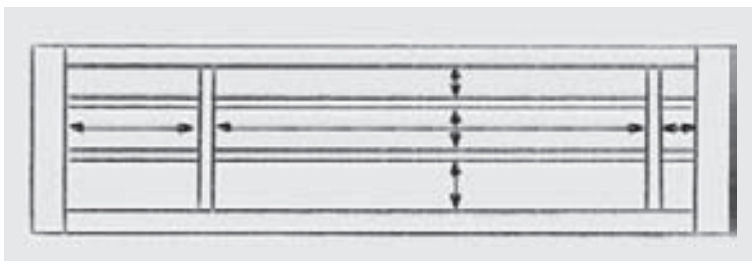

Divider systems TS 2 / TS 3

with partitioned height subdivision made of plastic or aluminium

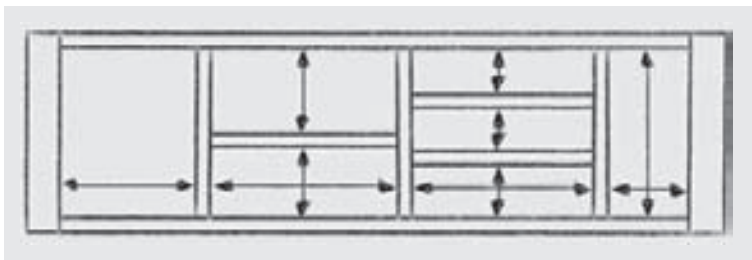

When ordering the divider system, please attach a sketch with the dimensions.

Notes

Subject to change.

Ordering

Selection

BASIC
LINE

BASIC
LINE PLUS

VARIO
LINE

TUBE
SERIES

3D
LINE

STEEL
LINE

kabelschlepp.de

Ordering

Fon:
+49 2762 4003-0

OnlineEngineer.de
KABELSCHLEPP
Cable Carriers Configurator





2

LIFE-LINE Safety Cables



CONTINUOUS BENDING HI-FLEX ELECTRICAL CABLES

TOTALTRAX TURN-KEY SYSTEMS

PRE-ASSEMBLED CABLES

STRAIN RELIEF DEVICES

... FOR CABLE CARRIERS

Durable, reliable, cost-effective

LIFE-LINE – cables for cable carriers

Perfect solutions – your advantage

KABELSCHLEPP – the inventor of the cable carrier. Our product portfolio covers more than 100,000 variants made of steel and plastic, allowing us to deliver a suitable and reliable cable carrier for every application – from standard off-the-shelf products to custom-designed complete solutions. Wherever you are in the world, we are here to help. We use our over 50 years of experience to continuously develop and refine the “insides” – i.e. the LIFE-LINE cables – and to constantly adapt them to the market requirements.

Our cable ranges meet the highest quality standards in order to ensure availability of your systems and installations.

With the LIFE-LINE range, we offer a selection of cables which are cost-effective, flexible and extremely durable.

A key factor for our cables is their tested and proven operational reliability, which meets all applicable standards and directives.

Competent, objective-driven systems consultation and global on-site service are both part of what we consider an on-going commitment to the technical and commercial optimisation of your applications.

KABELSCHLEPP cable warehouse

Several hundred cable types, stored constantly in our cable warehouse, secure a fast availability all around the world. We deliver according to your requirements, no minimum quantities, each length without cutting costs.



■ KABELSCHLEPP cable warehouse.

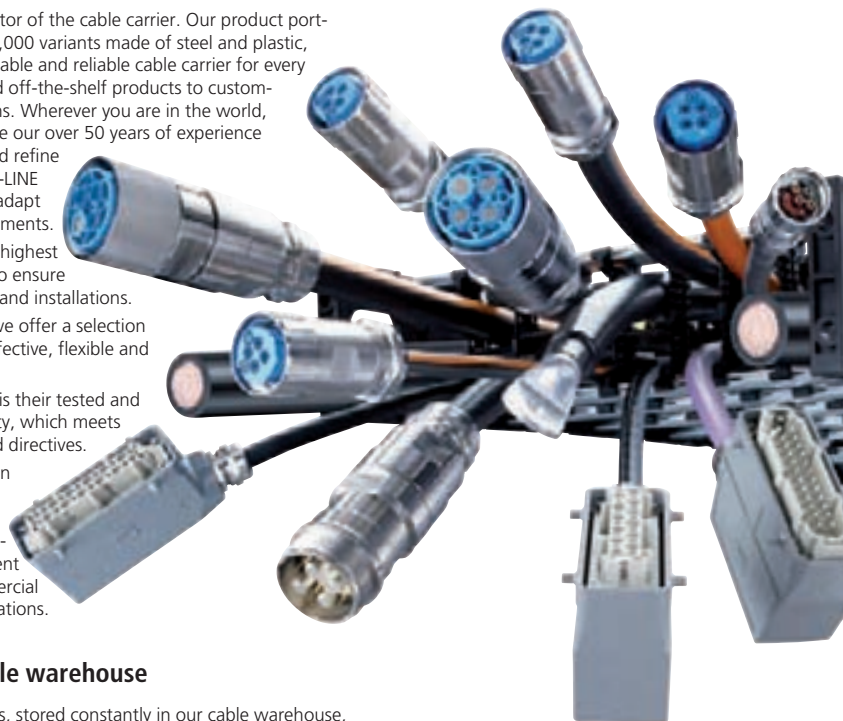

The successful KABELSCHLEPP LIFE-LINE cable program was extended and optimized as an innovative standard product line, especially for the installation of cables in dynamic cable and hose carrier systems. Our clearly structured type selection offers a unique combination of performance features.

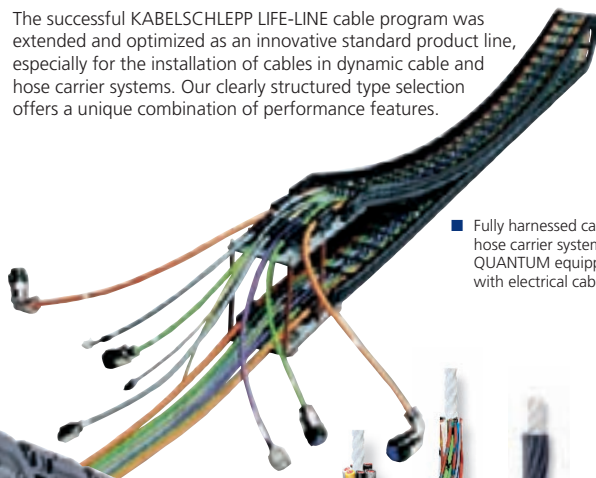

- Fully harnessed cable and hose carrier system QUANTUM equipped with electrical cables.



ICC
KABELSCHLEPP
Integrated Colour Code

- Co-extruded **ICC** color identification based on DESINA color code. Power, control and BUS cables etc. have different color codes to be easily visually differentiated. Thus, shorter assembly or service times result in cost reduction.
- The **ICC** color code system also serves as **helpful tool** when installing the cables into the carrier.
- **UV-resistant** black outer jacket for outdoor and indoor applications.

Overview of cable types 348

Overview after ranges of application 354

TOTALTRAX Turn-Key Systems 356

Control cables 358

Power cables 370

Data cables 384

BUS-/LWL-/Coaxial cables 388

System cables 404

Pre-assembled cables 412

Technical data, further information 417

Overview LIFE-LINE types

Cable type	Outer jacket	Shield	Dynamic bend radius	Temperature moved	Approvals
------------	--------------	--------	---------------------	-------------------	-----------

Control cables

Control 200		PVC	–	9	-5 to +80 °C	 
Control 200 C		PVC	✓	11	-5 to +80 °C	 
Control 400		PVC	–	7.5	-5 to +80 °C	 
Control 400 C		PVC	✓	7.5	-5 to +80 °C	 
Control 700		PUR	–	7.5	-30 to +90 °C	 
Control 700 C		PUR	✓	7.5	-30 to +90 °C	 

Power cables

Power 400		PVC	–	7.5	-5 to +80 °C	 
Power 400 C		PVC	✓	7.5	-5 to +80 °C	 
Power 700 / 700 PE/3		PUR	–	7.5	-30 to +90 °C	 
Power ONE 700		PUR	–	7.5	-30 to +90 °C	 
Power ONE 700 PE		PUR	–	7.5	-30 to +90 °C	 
Power 700 C / 700 C PE/3		PUR	✓	7.5	-30 to +90 °C	 
Power ONE 700 C		PUR	✓	7.5	-30 to +90 °C	 

Data cables

Data 700 C		PUR	✓	7.5	-30 to +90 °C	 
Data / Data/Power 700 CD		PUR	✓	7.5	-30 to +90 °C	 

Cable overview after article numbers ► Page 431

Standards	Color DESINA color/ ICC	Halogen-free	Flame-retardant	Oil-resistant	V _{max} unsupported (m/s)	V _{max} gliding (m/s)	a _{max} (m/s ²)	Diameter mm2/ Type/Other	Core number	Page
-----------	-------------------------------	--------------	-----------------	---------------	---------------------------------------	-----------------------------------	---	-----------------------------	-------------	------

358

	grey	-	✓	✓	3.5	2	10	0.5 ² to 2.5 ²	2-25	358
	grey	-	✓	✓	3.5	2	10	0.75 ² to 1.5 ²	4-25	360
	grey	-	✓	✓	10	5	20	0.34 ² to 2.5 ²	3-48	362
	grey	-	✓	✓	10	5	20	0.25 ² to 1.5 ²	3-36	364
	grey	✓	✓	✓	20	5	50	0.25 ² to 2.5 ²	1-36	366
	grey	✓	✓	✓	20	5	50	0.34 ² to 1 ²	3-25	368

370

	black	-	✓	✓	5	3	20	1.5 ² to 35 ²	3-25	370
	orange	-	✓	✓	5	3	20	1.5 ² to 25 ²	4-7	372
	black	✓	✓	✓	20	5	50	1.5 ² to 95 ²	3-36	374
	black	✓	✓	✓	20	5	50	1.5 ² to 500 ²	1	376
	black	✓	✓	✓	20	5	50	4 ² to 50 ²	1	378
	orange	✓	✓	✓	20	5	50	1.5 ² to 95 ²	2-36	380
	black	✓	✓	✓	20	5	50	2.5 ² to 300 ²	1	382

384

	purple	✓	✓	✓	20	5	50	0.25 ² to 0.75 ²	4-28	384
	purple	✓	✓	✓	20	5	50	0.25 ² to 1.5 ²	6-12	386

Cable overview after article numbers ► Page 431



Overview LIFE-LINE types

Cable type	Outer jacket	Shield	Dynamic bend radius	Temperature moved	Approvals
------------	--------------	--------	---------------------	-------------------	-----------

BUS-/fiber optic-/coaxial cables

Profibus 700 C		PUR	✓	15	-20 to +60 °C	
CAN-BUS 700 C		PUR	✓	7.5	-30 to +70 °C	
USB 2.0 700 C		PUR	✓	10	-10 to +70 °C	
Interbus 700 C		PUR	✓	12	-30 to +70 °C	
CAT5 700 C		PUR	✓	7.5	-20 to +60 °C	
DeviceNet 700 C		PUR	✓	7.5	-30 to +70 °C	
Koax 700 C / 700 CD		PUR	✓	14	-5 to +50 °C	
LWL 700		PUR	–	7.5	-30 to +90 °C	–

System cables

System S 800 C		PUR	✓	7.5	-30 to +90 °C	
System M 800 C		PUR	✓	7.5	-30 to +90 °C	
System S 900 C		PUR	✓	7.5	-30 to +90 °C	
System M 900 C		PUR	✓	7.5	-30 to +90 °C	



Cable overview after article numbers ► Page 431

Standards	Color DESINA color/ ICC	Halogen-free	Flame-retardant	Oil-resistant	V _{max} unsupported (m/s)	V _{max} gliding (m/s)	a _{max} (m/s ²)	Diameter mm ² / Type/Other	Core number	Page
-----------	-------------------------------	--------------	-----------------	---------------	---------------------------------------	-----------------------------------	---	--	-------------	------

388

	purple	✓	✓	✓	3.5	2	10	0.5 ²	2	388
	purple	✓	✓	✓	3.5	2	10	0.5 ²	2-4	390
	purple	✓	✓	✓	3.5	2	10	(1 x 2 x 28 AWG + 2 x 20 AWG)	4	392
	purple	✓	✓	✓	3.5	2	10	0.25 ² to 1 ²	9	394
	green	✓	✓	✓	3.5	2	10	0.15 ²	8	396
	purple	✓	✓	✓	3.5	2	10	0.75 ² to 1 ²	4	398
	black	-	-	✓	3.5	2	10	HF50/HF75	1-3	400
	black	✓	✓	✓	4	4	10	50μ/62.5μ	6-12	402

404

	green	✓	✓	✓	6	3	8	0.14 ² to 0.5 ²	4-16	404
	orange	✓	✓	✓	6	3	8	1.5 ² to 50 ²	4-6	406
	orange	✓	✓	✓	6	3	8	0.14 ² to 1 ²	10-36	408
	orange	✓	✓	✓	6	3	8	0.75 ² to 35 ²	8	410



Cable overview after article numbers ► Page 431

Overview LIFE-LINE pre-assembled



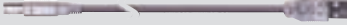
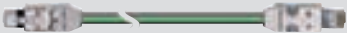

USB / CAT5 413

USB 700 C pre-assembled		413
CAT5 700 C pre-assembled		413

Signal cables Cables with connections compatible with the SIEMENS standard 414

Signal basic cables		414
Signal extension cables		414

Power cables Cables with connections compatible with the SIEMENS standard 415

Power basic cables without brake wires		415
Power extension cables without brake wires		415
Power basic cables with brake wires		415
Power extension cables with brake wires		416

Technical Data, further information Page

Application parameters	417	Abbreviation	421
Electrical load capacity	418	Chemical resistance	422
Conversion factors		Test results	423
for ambient temperatures	418	Installing cables into the cable carrier	424
Color codes, copper surcharge, AWG table	419	LIFE-LINE Scout – inquiry form	426
Copper wire dimensions acc. to AWG	419	Application examples	427
Copper price calculation	420	Definitions	428
Definitions	421	Overview after article numbers	431

Cable overview after article numbers ► Page 431

KABELSCHLEPP and EPLAN

EPLAN has developed over more than 20 years into a leading E-CAD system and has become more-or-less established as a standard in some branches.

LIFE-LINE cable database for EPLAN

As a provider of highly-flexible electrical cables for cable and hose carriers, we offer you the KABELSCHLEPP LIFE-LINE cable data bases as a superior tool for optimising your daily work with EPLAN.

The databases are optimized for use in EPLAN5 and for transmission according to EPLAN P8 electric.

- easy cable selection by construction
- automatic addition of core number, cross-section and core colour
- complete data for parts lists and other evaluations

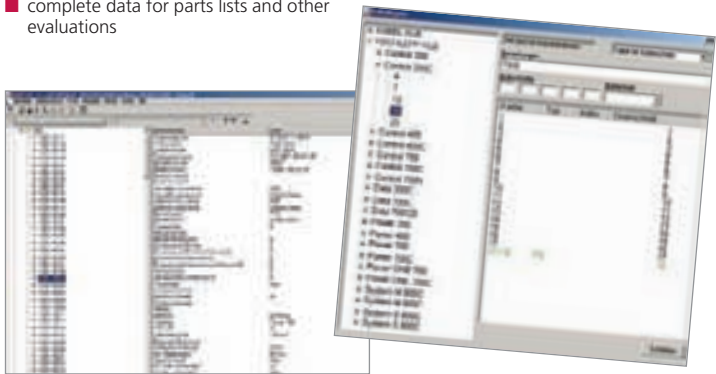

Cable overview after article numbers ► Page 431

PVC control cables

Control 200	Page 358
Control 200 C	Page 360



- Cost-effective standard control cables **for a wide range of applications**
- Self-supporting and gliding applications with normal load for average bend radii as well as speeds
- Black outer jacket for high UV-resistance, also suitable for outdoor applications; co-extruded **ICC** color code Identification based on DESINA color code simplifies the correct cable installation into the carrier

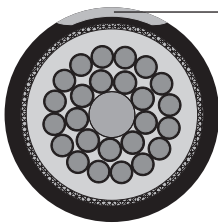

ICC
KABELSCHLEPP
Integrated Colour Code

■ Example of layered stranding shielded design

PVC control cables

Control 400	Page 362
Control 400 C	Page 364



- Control cables **for more challenging applications**
- Self-supporting and gliding applications with small bend radii and high speeds
- Black outer jacket for high UV-resistance, also suitable for outdoor applications; co-extruded **ICC** color code Identification based on DESINA color code simplifies the correct cable installation into the carrier

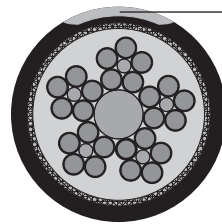

ICC
KABELSCHLEPP
Integrated Colour Code

■ Example of bundled stranding shielded design with 25 cores

PUR control cables

Control 700	Page 366
Control 700 C	Page 368



- High-quality PUR control cables **for even the most challenging applications**
- Self-supporting and gliding applications with smallest bend radii and very high speeds; especially suitable for long travel lengths
- For indoor and outdoor applications
- Optimized bundle-stranding > 8 strands for highest availability
- Shielded design with continuous bending hi-flex braided shield

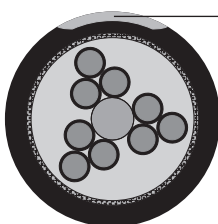

ICC
KABELSCHLEPP
Integrated Colour Code

■ Example of bundled stranding shielded design

PUR BUS/Koax/LWL cables

Profibus, CAN-BUS, USB, Interbus, CAT5, DeviceNet, Koax, LWL 700	Page 388
---	----------



- Super-flexible, continuous bending hi-flex and robust PUR-BUS-/Koax-/LWL cables
- For universal and extremely challenging applications in cable carriers
- For self-supporting and long gliding applications with small bend radii

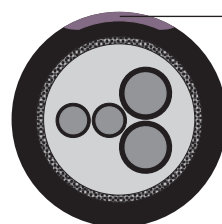

ICC
KABELSCHLEPP
Integrated Colour Code

■ Example of USB design

PVC power cables

Power 400 Page 370
Power 400 C Page 372



- High-quality, robust PVC motor cables for challenging applications
- Self-supporting and gliding applications for small bend radii and high speeds
- Particularly suitable for long travel lengths
- Suitable for indoor and outdoor applications
- High wear-resistant and robust outer jacket

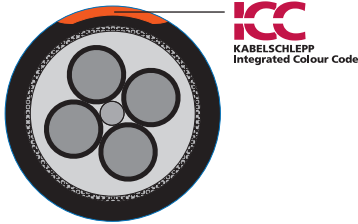

■ Example of layered stranding shielded design

PUR power cables

Power 700/ONE 700/ONE 700 PE Page 374
Power 700 C/ONE 700 C Page 380



- High-quality, robust PUR motor cables for even the most challenging applications
- Self-supporting and gliding applications for very small bend radii and very high speeds
- Particularly suitable for long travel lengths
- For indoor and outdoor applications
- High wear-resistant and nick-resistant outer jacket
- Individual strands with double-jacket
- Shielded design with continuous bending hi-flex braided shield

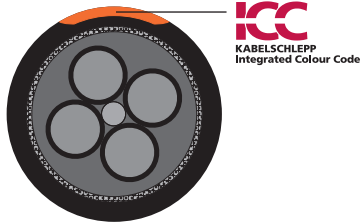

■ Example of layered stranding shielded design

PUR data cables

Data 700 C Page 384
Data 700 CD Page 386



- Super-flexible, continuous bending hi-flex and robust PUR data cables with inner jacket
- Pair-stranding cabling and complete shielding – suitable for critical EMC environments
- For universal and extremely challenging applications in cable carriers
- For self-supporting and very long gliding applications with small bend radii
- Particularly suitable for high speeds and accelerations
- Double shielded CD version

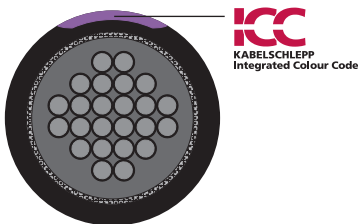

■ Example of pair-stranding shielded design

PUR system cables

System S 800 C/M 800 C Page 404
System S 900 C/M 900 C Page 408



- High-quality PUR combi-cables for challenging system applications
- Self-supporting and gliding applications for small bend radii and high speeds
- For indoor and outdoor applications
- Reliable transmission according to SIEMENS-, INDRAMAT, Heidenhain or Baumüller specifications

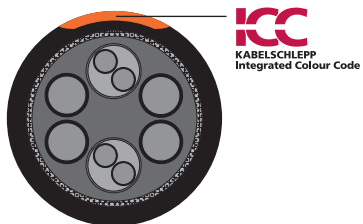

■ Example of motor cable with control strands

TOTALTRAX turn-key systems

Fully harnessed cable carrier systems

You know what product you need – we supply it to you completely harnessed

One supplier and contact person for the complete system

We develop, design and supply all components required for your individual cable & hose carrier system.



■ Ready-to-connect assembled plastic cable carrier system, packed ready for installation

Everything from a single source

- Consulting
- Planning
- Design
- Cable carriers
- Electrical cables
- Complete guarantee
- Hydraulic hoses
- Pneumatic hoses
- Plug-and-socket connectors
- Assembly plates
- Complete assembly of all components

- + One contact person
- + One order
- + One delivery
- + Guaranteed quality

= **TOTALTRAX Complete System**

TOTALTRAX – from design to the complete system



NOTE:

Harnessed cables according to SIEMENS- or Bosch-Rexroth/INDRAMAT specifications

We manufacture KABELSCHLEPP LIFE-LINE cables according to SIEMENS- or Bosch-Rexroth/INDRAMAT specifications, suitable for SIEMENS- or Bosch-Rexroth/INDRAMAT drive controls which consist of signal and power cables and/or extension cables.

- any cable length available
- delivery minimum: 1 unit

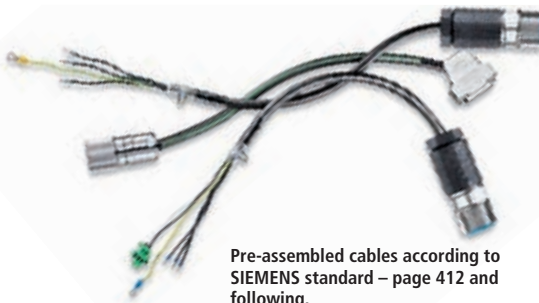

Pre-assembled cables according to SIEMENS standard – page 412 and following.

Cut costs with TOTALTRAX complete cable carrier systems

We help you . . .

- Support in the design phase
- Only one contact person for the complete system including all the individual components
- Complete delivery from a single source
- Only one supplier – one purchase order and one item number
- All components match each other perfectly
- Guarantee certificate upon requests

. . . to cut your costs!

- Goods receiving inspections for all individual components are no longer required
- Expensive technical personnel and special tools are no longer required
- Shorter assembly times
- No hidden costs, e.g. cables being cut to excessive lengths etc.
- Less captive capital with almost no inventory
- On-time delivery directly to your production site

No storage costs for individual components like cables and connectors

Our warehouses offer cables, plug-and-socket connectors as well as many other individual components.



■ Complete system with reusable shipping fixture

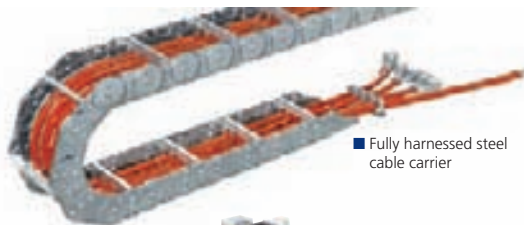

■ Fully harnessed steel cable carrier

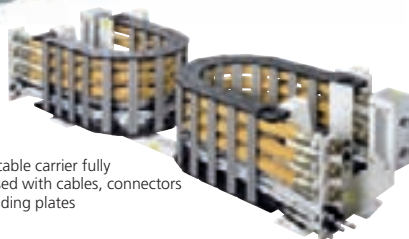

■ Plastic cable carrier fully harnessed with cables, connectors and holding plates

Complete service – even for applications with extreme assembly conditions

Our service team can design and assemble your cable carrier system even for applications with extreme assembly conditions. Our service center experts provide you with the support you need.

- Complete assembly with guide channels
- Uncoiling of harnessed cable carrier systems with long travel lengths
- Assembly at great heights (e. g. crane systems)



■ Fully harnessed cable carrier system in shipping crate



■ Assembly of the fully harnessed cable carrier system



Core insulation
KS-PVC
layered



Outer jacket
KS-PVC
valley-sealed extruded
hi-flex design
UV-resistant
very abrasion-resistant



Jacket color
co-extruded
ICC color identification
based on
DESINA color code

LIFE-LINE Control 200

Unshielded continuous bending hi-flex PVC control cables



Up to
2 million
motion cycles!



Up to
25 m
travel length!

LIFE-LINE
cables for
cable carriers

ICC
KABELSCHLEPP
Integrated Colour Code

RoHS
conform

Developed for

- systems engineering and mechanical engineering
- crane and conveyor equipment
- monitoring, measuring and control cables
- light to medium loads

Properties

- oil-resistant
- UV-resistant
- CFC-free
- flame-retardant
- silicone-free
- RoHS-conform

Design

Conductor:	finely stranded bare copper wires in an optimized hi-flex design
Center element:	type-dependent
Core insulation:	KS-PVC
Core identification:	black with white numbers, protective conductor green/yellow
Core stranding:	conductor cores layered
Outer jacket:	KS-PVC
Jacket color:	black with ICC color identification based on the DESINA color code

Technical Data

Temperature range:	- 5 to + 80 °C
Minimum bend radius while moved:	$KR_{min} \geq 9 \times \varnothing$
v_{max} unsupported:	3.5 m/s
v_{max} gliding:	2 m/s
a_{max}:	10 m/s ²
Insulation resistance:	≥ 10 MΩ x km
Rated voltage:	according to VDE 300/500V according to UL 300V
Approvals:	UL, CSA (type-dependent), based on VDE



Type selection

LIFE-LINE Control 200 – UNSHIELDED

core number x nominal-cross-section in mm ²	conductor cross section AWG (approximate values)	article number	max. OD in mm	weight kg/m	Cu index kg/m
2 x 0.5 ²	19 / 2c	48361	5.4	0.038	0.010
3 x 0.5 ²	20 / 3c	48362	5.7	0.041	0.015
5 x 0.5 ²	20 / 5c	48364	6.7	0.059	0.024
7 x 0.5 ²	20 / 7c	48366	7.9	0.083	0.035
18 x 0.5 ²	20 / 18c	48374	11.5	0.190	0.087
25 x 0.5 ²	20 / 25c	48378	14.0	0.260	0.125
4 x 0.75 ²	18 / 4c	48000	6.7	0.060	0.029
7 x 0.75 ²	18 / 7c	48001	8.8	0.110	0.053
12 x 0.75 ²	18 / 12c	48002	10.3	0.160	0.087
18 x 0.75 ²	18 / 18c	48003	12.2	0.240	0.130
25 x 0.75 ²	18 / 25c	48004	15.4	0.330	0.180
4 x 1 ²	17 / 4c	48005	7.2	0.080	0.040
7 x 1 ²	17 / 7c	48006	9.5	0.135	0.068
12 x 1 ²	17 / 12c	48007	11.4	0.205	0.116
18 x 1 ²	17 / 18c	48008	13.4	0.305	0.174
25 x 1 ²	17 / 25c	48009	16.0	0.415	0.246
4 x 1.5 ²	16 / 4c	48010	8.0	0.094	0.058
5 x 1.5 ²	16 / 5c	48011	8.9	0.136	0.072
7 x 1.5 ²	16 / 7c	48012	10.3	0.175	0.101
12 x 1.5 ²	16 / 12c	48013	13.0	0.270	0.173
18 x 1.5 ²	16 / 18c	48014	14.5	0.390	0.260
25 x 1.5 ²	16 / 25c	48015	18.6	0.565	0.360
4 x 2.5 ²	14 / 4c	48016	9.5	0.174	0.100





Core insulation
KS-PVC
layered



Inner jacket
KS-PVC
valley-sealed,
pressure extruded,
hi-flex design



Overall shield
high flexural strength,
tin-plated copper braiding
for smallest bend radii
Coverage: approx. 80 %



Outer jacket
KS-PVC
pressure extruded
hi-flex design
UV-resistant
very abrasion-resistant



Jacket color
co-extruded
ICC color identification
based on
DESINA color code



Up to
2 million
motion cycles!



Up to
25 m
travel length!

LIFE-LINE
cables for
cable carriers

ICC
KABELSCHLEPP
Integrated Colour Code

RoHS
conform

Developed for

- systems engineering and mechanical engineering
- crane and conveyor equipment
- monitoring, measuring and control cables
- light to medium loads

Properties

- oil-resistant
- UV-resistant
- RoHS-conform
- CFC-free
- silicone-free
- flame-retardant

Design

Conductor:	finely stranded bare copper wires in an optimized hi-flex design
Center element:	type-dependent
Core insulation:	KS-PVC
Core identification:	black with white numbers, protective conductor green/yellow
Core stranding:	conductor cores layered
Shielding:	coverage 80 %
Outer jacket:	KS-PVC
Jacket color:	black with ICC color identification based on the DESINA color code
Inner jacket:	KS-PVC

Technical Data

Temperature range:	- 5 to + 80 °C
Minimum bend radius while moved*:	$KR_{min} \geq 11 \times \varnothing$
v_{max} unsupported:	3.5 m/s
v_{max} gliding:	2 m/s
a_{max}:	10 m/s ²
Insulation resistance:	$\geq 10 \text{ M}\Omega \times \text{km}$
Rated voltage:	according to VDE 300/500V according to UL 300V
Approvals:	UL, CSA (on request), based on VDE

* smaller bend radii are suitable in a wide range of applications – please contact us

Type selection

LIFE-LINE Control 200 C – SHIELDED

core number x nominal-cross-section in mm ²	conductor cross section AWG (approximate values)	article number	max OD in mm	weight kg/m	Cu index kg/m
(4 x 0.75 ²)	(18 / 4c)	48020	8.7	0.110	0.054
(7 x 0.75 ²)	(18 / 7c)	48021	11.1	0.185	0.094
(12 x 0.75 ²)	(18 / 12c)	48022	12.6	0.250	0.138
(18 x 0.75 ²)	(18 / 18c)	48023	14.6	0.355	0.223
(25 x 0.75 ²)	(18 / 25c)	48024	18.5	0.520	0.298
(4 x 1 ²)	(17 / 4c)	48025	9.3	0.130	0.066
(7 x 1 ²)	(17 / 7c)	48026	11.9	0.218	0.113
(12 x 1 ²)	(17 / 12c)	48027	13.8	0.304	0.199
(18 x 1 ²)	(17 / 18c)	48028	16.1	0.438	0.262
(25 x 1 ²)	(17 / 25c)	48029	20.5	0.609	0.352
(4 x 1.5 ²)	(16 / 4c)	48030	9.7	0.150	0.086
(7 x 1.5 ²)	(16 / 7c)	48031	12.8	0.270	0.155
(12 x 1.5 ²)	(16 / 12c)	48032	15.1	0.406	0.257
(18 x 1.5 ²)	(16 / 18c)	48033	18.0	0.575	0.363
(25 x 1.5 ²)	(16 / 25c)	48034	22.5	0.780	0.502





Core insulation
KS-PVC
bundled stranding
(> 8 cores)



Outer jacket
KS-PVC
valley-sealed extruded
hi-flex design
UV-resistant
very abrasion-resistant



Jacket color
co-extruded
ICC color identification
based on
DESINA color code

LIFE-LINE Control 400

Unshielded continuous bending hi-flex PVC control cables

Up to
4 million
motion cycles!

Up to
50 m
travel length!

LIFE-LINE
cables for
cable carriers

ICC
KABELSCHLEPP
Integrated Colour Code

RoHS
conform

Developed for

- systems engineering and mechanical engineering
- crane and conveyor equipment
- monitoring, measuring and control cables
- medium to heavy loads

Properties

- oil-resistant
- UV-resistant
- RoHS-conform
- CFC-free
- silicone-free
- flame-retardant

Design

Conductor:	finely stranded bare copper wires in an optimized hi-flex design
Center element:	type-dependent
Core insulation:	KS-PVC
Core identification:	black with white numbers, protective conductor green/yellow
Core stranding:	conductor cores bundled in short pitches with minimal torsion (> 8 cores) conductor cores layered in short pitches with minimal torsion (≤ 8 cores)
Outer jacket:	KS-PVC
Jacket color:	black with ICC color identification based on the DESINA color code

Technical Data

Temperature range:	- 5 to + 80 °C
Minimum bend radius while moved*:	$KR_{min} \geq 7.5 \times \varnothing$
v_{max} unsupported:	10 m/s
v_{max} gliding:	5 m/s
a_{max}:	20 m/s ²
Insulation resistance:	≥ 10 MΩ x km
Rated voltage:	according to VDE 300/500V, < 0.5 ² 300/300V according to UL 300V
Approvals:	UL, CSA (type-dependent), based on VDE

* smaller bend radii are suitable in a wide range of applications – please contact us

Type selection

LIFE-LINE Control 400 – UNSHIELDED

core number x nominal-cross-section in mm ²	conductor cross section AWG (approximate values)	article number	max OD in mm	weight kg/m	Cu index kg/m
4 x 0.34 ²	22 / 4c	48373	5.7	0.038	0.013
3 x 0.5 ²	20 / 3c	48111	5.7	0.039	0.014
4 x 0.5 ²	20 / 4c	48112	6.2	0.049	0.019
5 x 0.5 ²	20 / 5c	48113	6.7	0.069	0.025
7 x 0.5 ²	20 / 7c	48115	7.9	0.078	0.034
12 x 0.5 ²	20 / 12c	48119	11.2	0.165	0.063
18 x 0.5 ²	20 / 18c	48121	13.5	0.215	0.087
25 x 0.5 ²	20 / 25c	48124	15.0	0.310	0.130
30 x 0.5 ²	20 / 30c	48125	18.3	0.380	0.155
36 x 0.5 ²	20 / 36c	48126	19.9	0.480	0.185
48 x 0.5 ²	20 / 48c	48128	22.5	0.690	0.260
4 x 0.75 ²	18 / 4c	48040	6.5	0.061	0.029
5 x 0.75 ²	18 / 5c	48041	7.1	0.073	0.036
7 x 0.75 ²	18 / 7c	48042	8.8	0.110	0.051
12 x 0.75 ²	18 / 12c	48043	11.9	0.205	0.088
18 x 0.75 ²	18 / 18c	48044	14.5	0.290	0.138
25 x 0.75 ²	18 / 25c	48045	17.5	0.415	0.195
3 x 1 ²	17 / 3c	48046	6.3	0.059	0.029
4 x 1 ²	17 / 4c	48047	7.1	0.078	0.039
5 x 1 ²	17 / 5c	48048	7.5	0.088	0.050
7 x 1 ²	17 / 7c	48049	9.7	0.140	0.068
12 x 1 ²	17 / 12c	48050	13.1	0.260	0.125
18 x 1 ²	17 / 18c	48051	17.0	0.395	0.187
25 x 1 ²	17 / 25c	48052	18.9	0.520	0.260
3 x 1.5 ²	16 / 3c	48053	7.2	0.086	0.045
4 x 1.5 ²	16 / 4c	48054	7.7	0.097	0.058
5 x 1.5 ²	16 / 5c	48055	8.8	0.130	0.072
7 x 1.5 ²	16 / 7c	48056	10.6	0.175	0.101
12 x 1.5 ²	16 / 12c	48057	14.2	0.325	0.174
18 x 1.5 ²	16 / 18c	48058	18.7	0.480	0.280
25 x 1.5 ²	16 / 25c	48059	21.4	0.690	0.360
30 x 1.5 ²	16 / 30c	48580	23.7	0.880	0.473
4 x 2.5 ²	14 / 4c	48060	9.5	0.176	0.101





Core insulation
KS-PVC
bundled stranding
(> 8 cores)



Inner jacket
KS-PVC
valley-sealed,
pressure extruded,
hi-flex design



Overall shield
continuous bending hi-flex,
tin-plated copper braiding
for smallest bend radii
Coverage: approx. 80 %



Outer jacket
KS-PVC
pressure extruded
hi-flex design
UV-resistant
very abrasion-resistant



Jacket color
co-extruded
ICC color identification
based on
DESINA color code

LIFE-LINE Control 400 C

Shielded continuous bending hi-flex PVC control cables



Up to
4 million
motion cycles!



Up to
50 m
travel length!

LIFE-LINE
cables for
cable carriers

ICC
KABELSCHLEPP
Integrated Colour Code

RoHS
conform

Developed for

- systems engineering and mechanical engineering
- crane and conveyor equipment
- monitoring, measuring and control cables
- medium to heavy loads

Properties

- oil-resistant
- UV-resistant
- RoHS-conform
- CFC-free
- silicone-free
- flame-retardant

Design

Conductor:	finely stranded bare copper wires in an optimized hi-flex design
Center element:	type-dependent
Core insulation:	KS-PVC
Core identification:	black with white numbers, protective conductor green/yellow core cross section $\leq 0,34 \text{ mm}^2$: core identification according to DIN 47100
Core stranding:	conductor cores bundled in short pitches with minimal torsion (> 8 cores) conductor cores layered in short pitches with minimal torsion (≤ 8 cores)
Shielding:	coverage 80 %
Outer jacket:	KS-PVC
Jacket color:	black with ICC color identification based on the DESINA color code
Inner jacket:	KS-PVC

Technical Data

Temperature range:	-5 to +80 °C
Minimum bend radius while moved*:	$KR_{\min} \geq 7,5 \times \varnothing$
v_{max} unsupported:	10 m/s
v_{max} gliding:	5 m/s
a_{max}:	20 m/s ²
Insulation resistance:	$\geq 10 \text{ M}\Omega \times \text{km}$
Rated voltage:	according to VDE 300/500V according to UL 300V
Approvals:	UL, CSA (type-dependent), based on VDE

* smaller bend radii are suitable in a wide range of applications – please contact us

Type selection

LIFE-LINE Control 400 C – SHIELDED

core number x nominal-cross-section in mm ²	conductor cross section AWG (approximate values)	article number	max OD in mm	weight kg/m	Cu index kg/m
(4 x 0.25 ²)	24 / 4c	48623	7.3	0.067	0.029
(8 x 0.25 ²)	24 / 8c	48627	9.6	0.125	0.056
(25 x 0.25 ²)	24 / 25c	48638	16.0	0.330	0.134
(4 x 0.34 ²)	22 / 4c	48647	7.6	0.086	0.041
(5 x 0.34 ²)	22 / 5c	48648	8.4	0.104	0.046
(7 x 0.34 ²)	22 / 7c	48649	9.7	0.129	0.058
(5 x 0.5 ²)	20 / 5c	48664	8.7	0.110	0.052
(7 x 0.5 ²)	20 / 7c	48666	10.0	0.140	0.066
(9 x 0.5 ²)	20 / 9c	48668	12.0	0.198	0.090
(12 x 0.5 ²)	20 / 12c	48670	12.7	0.240	0.106
(18 x 0.5 ²)	20 / 18c	48674	15.7	0.340	0.169
(25 x 0.5 ²)	20 / 25c	48678	18.0	0.455	0.223
(30 x 0.5 ²)	20 / 30c	48679	21.3	0.633	0.272
(36 x 0.5 ²)	20 / 36c	48680	23.8	0.745	0.302
(3 x 0.75 ²)	(18 / 3c)	48682	7.8	0.087	0.045
(4 x 0.75 ²)	(18 / 4c)	48070	8.7	0.122	0.055
(7 x 0.75 ²)	(18 / 7c)	48071	11.0	0.175	0.085
(12 x 0.75 ²)	(18 / 12c)	48072	13.9	0.300	0.151
(18 x 0.75 ²)	(18 / 18c)	48073	18.4	0.476	0.225
(25 x 0.75 ²)	(18 / 25c)	48074	21.2	0.630	0.295
(4 x 1 ²)	(17 / 4c)	48075	9.2	0.135	0.073
(7 x 1 ²)	(17 / 7c)	48076	11.9	0.220	0.115
(12 x 1 ²)	(17 / 12c)	48077	15.5	0.380	0.198
(18 x 1 ²)	(17 / 18c)	48078	18.5	0.495	0.272
(25 x 1 ²)	(17 / 25c)	48079	23.1	0.766	0.357
(4 x 1.5 ²)	(16 / 4c)	48080	9.9	0.150	0.085
(5 x 1.5 ²)	(16 / 5c)	48081	10.4	0.180	0.103
(7 x 1.5 ²)	(16 / 7c)	48082	12.4	0.250	0.148
(12 x 1.5 ²)	(16 / 12c)	48083	17.5	0.485	0.269
(18 x 1.5 ²)	(16 / 18c)	48084	21.8	0.708	0.382
(25 x 1.5 ²)	(16 / 25c)	48085	25.2	0.960	0.503
(30 x 1.5 ²)	(16 / 30c)	48086	27.1	1.150	0.635





Core insulation
KS-PP/TPE
bundled stranding
(> 8 cores)



Outer jacket
KS-PUR
valley-sealed extruded
hi-flex design
UV-resistant
extremely abrasion-resistant



Jacket color
co-extruded
ICC color identification
based on
DESINA color code

LIFE-LINE Control 700

Unshielded continuous bending hi-flex PUR control cables

Up to
7 million
motion cycles!

Up to
500 m
travel length!

LIFE-LINE
cables for
cable carriers

ICC
KABELSCHLEPP
Integrated Colour Code

RoHS
conform

Developed for

- systems engineering and mechanical engineering
- crane and conveyor equipment
- monitoring, measuring and control cables
- extremely heavy loads

Properties

- oil-resistant
- UV-resistant
- RoHS-conform
- halogen-free
- CFC-free
- silicone-free
- flame-retardant

Design

Conductor: extremely fine stranded conductors of bare copper wires in an optimized hi-flex design

Center element: type-dependent

Core insulation: KS-PP/TPE

Core identification: black with white numbers, protective conductor green/yellow, single-core: black
core cross section $\leq 0.34 \text{ mm}^2$:
core identification according to DIN 47100

Core stranding: conductor cores bundled in short pitches with minimal torsion (> 8 cores)
conductor cores layered in short pitches with minimal torsion (≤ 8 cores)

Outer jacket: KS-PUR

Jacket color: black with ICC color identification based on the DESINA color code (grey type-dependent)

Technical Data

Temperature range: -30 to $+90$ °C

Minimum bend radius while moved*: $KR_{\min} \geq 7.5 \times \varnothing$

v_{max} unsupported: 20 m/s

v_{max} gliding: 5 m/s

a_{max}: 50 m/s²

Insulation resistance: $\geq 30 \text{ M}\Omega \times \text{km}$

Rated voltage: according to VDE 300/500V, < 0.52 300/300V according to UL 300V

Approvals: UL, CSA, based on VDE

* smaller bend radii are suitable in a wide range of applications – please contact us



Type selection

LIFE-LINE Control 700 – UNSHIELDED

core number x nominal-cross-section in mm ²	conductor cross section AWG (approximate values)	article number	max OD in mm	weight kg/m	Cu index kg/m
1 x 0.25 ²	24 / 1c	45350	2.6	0.008	0.002
1 x 0.34 ²	22 / 1c	45370	3.9	0.018	0.003
4 x 0.34 ²	22 / 4c	45373	5.6	0.037	0.014
5 x 0.34 ²	22 / 5c	45374	6.0	0.045	0.017
7 x 0.34 ²	22 / 7c	45376	7.1	0.067	0.024
8 x 0.34 ²	22 / 8c	45377	7.8	0.070	0.027
12 x 0.34 ²	22 / 12c	45380	9.5	0.115	0.041
15 x 0,34 ²	22 / 15c	45382	9.8	0.122	0.053
1 x 0.5 ²	20 / 1c	45390	4.1	0.021	0.005
2 x 0.5 ²	20 / 2c	45391	5.8	0.040	0.010
3 x 0.5 ²	20 / 3c	45392	6.1	0.047	0.014
4 x 0.5 ²	20 / 4c	45393	6.3	0.051	0.020
7 x 0.5 ²	20 / 7c	45396	8.1	0.080	0.035
12 x 0.5 ²	20 / 12c	45400	10.0	0.140	0.060
36 x 0,5 ²	21 / 36c	45412	17.2	0.397	0.198
1 x 0.75 ²	18 / 1c	45419	4.3	0.024	0.007
3 x 0.75 ²	18 / 3c	45421	6.3	0.053	0.023
4 x 0.75 ²	18 / 4c	45422	6.7	0.064	0.031
5 x 0.75 ²	18 / 5c	45423	7.4	0.076	0.038
7 x 0.75 ²	18 / 7c	45425	8.7	0.105	0.053
12 x 0.75 ²	18 / 12c	45429	11.0	0.185	0.096
18 x 0.75 ²	18 / 18c	45431	13.6	0.260	0.146
25 x 0.75 ²	18 / 25c	45434	15.4	0.350	0.209
36 x 0.75 ²	18 / 36c	45436	19.8	0.513	0.270
1 x 1 ²	17 / 1c	45439	4.5	0.027	0.010
3 x 1 ²	17 / 3c	45441	6.7	0.065	0.029
4 x 1 ²	17 / 4c	45442	7.1	0.080	0.044
5 x 1 ²	17 / 5c	45443	7.7	0.095	0.056
7 x 1 ²	17 / 7c	45445	10.2	0.125	0.070
8 x 1 ²	17 / 8c	45446	10.7	0.139	0.077
12 x 1 ²	17 / 12c	45449	11.8	0.225	0.125
18 x 1 ²	17 / 18c	45451	14.6	0.330	0.210
25 x 1 ²	17 / 25c	45454	17.0	0.445	0.302
7 x 1.5 ²	16 / 7c	45477	10.2	0.160	0.105
12 x 1.5 ²	16 / 12c	45480	13.5	0.296	0.195
18 x 2.5 ²	14 / 18c	45497	21.2	0.700	0.450
25 x 2.5 ²	14 / 25c	45498	24.0	0.915	0.625



Subject to change.

Additional cable types upon request.

LIFE-LINE Control 700 C

Shielded continuous bending hi-flex PUR control cables

kabelschlepp.de

Questions about cable carrier cables? Fon: +49 2762 4003-0

Picture obtainable.



Core insulation
KS-PP/TPE
bundled stranding
(> 8 cores)



Inner jacket
KS-PUR
valley-sealed,
pressure extruded,
hi-flex design



Overall shield
continuous bending hi-flex,
tin-plated copper braiding
for smallest bend radii
Coverage: approx. 85 %



Outer jacket
KS-PUR
pressure extruded
hi-flex design
UV-resistant
extremely abrasion-resistant



Jacket color
co-extruded
ICC color identification
based on
DESINA color code



Up to
7 million
motion cycles!



Up to
500 m
travel length!

LIFE-LINE
cables for
cable carriers

ICC
KABELSCHLEPP
Integrated Colour Code

RoHS
conform ✓

Developed for

- systems engineering and mechanical engineering
- crane and conveyor equipment
- monitoring, measuring and control cables
- extremely heavy loads

Properties

- oil-resistant
- UV-resistant
- RoHS-conform
- halogen-free
- CFC-free
- silicone-free
- flame-retardant

Design

Conductor:	extremely fine stranded conductors of bare copper wires in an optimized hi-flex design
Center element:	type-dependent
Core insulation:	KS-PP/TPE
Core identification:	black with white numbers, protective conductor green/yellow article number 45844: core identification according to DIN 47100
Core stranding:	conductor cores bundled in short pitches with minimal torsion (> 8 cores) conductor cores layered in short pitches with minimal torsion (≤ 8 cores)
Shielding:	coverage 85 %
Outer jacket:	KS-PUR
Jacket color:	black with ICC color identification based on the DESINA color code (grey type-dependent)
Inner jacket:	KS-PUR

Technical Data

Temperature range:	- 30 to + 90 °C
Minimum bend radius while moved*:	KR _{min} ≥ 7.5 x Ø
v_{max} unsupported:	20 m/s
v_{max} gliding:	5 m/s
a_{max}:	50 m/s ²
Insulation resistance:	≥ 30 MΩ x km
Rated voltage:	according to VDE 300/500V, < 0.5 ² 300/300V according to UL 300V
Approvals:	UL, CSA, based on VDE

* smaller bend radii are suitable in a wide range of applications – please contact us



Type selection

LIFE-LINE Control 700 C – SHIELDED

core number x nominal-cross-section in mm ²	conductor cross section AWG (approximate values)	article number	max OD in mm	weight kg/m	Cu index kg/m
(7 x 0.34 ²)	(22 / 7c)	45844	9.2	0.119	0.053
(3 x 0.5 ²)	(20 / 3c)	45701	7.5	0.076	0.033
(4 x 0.5 ²)	(20 / 4c)	45702	8.4	0.085	0.040
(5 x 0.5 ²)	(20 / 5c)	45703	8.5	0.100	0.051
(7 x 0.5 ²)	(20 / 7c)	45705	9.4	0.138	0.068
(12 x 0.5 ²)	(20 / 12c)	45709	12.0	0.205	0.109
(18 x 0.5 ²)	(20 / 18c)	45712	14.4	0.275	0.167
(25 x 0.5 ²)	(20 / 25c)	45715	16.4	0.360	0.212
(3 x 0.75 ²)	(18 / 3c)	45721	8.4	0.092	0.042
(4 x 0.75 ²)	(18 / 4c)	45722	8.9	0.115	0.055
(5 x 0.75 ²)	(18 / 5c)	45723	9.2	0.125	0.068
(7 x 0.75 ²)	(18 / 7c)	45725	10.4	0.150	0.087
(12 x 0.75 ²)	(18 / 12c)	45729	13.0	0.255	0.147
(18 x 0.75 ²)	(18 / 18c)	45732	15.8	0.350	0.222
(25 x 0.75 ²)	(18 / 25c)	45735	18.7	0.515	0.293
(3 x 1 ²)	(17 / 3c)	45741	8.6	0.110	0.059
(4 x 1 ²)	(17 / 4c)	45742	9.1	0.126	0.070
(5 x 1 ²)	(17 / 5c)	45743	9.6	0.145	0.086
(7 x 1 ²)	(17 / 7c)	45745	11.2	0.195	0.112
(12 x 1 ²)	(17 / 12c)	45749	13.8	0.305	0.187
(18 x 1 ²)	(17 / 18c)	45752	17.8	0.465	0.298
(25 x 1 ²)	(17 / 25c)	45755	19.5	0.610	0.389





Core insulation
KS-PP/TPE
bundled stranding
(> 8 cores)



Outer jacket
KS-PVC
valley-sealed extruded
hi-flex design
UV-resistant
very abrasion-resistant

LIFE-LINE Power 400

Unshielded continuous bending hi-flex PVC power cables

Up to
4 million
motion cycles!

Up to
50 m
travel length!

LIFE-LINE

cables for
cable carriers

RoHS
conform

Developed for

- systems engineering and mechanical engineering
- crane and conveyor equipment
- power and supply cable
- medium to heavy loads

Properties

- oil-resistant
- UV-resistant
- RoHS-conform
- CFC-free
- silicone-free
- flame-retardant
- based on DESINA color code

Design

Conductor:	extremely fine stranded conductors of bare copper wires in an optimized hi-flex design
Center element:	type-dependent
Core insulation:	KS-PP/TPE
Core identification:	black with white numbers, protective conductor green/yellow
Core stranding:	conductor cores bundled in short pitches with minimal torsion (> 8 cores) conductor cores layered in short pitches with minimal torsion (≤ 8 cores)
Outer jacket:	KS-PVC
Jacket color:	black (according to DESINA)

Technical Data

Temperature range:	- 5 to + 80 °C
Minimum bend radius while moved*:	$KR_{min} \geq 7.5 \times \varnothing$
v_{max} unsupported:	5 m/s
v_{max} gliding:	3 m/s
a_{max}:	20 m/s ²
Insulation resistance:	≥ 30 MΩ x km
Rated voltage:	according to VDE 0.6/1kV according to UL 1kV

Approvals: UL, CSA, based on VDE

* smaller bend radii are suitable in a wide range of applications – please contact us

Type selection

LIFE-LINE Power 400 – UNSHIELDED

core number x nominal-cross-section in mm ²	conductor cross section AWG (approximate values)	article number	max OD in mm	weight kg/m	Cu index kg/m
3 x 1.5 ²	16 / 3c	45201	7.0	0.079	0.045
4 x 1.5 ²	16 / 4c	45202	7.9	0.096	0.060
5 x 1.5 ²	16 / 5c	45203	8.8	0.125	0.072
7 x 1.5 ²	16 / 7c	45205	10.4	0.175	0.105
12 x 1.5 ²	16 / 12c	45209	14.2	0.325	0.180
18 x 1.5 ²	16 / 18c	45211	18.0	0.460	0.270
25 x 1.5 ²	16 / 25c	45214	21.9	0.680	0.405
4 x 2.5 ²	14 / 4c	45222	9.3	0.150	0.100
5 x 2.5 ²	14 / 5c	45223	10.4	0.180	0.125
7 x 2.5 ²	14 / 7c	45225	12.5	0.265	0.168
12 x 2.5 ²	14 / 12c	45229	18.3	0.500	0.300
18 x 2.5 ²	14 / 18c	45231	23.1	0.755	0.450
25 x 2.5 ²	14 / 25c	45234	26.4	1.020	0.625
4 x 4 ²	12 / 4c	45242	11.3	0.230	0.160
5 x 4 ²	12 / 5c	45243	12.3	0.280	0.200
7 x 4 ²	12 / 7c	45245	14.7	0.390	0.280
4 x 6 ²	10 / 4c	45252	13.4	0.335	0.240
5 x 6 ²	10 / 5c	45253	14.8	0.406	0.288
7 x 6 ²	10 / 7c	45254	17.9	0.575	0.420
4 x 10 ²	8 / 4c	45262	16.6	0.530	0.400
5 x 10 ²	8 / 5c	45263	18.4	0.647	0.480
4 x 16 ²	6 / 4c	45272	20.6	0.805	0.640
4 x 25 ²	4 / 4c	45282	25.6	1.270	1.000
4 x 35 ²	2 / 4c	45292	29.4	1.770	1.400





Core insulation
KS-PP/TPE
bundled stranding
(> 8 cores)



Inner jacket
KS-PVC
valley-sealed,
pressure extruded,
hi-flex design



Overall shield
continuous bending hi-flex,
tin-plated copper braiding
for smallest bend radii
Coverage: approx. 80 %



Outer jacket
KS-PVC
pressure extruded
hi-flex design
UV-resistant
very abrasion-resistant



Jacket color
co-extruded
ICC color identification
based on
DESINA color code

LIFE-LINE Power 400 C

Shielded continuous bending hi-flex PVC power cables

Up to
4 million
motion cycles!

Up to
50 m
travel length!

LIFE-LINE
cables for
cable carriers

ICC
KABELSCHLEPP
Integrated Colour Code

RoHS
conform

Developed for

- systems engineering and mechanical engineering
- crane and conveyor equipment
- power and supply cable
- medium to heavy loads

Properties

- oil-resistant
- UV-resistant
- RoHS-conform
- CFC-free
- silicone-free
- flame-retardant

Design

Conductor:	extremely fine stranded conductors of bare copper wires in an optimized hi-flex design
Center element:	type-dependent
Core insulation:	KS-PP
Core identification:	black with white numbers, protective conductor green/yellow
Core stranding:	conductor cores bundled in short pitches with minimal torsion (> 8 cores) conductor cores layered in short pitches with minimal torsion (≤ 8 cores)
Shielding:	coverage 80 %
Outer jacket:	KS-PVC
Jacket color:	black with ICC color identification based on the DESINA color code
Inner jacket:	KS-PVC

Technical Data

Temperature range:	- 5 to + 80 °C
Minimum bend radius while moved*:	$KR_{min} \geq 7.5 \times \varnothing$
v_{max} unsupported:	5 m/s
v_{max} gliding:	3 m/s
a_{max}:	20 m/s ²
Insulation resistance:	≥ 30 MΩ x km
Rated voltage:	according to VDE 0.6/1kV according to UL 1kV
Approvals:	UL, CSA, based on VDE

* smaller bend radii are suitable in a wide range of applications – please contact us



Type selection

LIFE-LINE Power 400 C – SHIELDED

core number x nominal-cross-section in mm ²	conductor cross section AWG (approximate values)	article number	max OD in mm	weight kg/m	Cu index kg/m
(4 x 1.5 ²)	(16 / 4c)	47202	10.2	0.160	0.104
(4 x 2.5 ²)	(14 / 4c)	47222	11.9	0.230	0.148
(5 x 2.5 ²)	(14 / 5c)	47223	12.7	0.265	0.171
(7 x 2.5 ²)	(14 / 7c)	47225	14.8	0.360	0.235
(4 x 4 ²)	(12 / 4c)	47242	13.7	0.315	0.209
(4 x 6 ²)	(10 / 4c)	47252	16.1	0.445	0.307
(4 x 10 ²)	(8 / 4c)	47262	20.2	0.735	0.520
(4 x 16 ²)	(6 / 4c)	47272	23.9	1.020	0.767
(4 x 25 ²)	(4 / 4c)	47282	28.6	1.530	1.163





Core insulation
KS-PP/TPE
bundled stranding
(> 8 cores)



Outer jacket
KS-PUR
valley-sealed extruded
hi-flex design
UV-resistant
extremely abrasion-resistant

LIFE-LINE Power 700 / 700 PE/3

Unshielded continuous bending hi-flex PUR power cables

Up to
7 million
motion cycles!

Up to
500 m
travel length!

LIFE-LINE
cables for
cable carriers

RoHS
conform

Developed for

- systems engineering and mechanical engineering
- crane and conveyor equipment
- power and supply cable
- extremely heavy loads

Properties

- oil-resistant
- UV-resistant
- RoHS-conform
- halogen-free
- CFC-free
- silicone-free
- flame-retardant

Design

Conductor:	extremely fine stranded conductors of bare copper wires in an optimized hi-flex design
Center element:	type-dependent
Core insulation:	KS-PP/TPE
Core identification:	black with white numbers, protective conductor green/yellow
Core stranding:	conductor cores bundled in short pitches with minimal torsion (> 8 cores) conductor cores layered in short pitches with minimal torsion (≤ 8 cores)
Outer jacket:	KS-PUR
Jacket color:	black (according to DESINA)

Technical Data

Temperature range:	- 30 to + 90 °C
Minimum bend radius while moved*:	$KR_{min} \geq 7,5 \times \varnothing$
v_{max} unsupported:	20 m/s
v_{max} gliding:	5 m/s
a_{max}:	50 m/s ²
Insulation resistance:	≥ 30 MΩ x km
Rated voltage:	according to VDE 0.6/1kV according to UL 1kV

Approvals: UL, CSA, based on VDE

* smaller bend radii are suitable in a wide range of applications – please contact us



Type selection

LIFE-LINE Power 700 – UNSHIELDED

core number x nominal-cross-section in mm ²	conductor cross section AWG (approximate values)	article number	max OD in mm	weight kg/m	Cu index kg/m
3 x 1.5 ²	16 / 3c	45501	7.8	0.087	0.045
4 x 1.5 ²	16 / 4c	45502	8.5	0.110	0.058
5 x 1.5 ²	16 / 5c	45503	9.2	0.130	0.072
7 x 1.5 ²	16 / 7c	45505	10.7	0.175	0.105
12 x 1.5 ²	16 / 12c	45509	14.2	0.320	0.195
18 x 1.5 ²	16 / 18c	45511	18.0	0.455	0.270
25 x 1.5 ²	16 / 25c	45514	21.2	0.650	0.405
36 x 1.5 ²	16 / 36c	45516	26.2	0.970	0.540
3 x 2.5 ²	14 / 3c	45521	9.0	0.125	0.075
4 x 2.5 ²	14 / 4c	45522	9.7	0.155	0.108
5 x 2.5 ²	14 / 5c	45523	10.8	0.185	0.125
7 x 2.5 ²	14 / 7c	45525	12.6	0.260	0.175
12 x 2.5 ²	14 / 12c	45529	17.8	0.490	0.300
18 x 2.5 ²	14 / 18c	45531	23.0	0.745	0.450
25 x 2.5 ²	14 / 25c	45534	26.5	1.000	0.625
36 x 2.5 ²	14 / 36c	45536	31.2	1.390	0.900
3 x 4 ²	12 / 3c	45541	10.3	0.180	0.120
4 x 4 ²	12 / 4c	45542	11.3	0.230	0.154
5 x 4 ²	12 / 5c	45544	13.4	0.240	0.240
7 x 4 ²	12 / 7c	45543	14.7	0.385	0.280
3 x 6 ²	10 / 3c	45551	12.4	0.270	0.173
4 x 6 ²	10 / 4c	45552	13.4	0.330	0.240
5 x 6 ²	10 / 5c	45553	14.8	0.400	0.300
7 x 6 ²	10 / 7c	45555	17.8	0.555	0.404
4 x 10 ²	8 / 4c	45562	16.6	0.530	0.384
5 x 10 ²	8 / 5c	45563	18.1	0.650	0.500
4 x 16 ²	6 / 4c	45565	20.7	0.820	0.640
5 x 16 ²	6 / 5c	45566	23.6	1.050	0.800
4 x 25 ²	4 / 4c	45568	25.8	1.250	1.000
5 x 25 ²	5 / 4c	45569	28.4	1.580	1.200
3 x 35 ²	2 / 3c	45570	26.2	1.355	1.008
4 x 35 ²	2 / 4c	45571	29.6	1.750	1.344
5 x 35 ²	2 / 5c	45560	32.5	2.400	1.750
4 x 50 ²	1 / 4c	45572	33.6	2.280	1.920
4 x 70 ²	2 / 0 / 4c	45573	42.8	3.200	2.700
4 x 95 ²	3 / 0 / 4c	45574	46.0	4.450	3.800

LIFE-LINE Power 700 PE/3 – UNSHIELDED

core number x nominal-cross-section in mm ²	conductor cross section AWG (approximate values)	article number	max OD in mm	weight kg/m	Cu index kg/m
3 x 25 ² + 3 x 6 ² PE	(4 / 3c + 10 / 3c)	45852	22.4	1.112	0.930
3 x 35 ² + 3 x 6 ² PE	(2 / 3c + 10 / 3c)	45853	26.4	1.630	1.230
3 x 50 ² + 3 x 10 ² PE	(1 / 3c + 8 / 3c)	45854	30.8	2.120	1.836
3 x 70 ² + 3 x 16 ² PE	(2 / 3c + 6 / 3c)	45855	37.8	3.275	2.580
3 x 95 ² + 3 x 16 ² PE	(3 / 3c + 6 / 3c)	45856	42.5	3.875	3.330



Subject to change.

Additional cable types upon request.

kabelschlepp.de

Questions about cable carrier cables? Fon: +49 2762 4003-0

BASIC
LINEPLUS

VARIO
LINE

TUBE
SERIES

3D
LINE

STEEL
LINE

Order

LIFE-LINE Safety Cables
TOTALTRAX Complete Systems



(Krombach) LIFE-LINE SAFETY CABLES
TOTALTRAX COMPLETE SYSTEMS



Core insulation
KS-PP/TPE
wire bundles
in very short pitches



Outer jacket
KS-PUR
pressure extruded
hi-flex design
UV-resistant
extremely abrasion-resistant

LIFE-LINE Power ONE 700

Unshielded continuous bending hi-flex PUR single-core cables

Up to
7 million
motion cycles!

Up to
500 m
travel length!

LIFE-LINE
cables for
cable carriers

RoHS
conform

Developed for

- systems engineering and mechanical engineering
- crane and conveyor equipment
- power and supply cable
- extremely heavy loads

Properties

- oil-resistant
- UV-resistant
- RoHS-conform
- halogen-free
- CFC-free
- silicone-free
- flame-retardant

Design

Conductor:	extremely fine stranded conductors of bare copper wires in an optimized hi-flex design
Core insulation:	KS-PP/TPE
Core stranding:	single-core
Outer jacket:	KS-PUR
Jacket color:	black (according to DESINA)

Technical Data

Temperature range:	- 30 to + 90 °C
Minimum bend radius while moved*:	$KR_{min} \geq 7.5 \times \varnothing$
v_{max} unsupported:	20 m/s
v_{max} gliding:	5 m/s
a_{max}:	50 m/s ²
Insulation resistance:	≥ 30 MΩ x km
Rated voltage:	according to VDE 0,6/1kV according to UL 1kV

Approvals:	UL, CSA, based on VDE
-------------------	-----------------------------

* smaller bend radii are suitable in a wide range of applications – please contact us

Type selection

LIFE-LINE Power ONE 700 – UNSHIELDED

core number x nominal-cross-section in mm ²	conductor cross section AWG (approximate values)	article number	max OD in mm	weight kg/m	Cu index kg/m
1 x 1.5 ²	16 / 1c	45580	5.2	0.036	0.014
1 x 2.5 ²	14 / 1c	45581	5.7	0.045	0.025
1 x 4 ²	12 / 1c	45582	6.3	0.061	0.040
1 x 6 ²	10 / 1c	45583	7.2	0.085	0.060
1 x 10 ²	8 / 1c	45584	8.5	0.130	0.100
1 x 16 ²	6 / 1c	45585	10.0	0.195	0.154
1 x 25 ²	4 / 1c	45586	11.8	0.280	0.240
1 x 35 ²	2 / 1c	45587	12.9	0.385	0.350
1 x 50 ²	1 / 1c	45588	14.6	0.520	0.500
1 x 70 ²	2 / 0 / 1c	45589	17.2	0.810	0.700
1 x 95 ²	3 / 0 / 1c	45590	19.5	0.950	0.950
1 x 120 ²	4 / 0 / 1c	45591	23.6	1.315	1.200
1 x 150 ²	250 MCM / 1c	45592	24.9	1.510	1.500
1 x 185 ²	350 MCM / 1c	45593	27.6	1.960	1.850
1 x 240 ²	400 MCM / 1c	45594	30.0	2.530	2.304
1 x 300 ²	500 MCM / 1c	45595	33.8	3.180	2.880
1 x 400 ²	800 MCM / 1c	45596	40.2	4.210	3.800
1 x 500 ²	1000 MCM / 1c	45597	42.9	5.140	5.000



Power ONE
700 PE

kabelschlepp.de

Questions about cable carrier cables? Fon: +49 2762 4003-0

Picture obtainable.



© Kabelschlepp GmbH
LIFE-LINE Safety Cables
TOTALTRAX Complete Systems



Core insulation
KS-PP/TPE
wire bundles
in very short pitches



Outer jacket
KS-PUR
pressure extruded
hi-flex design
UV-resistant
extremely abrasion-resistant

LIFE-LINE Power ONE 700 PE

Unshielded, continuous bending highly-flexible PUR single-core cables with PE core identification

Up to
7 million
motion cycles!

Up to
500 m
travel length!

LIFE-LINE
cables for
cable carriers

RoHS
conform

Developed for

- systems engineering and mechanical engineering
- crane and conveyor equipment
- power and supply cable
- extremely heavy loads

Properties

- oil-resistant
- UV-resistant
- RoHS-conform
- halogen-free
- CFC-free
- silicone-free
- flame-retardant

Design

Conductor:	extremely fine stranded conductors of bare copper wires in an optimized hi-flex design
Core insulation:	KS-PP/TPE
Core identification:	green/yellow
Core stranding:	single-core
Outer jacket:	KS-PUR
Jacket color:	black

Technical Data

Temperature range:	- 30 to + 90 °C
Minimum bend radius while moved*:	$KR_{min} \geq 7,5 \times \varnothing$
v_{max} unsupported:	20 m/s
v_{max} gliding:	5 m/s
a_{max}:	50 m/s ²
Insulation resistance:	$\geq 30 \text{ M}\Omega \times \text{km}$
Rated voltage:	according to VDE 0.6/1kV according to UL/CSA 80 °C 1kV

Approvals: UL, CSA, based on VDE

* smaller bend radii are suitable in a wide range of applications – please contact us

Type selection

LIFE-LINE Power ONE 700 PE – UNSHIELDED

core number x nominal-cross-section in mm ²	conductor cross section AWG (approximate values)	article number	max OD in mm	weight kg/m	Cu index kg/m
1 x 4 ²	12 / 1c	47582	6.3	0.061	0.040
1 x 6 ²	10 / 1c	47583	7.2	0.085	0.060
1 x 10 ²	8 / 1c	47584	8.5	0.130	0.100
1 x 16 ²	6 / 1c	47585	10.0	0.195	0.154
1 x 25 ²	4 / 1c	47586	11.8	0.280	0.240
1 x 35 ²	2 / 1c	47587	12.9	0.385	0.350
1 x 50 ²	0 / 1c	47588	14.6	0.520	0.500



Picture obtainable.



Core insulation
KS-PP/TPE
bundled stranding
(> 8 cores)



Inner jacket
KS-PUR
valley-sealed,
pressure extruded,
hi-flex design



Overall shield
continuous bending hi-flex,
tin-plated copper braiding
for smallest bend radii
Coverage: approx. 85 %



Outer jacket
KS-PUR
pressure extruded
hi-flex design
UV-resistant
extremely abrasion-resistant



Jacket color
co-extruded
ICC color identification
based on
DESINA color code

LIFE-LINE Power 700 C / 700 C PE/3

Shielded continuous bending hi-flex PUR power cables

Up to **7 million** motion cycles!

Up to **500 m** travel length!



Developed for

- systems engineering and mechanical engineering
- crane and conveyor equipment
- power and supply cable
- extremely heavy loads

Properties

- oil-resistant
- UV-resistant
- RoHS-conform
- halogen-free
- CFC-free
- silicone-free
- flame-retardant

Design

Conductor:	extremely fine stranded conductors of bare copper wires in an optimized hi-flex design
Center element:	type-dependent
Core insulation:	KS-PP/TPE
Core identification:	black with white numbers, protective conductor green/yellow
Core stranding:	conductor cores bundled in short pitches with minimal torsion (> 8 cores) conductor cores layered in short pitches with minimal torsion (≤ 8 cores)
Shielding:	coverage 85 %
Outer jacket:	KS-PUR
Jacket color:	black with ICC color identification based on the DESINA color code (orange type-dependent)
Inner jacket:	KS-PUR

Technical Data

Temperature range:	- 30 to + 90 °C
Minimum bend radius while moved*:	$KR_{min} \geq 7.5 \times \varnothing$
v_{max} unsupported:	20 m/s
v_{max} gliding:	5 m/s
a_{max}:	50 m/s ²
Insulation resistance:	≥ 30 MΩ x km
Rated voltage:	according to VDE 0.6/1kV according to UL 1kV

Approvals: UL, CSA, based on VDE

* smaller bend radii are suitable in a wide range of applications – please contact us



Type selection

LIFE-LINE Power 700 C – SHIELDED

core number x nominal-cross-section in mm ²	conductor cross section AWG (approximate values)	article number	max OD in mm	weight kg/m	Cu index kg/m
(2 x 1.5 ²)	(16 / 2c)	45760	9.3	0.122	0.061
(3 x 1.5 ²)	(16 / 3c)	45761	9.9	0.140	0.075
(4 x 1.5 ²)	(16 / 4c)	45762	10.4	0.160	0.089
(5 x 1.5 ²)	(16 / 5c)	45763	11.2	0.180	0.108
(7 x 1.5 ²)	(16 / 7c)	45765	12.8	0.245	0.148
(12 x 1.5 ²)	(16 / 12c)	45769	17.0	0.430	0.264
(18 x 1.5 ²)	(16 / 18c)	45772	22.2	0.670	0.410
(25 x 1.5 ²)	(16 / 25c)	45775	25.4	0.900	0.564
(36 x 1.5 ²)	(22 / 7c)	45777	30.5	1.260	0.698
(3 x 2.5 ²)	(14 / 3c)	45780	11.1	0.188	0.105
(4 x 2.5 ²)	(14 / 4c)	45781	11.7	0.220	0.142
(5 x 2.5 ²)	(14 / 5c)	45783	12.8	0.260	0.170
(7 x 2.5 ²)	(14 / 7c)	45785	15.2	0.340	0.224
(12 x 2.5 ²)	(14 / 12c)	45787	23.1	0.650	0.421
(18 x 2.5 ²)	(14 / 18c)	45789	26.2	0.970	0.584
(20 x 2.5 ²)	(14 / 20c)	45790	27.6	1.140	0.621
(25 x 2.5 ²)	(14 / 25c)	45791	29.4	1.290	0.765
(4 x 4 ²)	(12 / 4c)	45801	13.5	0.305	0.211
(4 x 6 ²)	(10 / 4c)	45802	16.3	0.435	0.298
(4 x 10 ²)	(8 / 4c)	45803	19.7	0.700	0.526
(4 x 16 ²)	(6 / 4c)	45804	24.7	1.050	0.781
(4 x 25 ²)	(4 / 4c)	45805	28.8	1.530	1.145
(4 x 35 ²)	(2 / 4c)	45806	32.7	2.000	1.667
(4 x 50 ²)	(1 / 4c)	45807	36.4	2.730	2.306
(4 x 70 ²)	(2 / 0 / 4c)	45808	45.8	4.050	3.045

LIFE-LINE Power 700 C PE/3 – SHIELDED

core number x nominal-cross-section in mm ²	conductor cross section AWG (approximate values)	article number	max OD in mm	weight kg/m	Cu index kg/m
(3 x 10 ² + 3 x 2.5 ² PE)	(8 / 3c + 14 / 3c)	45870	18.6	0.642	0.476
(3 x 16 ² + 3 x 2.5 ² PE)	(6 / 3c + 14 / 3c)	45871	21.8	0.937	0.694
(3 x 25 ² + 3 x 6 ² PE)	(4 / 3c + 10 / 3c)	45872	26.2	1.362	1.112
(3 x 35 ² + 3 x 6 ² PE)	(2 / 3c + 10 / 3c)	45873	31.0	1.990	1.398
(3 x 50 ² + 3 x 10 ² PE)	(2 / 3c + 8 / 3c)	45874	34.7	2.513	2.122
(3 x 70 ² + 3 x 16 ² PE)	(2 / 0 / 3c + 6 / 3c)	45875	41.3	3.700	2.912
(3 x 95 ² + 3 x 16 ² PE)	(3 / 0 / 3c + 6 / 3c)	45876	47.3	4.582	3.808





Core insulation
KS-PP/TPE
wire bundles
in very short pitches



Overall shield
continuous bending hi-flex,
tin-plated copper braiding,
for smallest bend radii
Coverage: approx. 85 %



Outer jacket
KS-PUR
pressure extruded
hi-flex design
UV-resistant
extremely abrasion-resistant

LIFE-LINE Power ONE 700 C

Shielded continuous bending hi-flex PUR single-core cables

Up to
7 million
motion cycles!

Up to
500 m
travel length!

LIFE-LINE
cables for
cable carriers

RoHS
conform

Developed for

- systems engineering and mechanical engineering
- crane and conveyor equipment
- power and supply cable
- extremely heavy loads

Properties

- oil-resistant
- UV-resistant
- RoHS-conform
- halogen-free
- CFC-free
- silicone-free
- flame-retardant

Design

Conductor:	extremely fine stranded conductors of bare copper wires in an optimized hi-flex design
Core insulation:	KS-PP/TPE
Core stranding:	Single-core
Shielding:	coverage 85 %
Outer jacket:	KS-PUR
Jacket color:	black (orange type-dependent) (black with KCC color identification based on the DESINA color code type-dependent)

Technical Data

Temperature range:	- 30 to + 90 °C
Minimum bend radius while moved*:	$KR_{min} \geq 7.5 \times \varnothing$
v_{max} unsupported:	20 m/s
v_{max} gliding:	5 m/s
a_{max}:	50 m/s ²
Insulation resistance:	≥ 30 MΩ x km
Rated voltage:	according to VDE 0,6/1kV according to UL 1kV
Approvals:	UL, CSA, based on VDE

* smaller bend radii are suitable in a wide range of applications – please contact us



Type selection

LIFE-LINE Power ONE 700 C – SHIELDED

core number x nominal-cross-section in mm ²	conductor cross section AWG (approximate values)	article number	max OD in mm	weight kg/m	Cu index kg/m
(1 x 2.5 ²)	(14 / 1c)	45815	6.5	0.070	0.041
(1 x 4 ²)	(12 / 1c)	45816	7.1	0.089	0.059
(1 x 6 ²)	(10 / 1c)	45817	8.1	0.110	0.079
(1 x 10 ²)	(8 / 1c)	45818	9.3	0.168	0.128
(1 x 16 ²)	(6 / 1c)	45819	10.6	0.220	0.190
(1 x 25 ²)	(4 / 1c)	45820	12.4	0.343	0.289
(1 x 35 ²)	(2 / 1c)	45821	13.5	0.425	0.393
(1 x 50 ²)	(1 / 1c)	45822	15.6	0.575	0.560
(1 x 70 ²)	(2 / 0 / 1c)	45823	18.5	0.900	0.873
(1 x 95 ²)	(3 / 0 / 1c)	45824	20.5	1.040	1.029
(1 x 120 ²)	(4 / 0 / 1c)	45825	24.0	1.428	1.272
(1 x 150 ²)	(250 MCM / 1c)	45826	26.0	1.750	1.578
(1 x 185 ²)	(350 MCM / 1c)	45827	27.8	2.130	1.956
(1 x 240 ²)	(400 MCM / 1c)	45828	32.2	2.780	2.506
(1 x 300 ²)	(500 MCM / 1c)	45829	36.2	3.637	3.192





Core insulation
KS-PP/TPE
stranded in pairs



Inner jacket
KS-PUR
valley-sealed,
pressure extruded,
hi-flex design



Overall shield
continuous bending hi-flex,
tin-plated copper braiding
for smallest bend radii
Coverage: approx. 85 %



Outer jacket
KS-PUR
pressure extruded
hi-flex design
UV-resistant
extremely abrasion-resistant

LIFE-LINE Data 700 C

Shielded continuous bending hi-flex PUR data cables

Up to **7 million** motion cycles!

Up to **200 m** travel length!



Developed for

- measurement and control equipment
- sensor equipment
- data and signal cables
- extremely heavy loads

Properties

- oil-resistant
- UV-stable
- RoHS-conform
- halogen-free**
- CFC-free
- silicone-free
- flame-retardant

Design

Conductor:	extremely fine stranded conductors of bare copper wires in an optimized hi-flex design
Core insulation:	KS-PP/TPE
Core identification:	according to DIN 47100
Core stranding:	cores bundled in pairs in short pitches with minimal torsion article number 45926: conductor cores layered in short pitches with minimal torsion
Shielding:	coverage 85 %
Outer jacket:	KS-PUR
Jacket color:	purple article number 45623: black article number 45926: grey
Inner jacket:	KS-PUR

Technical Data

Temperature range:	- 30 to + 90 °C
Minimum bend radius while moved*:	$KR_{min} \geq 7.5 \times \varnothing$
v_{max} unsupported:	20 m/s
v_{max} gliding:	5 m/s
a_{max}:	50 m/s ²
Insulation resistance:	$\geq 30 \text{ M}\Omega \times \text{km}$
Rated voltage:	according to VDE 300/300V according to UL 300V

Approvals: UL, CSA, based on VDE

* smaller bend radii are suitable in a wide range of applications – please contact us

** article number 45623 not halogen-free



Type selection

LIFE-LINE Data 700 C – SHIELDED

core number x nominal-cross-section in mm ²	conductor cross section AWG (approximate values)	article number	max OD in mm	weight kg/m	Cu index kg/m
(7 x 0.25 ²)	(24 / 7c)	45926	7.7	0.078	0.033
(2 x 2 x 0.25 ²)	(24 / 2c / 2p)	45623	6.5	0.046	0.023
(3 x 2 x 0.25 ²)	(24 / 2c / 3p)	45624	8.7	0.092	0.037
(4 x 2 x 0.25 ²)	(24 / 2c / 4p)	45625	9.0	0.105	0.045
(5 x 2 x 0.25 ²)	(24 / 2c / 5p)	45626	9.7	0.120	0.057
(6 x 2 x 0.25 ²)	(24 / 2c / 6p)	45627	10.0	0.130	0.061
(7 x 2 x 0.25 ²)	(24 / 2c / 7p)	45633	10.5	0.140	0.073
(8 x 2 x 0.25 ²)	(24 / 2c / 8p)	45628	11.8	0.180	0.086
(10 x 2 x 0.25 ²)	(24 / 2c / 10p)	45629	12.0	0.190	0.095
(12 x 2 x 0.25 ²)	(24 / 2c / 12p)	45630	12.1	0.195	0.100
(1 x 2 x 0.5 ²)	(20 / 2c / 1p)	45634	7.5	0.068	0.024
(3 x 2 x 0.5 ²)	(20 / 2c / 3p)	45636	9.8	0.130	0.058
(4 x 2 x 0.5 ²)	(20 / 2c / 4p)	45637	10.4	0.155	0.078
(5 x 2 x 0.5 ²)	(20 / 2c / 5p)	45638	11.4	0.180	0.091
(6 x 2 x 0.5 ²)	(20 / 2c / 6p)	45639	12.2	0.226	0.106
(12 x 2 x 0.5 ²)	(20 / 2c / 12p)	45642	15.0	0.325	0.204
(14 x 2 x 0.5 ²)	(20 / 2c / 14p)	45643	15.9	0.372	0.218
(1 x 2 x 0.75 ²)	(18 / 2c / 2p)	45646	7.9	0.083	0.029
(2 x 2 x 0.75 ²)	(18 / 2c / 1p)	45647	10.3	0.158	0.068
(4 x 2 x 0.75 ²)	(18 / 2c / 4p)	45649	11.4	0.190	0.105
(5 x 2 x 0.75 ²)	(18 / 2c / 5p)	45650	12.3	0.220	0.124
(6 x 2 x 0.75 ²)	(18 / 2c / 6p)	45651	13.1	0.250	0.155
(8 x 2 x 0.75 ²)	(18 / 2c / 8p)	45652	15.9	0.345	0.215
(12 x 2 x 0.75 ²)	(18 / 2c / 8p)	45654	17.4	0.425	0.293





Core insulation
KS-PP/TPE
stranded in pairs



Element shield
continuous bending hi-flex, tin-plated braided copper shield with the option of foil shield – see type/design



Inner jacket
KS-PUR
valley-sealed, pressure extruded, hi-flex design



Overall shield
continuous bending hi-flex, tin-plated copper braiding for smallest bend radii
Coverage: approx. 85 %



Outer jacket
KS-PUR
pressure extruded hi-flex design
UV-resistant
extremely abrasion-resistant

LIFE-LINE Data 700 CD / Data/Power 700 CD

Double-shielded continuous bending hi-flex PUR data cables

Up to **7 million** motion cycles!

Up to **200 m** travel length!

LIFE-LINE
cables for cable carriers

RoHS
conform

Developed for

- measurement and control equipment
- sensor equipment
- data and signal cables
- extremely heavy loads

Properties

- oil-resistant
- UV-stable
- RoHS-conform
- halogen-free
- CFC-free
- silicone-free
- flame-retardant

Design

Conductor:	extremely fine stranded conductors of bare copper wires in an optimized hi-flex design
Center element:	type-optimized
Core insulation:	KS-PP/TPE
Core identification:	according to DIN 47100 article number 45669: black with white numbers
Core stranding:	cores bundled in pairs in short pitches with minimal torsion
Shielding:	coverage 85 %
Outer jacket:	KS-PUR
Jacket color:	purple article number 45669: black with KS color identification based on the DESINA color code
Inner jacket:	KS-PUR

Technical Data

Temperature range:	- 30 to + 90 °C
Minimum bend radius while moved*:	$KR_{min} \geq 7.5 \times \varnothing$
v_{max} unsupported:	20 m/s
v_{max} gliding:	5 m/s
a_{max}:	50 m/s ²
Insulation resistance:	≥ 30 MΩ x km
Rated voltage:	according to VDE 300/300V according to UL 300V article number 45669: according to VDE 0.6/1kV according to UL 1kV
Approvals:	UL, CSA, based on VDE

* smaller bend radii are suitable in a wide range of applications – please contact us



Type selection

LIFE-LINE Data 700 CD – DOUBLE-SHIELDED

core number x nominal-cross-section in mm ²	conductor cross section AWG (approximate values)	article number	max OD in mm	weight kg/m	Cu index kg/m
(3 x (2 x 0.25 ²))	((24 / 2c) / 3p)	45661	11.9	0.180	0.077
(4 x (2 x 0.5 ²))	((20 / 2c) / 4p)	45662	14.9	0.270	0.142



LIFE-LINE Data / Power 700 CD – DOUBLE-SHIELDED

core number x nominal-cross-section in mm ²	conductor cross section AWG (approximate values)	article number	max OD in mm	weight kg/m	Cu index kg/m
(6 x (2 x 1 ²))	((20 / 2c) / 6p)	45668	22.4	0.610	0.302
(6 x (2 x 1.5 ²))	((16 / 2c) / 6p)	45669	26.0	0.845	0.403





Core insulation
KS-PP/TPE
concentrically
stranded



Inner jacket
KS-PP/TPE
valley-sealed,
pressure extruded,
hi-flex design



Overall shield
continuous bending hi-flex,
tin-plated copper braiding
Coverage: approx. 90 %
and foil shield



Outer jacket
KS-PUR
pressure extruded
hi-flex design
UV-resistant
extremely abrasion-resistant

LIFE-LINE Profibus 700 C

Shielded continuous bending hi-flex Profibus PUR cables

Up to
7 million
motion cycles!

Up to
100 m
travel length!

LIFE-LINE
cables for
cable carriers

RoHS
conform

Developed for

- Profibus applications
- sensor equipment
- data and signal cables
- extremely heavy loads

Properties

- oil-resistant
- UV-stable
- RoHS-conform
- halogen-free
- CFC-free
- silicone-free
- flame-retardant

Design

Conductor:	extremely fine stranded conductors of bare copper wires in an optimized hi-flex design
Center element:	type-optimized
Core insulation:	KS-PP/TPE
Core identification:	colored, Profibus
Core stranding:	cores type-optimized stranded in short pitches with minimal torsion
Shielding:	coverage 85 %
Outer jacket:	KS-PUR
Jacket color:	purple (according to DESINA)
Inner jacket:	KS-PP/TPE

Technical Data

Temperature range:	- 20 to + 60 °C
Minimum bend radius while moved*:	$KR_{min} \geq 15 \times \varnothing$
v_{max} unsupported:	3.5 m/s
v_{max} gliding:	2 m/s
a_{max}:	10 m/s ²
Insulation resistance:	$\geq 10 \text{ M}\Omega \times \text{km}$
Rated voltage:	according to VDE 300/300V
Approvals:	UL, based on VDE

* smaller bend radii are suitable in a wide range of applications – please contact us

Type selection

LIFE-LINE Profibus 700 C – SHIELDED

core number x nominal-cross-section in mm ²	conductor cross section AWG (approximate values)	article number	max OD in mm	weight kg/m	Cu index kg/m
(1 x 2 x 0.5 ²)	(20 / 2c / 1p)	45690	9.5	0.086	0.039



LIFE-LINE CAN-BUS 700 C

Shielded continuous bending hi-flex and robust PUR bus cables

kabelschlepp.de

Questions about cable carrier cables? Fon: +49 2762 4003-0

Picture obtainable



Core insulation
KS-PP/TPE
star quad
stranded



Inner jacket
KS-PP/TPE
valley-sealed,
pressure extruded,
hi-flex design



Overall shield
continuous bending hi-flex,
tin-plated copper braiding
for smallest bend radii
Coverage: approx. 85 %



Outer jacket
KS-PUR
pressure extruded
hi-flex design
UV-resistant
extremely abrasion-resistant



Jacket color
co-extruded
ICC color identification
based on
DESINA color code

Up to
7 million
motion cycles!

Up to
200 m
travel length!

LIFE-LINE
cables for
cable carriers

ICC
KABELSCHLEPP
Integrated Colour Code

RoHS
conform

Developed for

- CAN bus applications
- sensor equipment
- data and signal cables
- extremely heavy loads

Properties

- oil-resistant
- UV-stable
- RoHS-conform
- halogen-free
- CFC-free
- silicone-free
- flame-retardant

Design

Conductor:	extremely fine stranded conductors of bare copper wires in an optimized hi-flex design
Center element:	type-optimized
Core insulation:	KS-PP/TPE
Core identification:	colored, CAN-BUS
Core stranding:	cores type-optimized stranded in short pitches with minimal torsion
Shielding:	coverage 85 %
Outer jacket:	KS-PUR
Jacket color:	black with ICC color identification based on the DESINA color code
Inner jacket:	KS-PP/TPE

Technical Data

Temperature range:	-30 to +70 °C
Minimum bend radius while moved*:	$KR_{min} \geq 10 \times \varnothing$ (-30 to +70 °C) $KR_{min} \geq 7.5 \times \varnothing$ (-5 to +70 °C)
v_{max} unsupported:	3.5 m/s
v_{max} gliding:	2 m/s
a_{max}:	10 m/s ²
Insulation resistance:	$\geq 10 \text{ M}\Omega \times \text{km}$
Rated voltage:	according to VDE 300/300V according to UL 300V
Approvals:	UL, based on VDE

* smaller bend radii are suitable in a wide range of applications – please contact us

Type selection

LIFE-LINE CAN-BUS 700 C – SHIELDED

core number x nominal-cross-section in mm ²	conductor cross section AWG (approximate values)	article number	max OD in mm	weight kg/m	Cu index kg/m
(1 x 2 x 0.5 ²)	(20 / 2c / 1p)	45670	8.0	0.085	0.033
(2 x 2 x 0.5 ²)	(20 / 2c / 2p)	45672	8.4	0.095	0.044



USB 2.0
700 C

LIFE-LINE USB 2.0 700 C

Shielded continuous bending hi-flex USB PUR cables

kabelschlepp.de

Questions about cable carrier cables? Fon: +49 2762 4003-0

Picture obtainable.

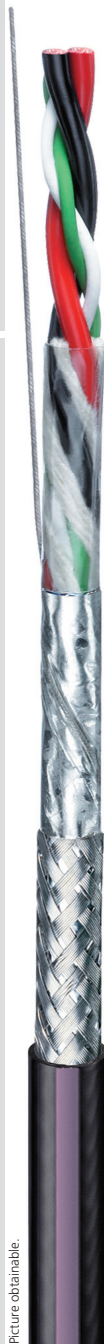

Core insulation
KS-PP/TPE
centrically
stranded



Overall shield
continuous bending hi-flex,
tin-plated copper braiding
Coverage: approx. 90 %
and foil shield



Outer jacket
KS-PUR
pressure extruded
hi-flex design
UV-resistant
extremely abrasion-resistant



Jacket color
co-extruded
ICC color identification
based on
DESINA color code

Up to
7 million
motion cycles!

Up to
5 m
travel length!

LIFE-LINE
cables for
cable carriers

ICC
KABELSCHLEPP
Integrated Colour Code

RoHS
conform

Developed for

- USB applications
- data and image transmission
- transmission lengths up to 5 m
- extremely heavy loads

Properties

- oil-resistant
- UV-resistant
- RoHS-conform
- halogen-free
- CFC-free
- silicone-free
- flame-retardant

Design

Conductor:	extremely fine stranded conductors of bare copper wires in an optimized hi-flex design
Center element:	type-optimized
Core insulation:	KS-PP/TPE
Core identification:	colored, red, black/white, white, green
Core stranding:	cores type-optimized stranded in short pitches with minimal torsion
Shielding:	coverage 85 %
Outer jacket:	KS-PUR
Jacket color:	black with ICC color identification based on the DESINA color code

Technical Data

Temperature range:	- 10 to + 70 °C
Minimum bend radius while moved*:	KR _{min} ≥ 10
v_{max} unsupported:	3.5 m/s
v_{max} gliding:	2 m/s
a_{max}:	10 m/s ²
Insulation resistance:	≥ 10 MΩ x km
Rated voltage:	according to VDE 30V according to UL 30V
Approvals:	UL, based on VDE

* smaller bend radii are suitable in a wide range of applications – please contact us

Type selection

LIFE-LINE USB 2.0 700 C

core number x nominal-cross-section in mm ²	conductor cross section AWG (approximate values)	article number	max OD in mm	weight kg/m	Cu index kg/m
(1 x 2 x 28 AWG + 2 x 20 AWG)	28 / 2c + 20 / 2c	45688	5.2	0.047	0.027





Core insulation
KS-PP/TPE
concentrically
stranded



Inner jacket
KS-PP/TPE
valley-sealed,
pressure extruded,
hi-flex design



Overall shield
continuous bending hi-flex,
tin-plated copper braiding
for smallest bend radii
Coverage: approx. 85 %



Outer jacket
KS-PUR
pressure extruded
hi-flex design
UV-resistant
extremely abrasion-resistant

LIFE-LINE Interbus 700 C

Shielded continuous bending hi-flex Interbus PUR cables

Up to
7 million
motion cycles!

Up to
200 m
travel length!

LIFE-LINE
cables for
cable carriers

RoHS
conform

Developed for

- Interbus applications
- sensor equipment
- data and signal cables
- extremely heavy loads

Properties

- oil-resistant
- UV-stable
- RoHS-conform
- halogen-free
- CFC-free
- silicone-free
- flame-retardant

Design

Conductor:	extremely fine stranded conductors of bare copper wires in an optimized hi-flex design
Core insulation:	KS-PP/TPE
Core identification:	colored, Interbus
Core stranding:	cores type-optimized stranded in short pitches with minimal torsion
Shielding:	coverage 85 %
Outer jacket:	KS-PUR
Jacket color:	purple (according to DESINA)

Technical Data

Temperature range:	- 30 to + 70 °C
Minimum bend radius while moved*:	$KR_{min} \geq 10 \times \varnothing$
v_{max} unsupported:	3.5 m/s
v_{max} gliding:	2 m/s
a_{max}:	10 m/s ²
Insulation resistance:	≥ 10 MΩ x km
Rated voltage:	according to VDE, Ø 0,25 mm ² 30V Ø 1 mm ² 300/300V according to UL 300V

Approvals: UL,
based on VDE

* smaller bend radii are suitable in a wide range of applications – please contact us



Type selection

LIFE-LINE Interbus 700 C – SHIELDED

core number x nominal-cross-section in mm ²	conductor cross section AWG (approximate values)	article number	max OD in mm	weight kg/m	Cu index kg/m
(3 x 2 x 0.25 ²)	(24 / 2c / 3p)	45676	8.3	0.085	0.047
(3 x 1 ² + 3 x 2 x 0.25 ²)	(17 / 2c + 24 / 2c / 3p)	45678	10.6	0.155	0.088



LIFE-LINE CAT5 700 C

Shielded continuous bending hi-flex PUR cable

kabelschlepp.de

Questions about cable carrier cables? Fon: +49 2762 4003-0

Picture obtainable.



Core insulation
KS-PP/TPE
concentrically
stranded



Overall shield
continuous bending hi-flex,
tin-plated copper braiding
Coverage: approx. 90 %
and foil shield



Outer jacket
KS-PUR
pressure extruded
hi-flex design
UV-resistant
extremely abrasion-resistant



Jacket color
co-extruded
ICC color identification
based on
DESINA color code

Up to
7 million
motion cycles!

Up to
60 m
travel length!

LIFE-LINE
cables for
cable carriers

ICC
KABELSCHLEPP
Integrated Colour Code

RoHS
conform

Developed for

- computer cables
- sensor equipment
- data and signal cables
- extremely heavy loads

Properties

- oil-resistant
- UV-resistant
- RoHS-conform
- halogen-free
- CFC-free
- silicone-free
- flame-retardant

Design

Conductor:	extremely fine stranded conductors of bare copper wires in an optimized hi-flex design
Core insulation:	KS-PP/TPE
Core identification:	colored, white/blue, blue, white/orange, orange, white/green, green, white/brown, brown
Core stranding:	cores type-optimized stranded in short pitches with minimal torsion
Shielding:	coverage 85 %
Outer jacket:	KS-PUR
Jacket color:	black with ICC color identification based on the DESINA color code

Technical Data

Temperature range:	- 20 to + 60 °C
Minimum bend radius while moved*:	$KR_{min} \geq 7.5 \times \varnothing$
v_{max} unsupported:	3.5 m/s
v_{max} gliding:	2 m/s
a_{max}:	10 m/s ²
Insulation resistance:	≥ 10 MΩ x km
Rated voltage:	according to VDE 30V according to UL 30V
Approvals:	UL, based on VDE

* smaller bend radii are suitable in a wide range of applications – please contact us

Type selection

LIFE-LINE CAT5 700 C – SHIELDED

core number x nominal-cross-section in mm ²	conductor cross section AWG (approximate values)	article number	max OD in mm	weight kg/m	Cu index kg/m
(4 x 2 x 0.15 ²)	(26 / 2c / 4p)	45693	6.8	0.055	0.030





Core insulation
KS-PP/TPE



Element shield
continuous bending hi-flex, tin-plated braided copper shield with the option of foil shield – see type/design



Overall shield
continuous bending hi-flex, tin-plated copper braiding
Coverage: approx. 90 %
and metallic non-woven shield



Outer jacket
KS-PUR
pressure extruded
hi-flex design
UV-resistant
extremely abrasion-resistant

LIFE-LINE DeviceNet 700 C

Shielded continuous bending hi-flex DeviceNet PUR cable



Up to
7 million
motion cycles!



Up to
200 m
travel length!

LIFE-LINE
cables for
cable carriers

RoHS
conform

Developed for

- CAN bus applications
- sensor equipment
- data and signal cables
- extremely heavy loads

Properties

- oil-resistant
- UV-resistant
- RoHS-conform
- halogen-free
- CFC-free
- silicone-free
- flame-retardant

Design

Conductor:	extremely fine stranded conductors of bare copper wires in an optimized hi-flex design
Core insulation:	KS-PP/TPE
Core identification:	colored, DeviceNet
Core stranding:	cores type-optimized stranded in short pitches with minimal torsion
Shielding:	coverage 85 %
Outer jacket:	KS-PUR
Jacket color:	purple (according to DESINA)

Technical Data

Temperature range:	– 30 to + 70 °C
Minimum bend radius while moved*:	$KR_{min} \geq 10 \times \varnothing$ (– 30 to + 70 °C) $KR_{min} \geq 7.5 \times \varnothing$ (– 5 to + 70 °C)
v_{max} unsupported:	3.5 m/s
v_{max} gliding:	2 m/s
a_{max}:	10 m/s ²
Insulation resistance:	≥ 10 MΩ x km
Rated voltage:	according to VDE 30V according to UL 30V
Approvals:	UL, based on VDE

* smaller bend radii are suitable in a wide range of applications – please contact us

Type selection

LIFE-LINE DeviceNet 700 C – SHIELDED

core number x nominal-cross-section in mm ²	conductor cross section AWG (approximate values)	article number	max OD in mm	weight kg/m	Cu index kg/m
(2 x (1 ²) + (2 x 0.75 ²))	((17 / 2c) + (18 / 2c))	45674	11.7	0.190	0.115



kabelschlepp.de

Questions about cable carrier cables? Fon: +49 2762 4003-0



Coax cable
flexible,
continuous bending hi-flex



Core insulation
KS-PP/TPE
centrically
stranded



Element shield
continuous bending hi-flex
copper braiding
– see type/design



Overall shield
continuous bending hi-flex,
tin-plated copper braiding
for smallest bend radii
Coverage: approx. 90 %



Outer jacket
KS-PUR
pressure extruded
hi-flex design
UV-resistant
extremely abrasion-resistant

Up to
2 million
motion cycles!

Up to
50 m
travel length!

LIFE-LINE
cables for
cable carriers

RoHS
conform

Developed for

- image transmission
- sensor equipment
- data and signal cables
- extremely heavy loads

Properties

- oil-resistant
- UV-resistant
- RoHS-conform
- CFC-free
- silicone-free
- halogen-free**

Design

Conductor:	extremely fine stranded conductors of bare copper wires in an optimized hi-flex design
Core insulation:	KS-PVC
Core identification:	article number 45680: black article number 45694: black with white numbers
Core stranding:	optimized stranding with maximum flexural strength
Shielding:	article number 45694: coverage 90 %
Outer jacket:	KS-PUR
Jacket color:	black

Technical Data

Temperature range:	– 5 to + 50 °C
Minimum bend radius while moved*:	article number 45680: $KR_{min} \geq 7.5 \times \varnothing$ article number 45694: $KR_{min} \geq 14 \times \varnothing$
v_{max} unsupported:	3.5 m/s
v_{max} gliding:	2 m/s
a_{max}²:	10 m/s²
Rated voltage:	article number 45680: according to VDE 30V, according to UL 30V article number 45694: 250V
Approvals:	UL**, based on VDE

* smaller bend radii are suitable in a wide range of applications – please contact us

** not article number 45694, no UL



Type selection

LIFE-LINE Koax 700 C – 50 Ohm – SHIELDED

core number x nominal-cross-section in mm ²	conductor cross section AWG (approximate values)	article number	max OD in mm	weight kg/m	Cu index kg/m
(1 x HF50) 50 Ohm	1 x (1HF50)	45680	5.2	0.040	0.020



LIFE-LINE Koax 700 CD – 75 Ohm – SHIELDED

core number x nominal-cross-section in mm ²	conductor cross section AWG (approximate values)	article number	max OD in mm	weight kg/m	Cu index kg/m
(3 x (1HF75)) 75 Ohm	(3 x (1HF75))	45694	11.3	0.143	0.063



LWL
700

LIFE-LINE LWL 700

Continuous bending hi-flex multi-mode glass fiber optic cable

Up to
7 million
motion cycles!

Up to
500 m
travel length!

LIFE-LINE
cables for
cable carriers

RoHS
conform

Developed for

- light signal transmission
- sensor equipment
- data and signal cables
- extremely heavy loads

Properties

- halogen-free
- Multimode 1300 nm
- RoHS-conform**
- absolutely EMC safety
- CFC-free
- silicone-free
- flame-retardant

Design

Conductor:	glass
Conductor insulation:	KS-PP/TPE
Conductor identification:	colored, color coded
Conductor stranding:	centrically around center element
Outer jacket:	KS-PUR
Jacket color:	black

Technical Data

Temperature range:	- 30 to + 90 °C
Minimum bend radius while moved*:	$KR_{min} \geq 7.5 \times \varnothing$
v_{max} unsupported:	3.5 m/s
v_{max} gliding:	2 m/s
a_{max}:	10 m/s ²
Approvals:	IEC 60794 IEC 61300

- * smaller bend radii are suitable in a wide range of applications – please contact us
** not article number 45696

kabelschlepp.de

Questions about cable carrier cables? Fon: +49 2762 4003-0



Fiber-optic cable glass
flexible, continuous bending hi-flex, aramid fiber protection



Core insulation KS-PP/TPE
centrically stranded



Inner jacket KS-PUR
valley-sealed, pressure extruded, hi-flex design



Outer jacket KS-PUR
pressure extruded hi-flex design UV-resistant extremely abrasion-resistant



Type selection

LIFE-LINE LWL 700

number of conductors x nominal-cross-section in µm	conductor cross section AWG (approximate values)	article number	max OD in mm	weight kg/m
6G50/125	6G 50/125	45696	8.7	0.340
6G62.5/125	6G 62.5/125	45697	13.4	0.140
12G50/125	12G 50/125	45698	13.4	0.140
12G62.5/125	12G 62.5/125	45699	13.4	0.140





Core insulation
KS-PP/TPE
hybrid stranded



Element shield
continuous bending hi-flex,
in-plated braided copper shield
with the option of foil shield
– see type/design



Overall shield
continuous bending hi-flex,
tin-plated copper braiding
for smallest bend radii
Coverage: approx. 80 %



Outer jacket
KS-PUR
pressure extruded
hi-flex design
UV-resistant
extremely abrasion-resistant

LIFE-LINE System S 800 C

Shielded continuous bending hi-flex PUR signal cables

Up to
5 million
motion cycles!

Up to
40 m
travel length!

LIFE-LINE
cables for
cable carriers

RoHS
conform

Developed for

- KS alternative to SIEMENS standard
- long transmission distances
- servo drives
- extremely heavy loads

Properties

- oil-resistant
- UV-resistant
- RoHS-conform
- halogen-free
- CFC-free
- silicone-free
- flame-retardant

Design

Conductor:	extra-fine wire conductor made from tin-plated copper wires, design-optimized for maximum flexural strength
Center element:	type-optimized
Core insulation:	KS-PP/TPE
Core identification:	according to SIEMENS specifications
Core stranding:	cores type-optimized stranded in short pitches with minimal torsion
Shielding:	coverage 80 %
Outer jacket:	KS-PUR
Jacket color:	green (according to DESINA)

Technical Data

Temperature range:	– 30 to + 90 °C
Minimum bend radius while moved*:	$KR_{min} \geq 7.5 \times \varnothing$
v_{max} unsupported:	6 m/s
v_{max} gliding:	3 m/s
a_{max}:	8 m/s ²
Insulation resistance:	≥ 10 MΩ x km
Rated voltage:	according to VDE 42V according to UL 30V
Approvals:	UL, CSA, based on VDE

* smaller bend radii are suitable in a wide range of applications – please contact us

Type selection

LIFE-LINE System S 800 C – SHIELDED

KS alternative to SIEMENS standard	type KS / construction	conductor cross section AWG (approximate values)	article number	max OD in mm	weight kg/m	Cu index kg/m
6FX8008 1BD11	$(8 \times 2 \times 0.18^2)$	$(25 / 2c / 8p)$	46100	8.7	0.100	0.053
6FX8008 1BD21	$(4 \times 2 \times 0.34^2 + 4 \times 0.5^2)$	$(22 / 2c / 4p + 20 / 4c)$	46105	9.3	0.115	0.081
6FX8008 1BD31	$(3 \times (2 \times 0.14^2) + 2 \times (0.5^2))$	$(35 / 2c / 3p + 24 / 2c)$	46110	10.0	0.125	0.081
6FX8008 1BD41	$(3 (2 \times 0.14^2) + 4 \times 0.14^2 + 2 \times 0.5^2)$	$((35 / 2c) / 3p) + 35 / 4c + 24 / 2c)$	46115	9.5	0.105	0.074
6FX8008 1BD51	$(3 \times (2 \times 0.14^2) + 2 \times 0.5^2 + 4 \times 0.14^2 + 4 \times 0.22^2)$	$((35 / 2c) / 3p) + 35 / 4c + 33 / 2c / 4p)$	46120	10.4	0.135	0.088
6FX8008 1BD61	$(4 \times 2 \times 0.18^2)$	$(33 / 2c / 4p)$	46125	6.9	0.061	0.028
6FX8008 1BD71	$(2 \times 2 \times 0.18^2)$	$(33 / 2c / 2p)$	46130	5.3	0.035	0.020
6FX8008 1BD81	(12×0.22^2)	$(31 / 12 c)$	46135	8.5	0.098	0.051





Core insulation
KS-PP/TPE
hybrid stranded



Element shield
continuous bending hi-flex,
in-plated braided copper shield
with the option of foil shield
– see type/design



Overall shield
continuous bending hi-flex,
tin-plated copper braiding
for smallest bend radii
Coverage: approx. 80 %



Outer jacket
KS-PUR
pressure extruded
hi-flex design
UV-resistant
extremely abrasion-resistant

LIFE-LINE System M 800 C

Shielded continuous bending hi-flex PUR motor drive cables



Up to
5 million
motion cycles!



Up to
40 m
travel length!

LIFE-LINE
cables for
cable carriers

RoHS
conform ✓

Developed for

- KS alternative to SIEMENS standard
- long transmission distances
- servo drives
- extremely heavy loads

Properties

- oil-resistant
- UV-resistant
- RoHS-conform
- halogen-free
- CFC-free
- silicone-free
- flame-retardant

Design

Conductor:	extremely fine stranded conductors of bare copper wires in an optimized hi-flex design
Center element:	type-optimized
Core insulation:	KS-PP/TPE
Core identification:	according to SIEMENS specifications
Core stranding:	cores type-optimized stranded in short pitches with minimal torsion
Shielding:	coverage 80 %
Outer jacket:	KS-PUR
Jacket color:	orange (according to DESINA)

Technical Data

Temperature range:	– 30 to + 90 °C
Minimum bend radius while moved*:	$KR_{min} \geq 7.5 \times \varnothing$
v_{max} unsupported:	6 m/s
v_{max} gliding:	3 m/s
a_{max}:	8 m/s ²
Insulation resistance:	$\geq 10 \text{ M}\Omega \times \text{km}$
Rated voltage:	according to VDE 0.6/1kV (control pairs 300/300V) according to UL 1kV

Approvals:	UL, CSA, based on VDE
-------------------	-----------------------------

* smaller bend radii are suitable in a wide range of applications – please contact us

Type selection

LIFE-LINE System M 800 C – SHIELDED

KS alternative to SIEMENS standard	type KS / construction	conductor cross section AWG (approximate values)	article number	max OD in mm	weight kg/m	Cu index kg/m
6FX8008 1BA11	$(4 \times 1.5^2 + (2 \times 1.5^2))$	$(16 / 4c + (16 / 2c))$	46150	12.6	0.240	0.146
6FX8008 1BA21	$(4 \times 2.5^2 + (2 \times 1.5^2))$	$(14 / 4c + (16 / 2c))$	46155	14.0	0.315	0.206
6FX8008 1BA31	$(4 \times 4^2 + (2 \times 1.5^2))$	$(12 / 4c + (16 / 2c))$	46160	15.3	0.423	0.285
6FX8008 1BA41	$(4 \times 6^2 + (2 \times 1.5^2))$	$(10 / 4c + (16 / 2c))$	46165	17.5	0.518	0.364
6FX8008 1BA51	$(4 \times 10^2 + (2 \times 1.5^2))$	$(8 / 4c + (16 / 2c))$	46170	20.8	0.840	0.541
6FX8008 1BA61	$(4 \times 16^2 + (2 \times 1.5^2))$	$(6 / 4c + (16 / 2c))$	46175	24.7	1.074	0.782
6FX8008 1BB11	(4×1.5^2)	$(16 / 4c)$	46200	10.4	0.145	0.094
6FX8008 1BB21	(4×2.5^2)	$(14 / 4c)$	46205	12.1	0.195	0.139
6FX8008 1BB31	(4×4^2)	$(12 / 4c)$	46210	13.2	0.275	0.207
6FX8008 1BB41	(4×6^2)	$(10 / 4c)$	46215	16.0	0.414	0.329
6FX8008 1BB51	(4×10^2)	$(8 / 4c)$	46220	19.4	0.640	0.479
6FX8008 1BB61	(4×16^2)	$(6 / 4c)$	46225	23.6	0.915	0.733
6FX8008 1BA25	$(4 \times 25^2 + (2 \times 1.5^2))$	$(4 / 4c + (16 / 2c))$	46250	27.9	1.460	1.212
6FX8008 1BA35	$(4 \times 35^2 + (2 \times 1.5^2))$	$(2 / 4c + (16 / 2c))$	46255	32.0	1.890	1.550
6FX8008 1BA50	$(4 \times 50^2 + (2 \times 1.5^2))$	$(1 / 4c + (16 / 2c))$	46260	35.8	2.690	2.190



LIFE-LINE System S 900 C

Shielded continuous bending hi-flex PUR signal cables

kabelschlepp.de

Questions about cable carrier cables? Fon: +49 2762 4003-0

Picture obtainable.



Core insulation
KS-PP/TPE
hybrid stranded



Element shield
continuous bending hi-flex,
in-plated braided copper shield
with the option of foil shield
– see type/design



Overall shield
continuous bending hi-flex,
tin-plated copper braiding
for smallest bend radii
Coverage: approx. 85 %



Outer jacket
KS-PUR
pressure extruded
hi-flex design
UV-resistant
extremely abrasion-resistant

Up to
5 million
motion cycles!

Up to
40 m
travel length!

LIFE-LINE
cables for
cable carriers

RoHS
conform

Developed for

- KS alternative to Bosch-Rexroth/INDRAMAT standard
- long transmission distances
- servo drives
- extremely heavy loads

Properties

- oil-resistant
- UV-resistant
- RoHS-conform
- halogen-free
- CFC-free
- silicone-free
- flame-retardant

Design

Conductor:	extremely fine stranded conductors of bare or tin-plated copper wires (46505) copper wires in an optimized hi-flex design
Center element:	type-optimized
Core insulation:	KS-PP/TPE
Core identification:	according to INDRAMAT specifications article number 46505 for system Heidenhain article number 46090 for system Baumüller
Core stranding:	cores type-optimized stranded in short pitches with minimal torsion
Shielding:	coverage 85 %
Outer jacket:	KS-PUR
Jacket color:	orange (according to DESINA)

Technical Data

Temperature range:	– 30 to + 90 °C
Minimum bend radius while moved*:	$KR_{min} \geq 7.5 \times \varnothing$
v_{max} unsupported:	6 m/s
v_{max} gliding:	3 m/s
a_{max}:	8 m/s ²
Insulation resistance:	≥ 10 MΩ x km
Rated voltage:	according to VDE 300/300V according to UL 300V article number 46505 42V UL
Approvals:	UL, CSA, based on VDE

* smaller bend radii are suitable in a wide range of applications – please contact us

Type selection

LIFE-LINE System S 900 C – SHIELDED

KS alternative to SIEMENS standard	type KS / construction	conductor cross section AWG (approximate values)	article number	max OD in mm	weight kg/m	Cu index kg/m
INK 0448	$(4 \times 2 \times 0.25^2 + 2 \times 0.5^2)$	$(24 / 2c / 4p + 20 / 2c)$	46400	9.1	0.100	0.054
INK 0271	$(34 \times 0.25^2 + 2 \times 0.5^2)$	$(24 / 34c + 20 / 2c)$	46405	11.0	0.185	0.120
INK 0209	$(4 \times 2 \times 0.25^2 + 2 \times 1^2)$	$(24 / 2c / 4p + 17 / 2c)$	46410	9.1	0.120	0.062
INK 0280	$(3 \times 0.25^2 + 3 \times (2 \times 0.25^2) + 2 \times 1^2)$	$((24 / 2c) / 3p + 24 / 3c + 17 / 2c)$	46412	11.5	0.160	0.114
INK 0532	$(4 \times 2 \times 0.14^2 + 4 \times 1^2 + (4 \times 0.14^2))$	$(25 / 2c / 4p + 18 / 4c + (25 / 4c))$	46415	10.3	0.155	0.092



LIFE-LINE System – SHIELDED

KS alternative to Heidenhain standard	type KS / construction	conductor cross section AWG (approximate values)	article number	max OD in mm	weight kg/m	Cu index kg/m
–	$(4 \times 2 \times 0.14^2 + 4 \times 0.5^2)$	$(25 / 2c / 4p + 20 / 4c)$	46505	8.4	0.095	0.056



LIFE-LINE System – SHIELDED

KS alternative to Baumüller standard	type KS / construction	conductor cross section AWG (approximate values)	article number	max OD in mm	weight kg/m	Cu index kg/m
–	$(5 \times 2 \times 0.14^2 + 2 \times 0.5^2)$	$(35 / 2c / 5p + 24 / 2c)$	46090	9.0	0.105	0.058



LIFE-LINE System M 900 C

Shielded continuous bending hi-flex PUR motor drive cables

kabelschlepp.de

Questions about cable carrier cables? Fon: +49 2762 4003-0

Order
LIFE-LINE Safety Cables
TOTALTRAX Complete Systems

Picture obtainable.



Core insulation
KS-PP/TPE
hybrid stranded



Element shield
continuous bending hi-flex,
in-plated braided copper shield
with the option of foil shield
– see type/design



Overall shield
continuous bending hi-flex,
tin-plated copper braiding
for smallest bend radii
Coverage: approx. 85 %



Outer jacket
KS-PUR
pressure extruded
hi-flex design
UV-resistant
extremely abrasion-resistant

Up to
5 million
motion cycles!

Up to
40 m
travel length!



Developed for

- KS alternative to Bosch-Rexroth/INDRAMAT standard
- long transmission distances
- servo drives
- extremely heavy loads

Properties

- oil-resistant
- UV-resistant
- RoHS-conform
- halogen-free
- CFC-free
- silicone-free
- flame-retardant

Design

Conductor:	extremely fine stranded conductors of bare copper wires in an optimized hi-flex design
Center element:	type-optimized
Core insulation:	KS-PP/TPE
Core identification:	according to INDRAMAT specifications
Core stranding:	cores type-optimized stranded in short pitches with minimal torsion
Shielding:	coverage 85 %
Outer jacket:	KS-PUR
Jacket color:	orange (according to DESINA)

Technical Data

Temperature range:	– 30 to + 90 °C
Minimum bend radius while moved*:	$KR_{min} \geq 7.5 \times \varnothing$
v_{max} unsupported:	6 m/s
v_{max} gliding:	3 m/s
a_{max}:	8 m/s ²
Insulation resistance:	≥ 10 MΩ x km
Rated voltage:	according to VDE 300/500V according to UL 0.6kV

Approvals: UL, CSA, based on VDE

* smaller bend radii are suitable in a wide range of applications – please contact us

Type selection

LIFE-LINE System M 900 C – SHIELDED

KS alternative to INDRAMAT standard	type KS / construction	conductor cross section AWG (approximate values)	article number	max OD in mm	weight kg/m	Cu index kg/m
INK 0653	$(4 \times 1^2 + 2 \times (2 \times 0.75^2))$	$(17 / 4c + (18 / 2c) / 2p)$	46300	12.7	0.225	0.136
INK 0650	$(4 \times 1.5^2 + 2 \times (2 \times 0.75^2))$	$(16 / 4c + (18 / 2c) / 2p)$	46305	12.7	0.255	0.158
INK 0602	$(4 \times 2.5^2 + 2 \times (2 \times 0.75^2))$	$(14 / 4c + (18 / 2c) / 2p)$	46310	14.9	0.345	0.234
	$(4 \times 2.5^2 + 2 \times (2 \times 1^2))$	$(14 / 4c + (18 / 2c) / 2p)$	46315	15.8	0.370	0.255
	$(4 \times 4^2 + (2 \times 1^2) + (2 \times 1.5^2))$	$(12 / 4c + (17 / 2c) / 2p + 16 / 2c)$	46323	17.5	0.475	0.328
	$(4 \times 4^2 + 2 \times (2 \times 1.5^2))$	$(12 / 4c + (16 / 2c) / 2p)$	46325	16.4	0.505	0.300
INK 0604	$(4 \times 6^2 + (2 \times 1^2) + (2 \times 1.5^2))$	$(10 / 4c + (17 / 2c) / 2p + 16 / 2c)$	46330	18.6	0.570	0.398
	$(4 \times 6^2 + 2 \times (2 \times 1.5^2))$	$(10 / 4c + (16 / 2c) / 2p)$	46335	19.0	0.630	0.400
	$(4 \times 10^2 + (2 \times 1.5^2) + (2 \times 1^2))$	$(8 / 4c + (17 / 2c) / 2p + 16 / 2c)$	46345	23.3	0.875	0.626
INK 0606	$(4 \times 16^2 + 2 \times (2 \times 1.5^2))$	$(6 / 4c + (16 / 2c) / 2p)$	46350	26.5	1.170	0.922
INK 0607	$(4 \times 25^2 + 2 \times (2 \times 1.5^2))$	$(4 / 4c + (16 / 2c) / 2p)$	46355	30.8	1.590	1.280
INK 0667	$(4 \times 35^2 + 2 \times (2 \times 1.5^2))$	$(4 / 4c + (16 / 2c) / 2p)$	46360	32.8	2.080	1.709



LIFE-LINE

pre-assembled

You need connection-ready harnessed **bus cables**?
Or harnessed **signal- or power cables** for drives –
in accordance to SIEMENS specifications?

Simply order by quoting just the **order number and cable length**, and wait for your original LIFE-LINE quality goods to arrive.

Connection-ready harnessed cables

- easy to order with just order number and cable length
- in accordance to SIEMENS specifications
- Just-in-time delivery of three work days
- **no minimum order quantities**
- **individual cable lengths without surcharge**
- checked and monitored for reliable connection

Properties of the LIFE-LINE cables:



LIFE-LINE USB 700 C pre-assembled

Shielded continuous bending hi-flex USB PUR cable

Properties of the LIFE-LINE cables:

- UV-resistant
 - CFC-free
 - Minimum bend radius 10 x Ø
 - halogen-free
 - flame-retardant
- Approvals: UL, based on VDE, RoHS conform



Picture obtainable.

cable type	article number	diameter mm	minimum bend radius moved KR _{min}
USB 700 C – type A/B	610490	5.2	10 x Ø

Smaller bend radii are possible in many cases – contact us about options.

LIFE-LINE CAT5 700 C pre-assembled

Shielded continuous bending hi-flex CAT5 PUR cable

Properties of the LIFE-LINE cables:

- UV-stable
 - CFC-free
 - Minimum bend radius 7.5 x Ø
 - halogen-free
 - flame-retardant
- Approvals: UL, based on VDE, RoHS conform

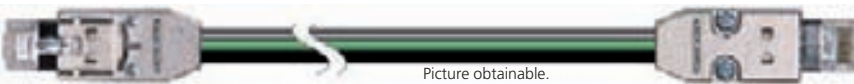

Picture obtainable.

cable type	article number	diameter mm	minimum bend radius moved KR _{min}
CAT5 8-stranded straight	610480	6.80	7.5 x Ø
CAT5 8-stranded cross-over	610485	6.80	7.5 x Ø

Smaller bend radii are possible in many cases – contact us about options.

LIFE-LINE pre-assembled PUR signal cables

Cables with connections compatible with the SIEMENS standard

Properties of the LIFE-LINE cables:

- UV-resistant
 - CFC-free
 - Minimum bend radius 7.5 x Ø
 - halogen-free
 - flame-retardant
- Approvals: UL, CSA, based on VDE, RoHS conform



Signal basic cables

PUR design



Picture obtainable.

KS alternative to SIEMENS standard	article number	diameter mm	minimum bend radius moved KR _{min}
6FX8002 2AD00	610610	9.50	7.5 x Ø
6FX8002 2CA31	610620	10.10	7.5 x Ø
6FX8002 2CA51	610630	9.50	7.5 x Ø
6FX8002 2CA61	610640	9.50	7.5 x Ø
6FX8002 2CF02	610650	9.50	7.5 x Ø
6FX8002 2CH00	610660	9.50	7.5 x Ø
6FX8002 2EQ00	610670	10.10	7.5 x Ø
6FX8002 2EQ10	610680	10.10	7.5 x Ø

Smaller bend radii are possible in many cases – contact us about options.

Signal extension cables

PUR design



Picture obtainable.

KS alternative to SIEMENS standard	article number	diameter mm	minimum bend radius moved KR _{min}
6FX8002 2AD04	610310	9.50	7.5 x Ø
6FX8002 2CA34	610315	10.10	7.5 x Ø
6FX8002 2CA54	610320	9.50	7.5 x Ø
6FX8002 2CB54	610325	9.30	7.5 x Ø
6FX8002 2CF04	610330	9.50	7.5 x Ø
6FX8002 2EQ14	610335	10.10	7.5 x Ø

Smaller bend radii are possible in many cases – contact us about options.

LIFE-LINE pre-assembled PUR power cables

Cables with connections compatible with the SIEMENS standard

Properties of the LIFE-LINE cables:

- UV-resistant
 - CFC-free
 - Minimum bend radius 7.5 x Ø
 - halogen-free
 - flame-retardant
- Approvals: UL, CSA, based on VDE, RoHS conform



Power basic cables without brake wires

PUR design



KS alternative to SIEMENS standard	article number	diameter mm	minimum bend radius moved KR _{min}
6FX8002 5CA01	610540	10.40	7.5 x Ø
6FX8002 5CA11	610550	11.70	7.5 x Ø
6FX8002 5CA21	610560	10.40	7.5 x Ø
6FX8002 5CA31	610570	11.70	7.5 x Ø
6FX8002 5CA41	610580	13.50	7.5 x Ø
6FX8002 5CA51	610590	16.30	7.5 x Ø
6FX8002 5CA61	610600	19.70	7.5 x Ø

Smaller bend radii are possible in many cases – contact us about options.

Power extension cables without brake wires

PUR design



KS alternative to SIEMENS standard	article number	diameter mm	minimum bend radius moved KR _{min}
6FX8002 5CA05	610340	10.40	7.5 x Ø
6FX8002 5CA15	610345	11.70	7.5 x Ø
6FX8002 5CA28	610350	10.40	7.5 x Ø
6FX8002 5CA38	610355	11.70	7.5 x Ø
6FX8002 5CA48	610360	13.50	7.5 x Ø
6FX8002 5CA58	610365	16.30	7.5 x Ø
6FX8002 5CA68	610370	19.70	7.5 x Ø

Smaller bend radii are possible in many cases – contact us about options.

LIFE-LINE pre-assembled PUR power cables

Cables with connections compatible with the SIEMENS standard

Properties of the LIFE-LINE cables:

- UV-resistant
 - CFC-free
 - Minimum bend radius 7.5 x Ø
 - halogen-free
 - flame-retardant
- Approvals: UL, CSA, based on VDE, RoHS conform



Power basic cables with brake wires PUR design



KS alternative to SIEMENS standard	article number	diameter mm	minimum bend radius moved KR _{min}
6FX8002 5DA01	610500	12.60	7.5 x Ø
6FX8002 5DA11	610510	14.00	7.5 x Ø
6FX8002 5DA21	610520	12.60	7.5 x Ø
6FX8002 5DA31	610530	14.00	7.5 x Ø

Smaller bend radii are possible in many cases – contact us about options.

Power extension cables with brake wires PUR design



KS alternative to SIEMENS standard	article number	diameter mm	minimum bend radius moved KR _{min}
6FX8002 5DA05	610375	12.60	7.5 x Ø
6FX8002 5DA15	610380	14.00	7.5 x Ø
6FX8002 5DA28	610385	12.60	7.5 x Ø
6FX8002 5DA38	610390	14.00	7.5 x Ø

Smaller bend radii are possible in many cases – contact us about options.



Extension cables

In addition to connection-ready harnessed basic cables, **extension cables** are also available. These are available as **signal and power cables** for drives – according to SIEMENS specifications.

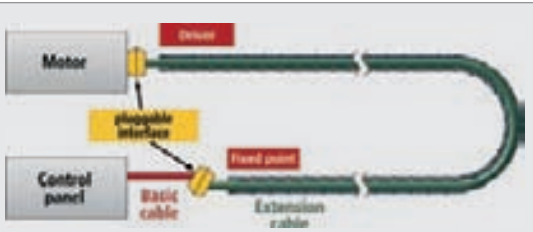
Simply order by quoting just the **order number and cable length**, and wait for your original LIFE-LINE quality goods to arrive.



Application parameters LIFE-LINE Safety Cables

Application parameters*	Control 200/200 C	Control 400/400 C	Power 400/400 C	Data / Control / Power 700/700 C	Series 800 C	Series 900 C
Acceleration a	up to 10 m/s ²	up to 20 m/s ²	up to 20 m/s ²	up to 50 m/s ²	subject to cable type	subject to cable type
Speed v, self-supporting	up to 3.5 m/s	up to 10 m/s	up to 5 m/s	up to 20 m/s	subject to cable type	subject to cable type
Speed v, gliding	up to 2 m/s	up to 5 m/s	up to 3 m/s	up to 5 m/s	subject to cable type	subject to cable type
Travel length recommended application areas	self-supporting, short to medium travel lengths – gliding with restrictions	self-supporting and gliding, medium to longer travel lengths	self-supporting and gliding, longer travel lengths	self-supporting and gliding, long travel lengths	subject to cable type	subject to cable type
DESINA	KABELSCHLEPP 	KABELSCHLEPP 	KABELSCHLEPP 	subject to cable type	subject to cable type	subject to cable type
Cold-resistant	•	•	•	•••	••	••
Minimum bend radius, unshielded	$KR_{min} \geq 9 \times \emptyset$	$KR_{min} \geq 7.5 \times \emptyset$	$KR_{min} \geq 7.5 \times \emptyset$	$KR_{min} \geq 7.5 \times \emptyset$	–	–
Minimum bend radius, shielded	$KR_{min} \geq 11 \times \emptyset$	$KR_{min} \geq 7.5 \times \emptyset$	$KR_{min} \geq 7.5 \times \emptyset$	$KR_{min} \geq 7.5 \times \emptyset^*$	subject to cable type	subject to cable type
UL-Approval 	+	+	+	+	+	+
Combined UL/CSA-Approval 	subject to cable type	subject to cable type	+	+	subject to cable type	subject to cable type
Operating temperature range	- 5 to + 80 °C	- 5 to + 80 °C	- 5 to + 80 °C	- 30 to + 90 °C*	subject to cable type	subject to cable type
UV-resistance	+	+	+	• jacket colored ••• jacket black	• jacket colored ••• jacket black	• jacket colored ••• jacket black
INDRAMAT-specification	–	–	–	–	–	+
SIEMENS-specification	–	–	–	–	+	–
CFC-free	+	+	+	+	+	+
flame-retardant	+	+	+	+	+	+
halogen-free	–	–	–	+	subject to cable type	subject to cable type
oil-resistant	+	+	+	+	+	+
silicone-free	+	+	+	+	+	+

+ Yes – No • suitable •• well suitable ••• very well suitable

* Recommended values for the design of KABELSCHLEPP cable carrier systems, deviations possible in case of data cables.

kabelschlepp.de

Questions about cable carrier cables? Fon: +49 2762 4003-0

Electrical load capacity

Cross section	PVC	PUR	PUR Single cores
0.75 mm ²	12 A		15 A
1 mm ²	15 A		19 A
1,5 mm ²	18 A	23 A	24 A
2,5 mm ²	26 A	32 A	32 A
4 mm ²	34 A	42 A	42 A
6 mm ²	44 A	54 A	54 A
10 mm ²	61 A	75 A	73 A
16 mm ²	82 A	100 A	98 A
25 mm ²	108 A	127 A	141 A
35 mm ²	135 A	158 A	176 A
50 mm ²	168 A	192 A	216 A
70 mm ²	207 A	246 A	279 A
95 mm ²	250 A	298 A	342 A
120 mm ²	292 A	346 A	400 A
150 mm ²	335 A	399 A	464 A
185 mm ²	382 A	456 A	533 A
240 mm ²	453 A	538 A	634 A
300 mm ²	523 A	621 A	736 A
400 mm ²			868 A
500 mm ²			998 A

DIN VDE 0298-4
page 33, chart 11, column 5

DIN VDE 0298-4
page 23, chart 6, column 5

DIN VDE 0298-4
page 33, chart 11, column 2

DIN VDE 0298-4
page 23, chart 6, column 7

These values are extracted from DIN VDE 0298-4. The laying procedure "Continuous flexible/moving in a cable carrier" is not standardized. Due to this fact these values are for orientation only. Please observe reduction factors for cumulation of cables and varying ambient temperatures while selecting cables. Please observe additional standards which will be security-relevant for the application.

All data in this publication are to be used as guidelines for planning purposes only. In particular, we do not guarantee that the products supplied suit the customer's application. It is the customer's responsibility to verify that our products fit the application specifications.

Conversion factors for different ambient temperatures

Ambient temperatures in °C	Permitted/recommended operating temperature at conductor					
	40 °C	60 °C	70 °C	80 °C	85 °C	90 °C
	Conversion factors, must be applied to the loading capacity information!					
10	1.73	1.29	1.22	1.18	1.17	1.15
15	1.58	1.22	1.17	1.14	1.13	1.12
20	1.41	1.15	1.12	1.10	1.09	1.08
25	1.22	1.08	1.06	1.05	1.04	1.04
30	1.00	1.00	1.00	1.00	1.00	1.00
35	0.71	0.91	0.94	0.95	0.95	0.96
40	-	0.82	0.87	0.89	0.90	0.91
45	-	0.71	0.79	0.84	0.85	0.87
50	-	0.58	0.71	0.77	-	0.82
55	-	0.41	0.61	0.71	-	0.76
60	-	-	0.50	0.63	-	0.71
65	-	-	0.35	0.55	-	0.65
70	-	-	-	0.45	-	0.58
75	-	-	-	0.32	-	0.50
80	-	-	-	-	-	0.41
85	-	-	-	-	-	0.29
90	-	-	-	-	-	-
95	-	-	-	-	-	-

Color codes, copper surcharge, AWG table

DIN 47100 color code

1 white	11 grey-pink	21 white-blue	31 green-blue	41 grey-black
2 brown	12 red-blue	22 brown-blue	32 yellow-blue	42 pink-black
3 green	13 white-green	23 white-red	33 green-red	43 blue-black
4 yellow	14 brown-green	24 brown-red	34 yellow-red	44 red-black
5 grey	15 white-yellow	25 white-black	35 green-black	
6 pink	16 yellow-brown	26 brown-black	36 yellow-black	
7 blue	17 white-grey	27 grey-green	37 grey-blue	
8 red	18 grey-brown	28 yellow-grey	38 pink-blue	
9 black	19 white-pink	29 pink-green	39 grey-red	
10 purple	20 pink-brown	30 yellow-pink	40 pink-red	

The first color describes the base color of the core insulation, the second color that of the printed ring.

Copper wire dimensions according to AWG

AWG-No.	Diameter mm	Cross section mm ²	AWG-No.	Diameter mm	Cross section mm ²
500	20.7	254	16	1.29	1.31
400	18.9	203	17	1.15	1.04
350	17.3	178	18	1.024	0.823
300	16	152	19	0.912	0.653
250	14.6	127	20	0.812	0.519
4/0	11.68	107.2	21	0.723	0.412
3/0	10.4	85	22	0.644	0.325
2/0	9.27	67.5	23	0.573	0.259
0	8.25	53.4	24	0.511	0.205
1	7.35	42.4	25	0.455	0.163
2	6.54	33.6	26	0.405	0.128
3	5.83	26.7	27	0.361	0.102
4	5.19	21.2	28	0.321	0.0804
5	4.62	16.8	29	0.286	0.0646
6	4.11	13.3	30	0.255	0.0503
7	3.67	10.6	31	0.227	0.04
8	3.26	8.366	32	0.202	0.032
9	2.91	6.63	33	0.18	0.0252
10	2.59	5.26	34	0.16	0.04
11	2.3	4.15	35	0.143	0.0161
12	2.05	3.3	36	0.127	0.0123
13	1.83	2.62	37	0.113	0.01
14	1.63	2.08	38	0.101	0.00795
15	1.45	1.65	39	0.0897	0.00632

Questions about cable carrier cables? Fon: +49 2762 4003-0

Calculation of the copper surcharge

The copper contained in cables is already calculated into the sales price at € 150.00 / 100 kg (copper basis).

The current price of copper, the German DEL quotation, rises and falls on a daily basis. The difference between the copper basis and the daily quotation is calculated and added to the cable price (copper surcharge).

The formula for calculating the copper surcharge (€/m):

$$\frac{\text{Copper number (kg/m)} \times ((\text{DEL quote (€/100 kg)} + 1\% \text{ procurement costs}) - \text{copper basis (€/100 kg)})}{100}$$

DEL quotation

The DEL quotation (Deutsches Elektrolytkupfer für Leitzwecke / German Electrolytic Copper for Conductor Purposes) is a market quotation for copper used in cables with a purity of over 95.5%.

Copper basis

Is the proportional value of copper already included in the cable price. This is € 150.00/100 kg copper for all LIFE-LINE cables.

Copper number

The copper number is the weight of the copper in a cable. This can vary greatly depending on the cross-section and the number of cores used, and is specified in kilograms per meter (kg/m).

Example:

Copper number: 0.152 kg/m

DEL notation: € 300.00 / 100 kg

Copper base: € 150.00 / 100 kg



Rebates and discounts do not apply to the copper surcharge. The copper surcharge is indicated separately in our invoices.

$$\frac{0.152 \text{ kg/m} \times ((€ 300.00 / 100 \text{ kg} + € 3.00 / 100 \text{ kg}) - € 150.00 / 100 \text{ kg})}{100}$$

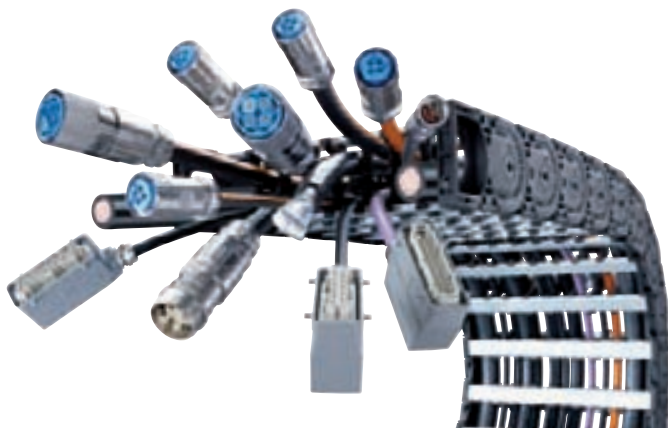
= € 0.23/m copper surcharge per meter of cable



Definitions

Definition	Description	Example
Design	number of cores x nominal cross-section in mm ²	3 x 1.5 ²
Design AWG	American Wire Gauge	18AWG/2c
Shielding	without	4 x 1.5 ²
	total	(4 x 1.5 ²)
	total and pair	(4 x (2 x 0.5 ²))
	total and pair and center element	((2 x 0.75 ²) + 2 x (1 ²))
DESINA	decentral and standardized installation technology on machine tools	
ICC	KABELSCHLEPP Integrated Colour Code System	 see page 347
Flame-retardant	according to UL or equal specification	
Halogen-free	according to VDE 0282-13 attachment C	700 Series
Oil-resistant	for special applications	see application parameters
UV-resistant	without any restriction	outer jacket: black / black + ICC
UV-stable	time restriction possible	outer jacket: colored
Stranding	core stranding in bundle technology	5 x 5 x 2.5 ² = 25 x 2.5 ²
	core stranding mixed, in hybrid technology	((4 x 50 ²) + 2 x (2 x 1.5 ²))
	core stranding in layer design	7 x 1.5 ²
	core stranding in pairs	(8 x 2 x 0.75 ²)

Abbreviation

Abbreviation	Description	Note
C	total shield with Cu-braid	optical coverage
D	double-shielded	CD identification
Ø max	maximum outer diameter	see type selection
EMV	electromagnetic compatibility	use shielded cables
LWL	fiber-optic cables – fiber/diameter	e.g. 6G62,5/125
KS-PUR	special KABELSCHLEPP compound	e.g. 11 Y
KS-TPE-E	Thermoplastic Polyester Elastomer	12 Y
KS-PP/TPE	special KABELSCHLEPP compound	e.g. 9 Y
KS-PVC	special KABELSCHLEPP PVC compound	Y
UL/CSA	USA/Canada approval	

Chemical resistance

Chemical product	Resistance				
	Control 200	Control/Power 400	Control/Power 700	Data 700 C/CD	Control/Power 700 C
Inorganic chemicals / aqueous solutions, neutral					
Water	✓	✓	✓	✓	✓
Common salt (10%)	✓	✓	✓	✓	✓
Sodium sulphate (10%)	✓	✓	✓	✓	✓
Aqueous solutions, alkaline					
Soda (10%)	✓	✓	✓	✓	✓
Aqueous solutions, acidic					
Aqueous solutions, oxidising	◆	◆	✓	✓	✓
Hydrogen peroxide (3%)	✓	✓	✓	✓	✓
Potassium permanganate (2%)	✓	✓	✓	✓	✓
Inorganic acids					
Concentrated hydrochloric acid	-	-	-	-	-
Hydrochloric acid (10 %)	✓	✓	✓	✓	✓
Concentrated sulphuric acid	-	-	✓	✓	✓
Sulphuric acid (10 %)	✓	✓	✓	✓	✓
Concentrated nitric acid	-	-	✓	✓	✓
Nitric acid (10 %)	○	○	✓	✓	✓
Inorganic alkalis					
Concentrated sodium hydroxide	-	-	✓	✓	✓
Sodium hydroxide (10 %)	✓	✓	✓	✓	✓
Concentrated caustic potash solution	-	-	✓	✓	✓
Caustic potash solution (10 %)	✓	✓	✓	✓	✓
Concentrated ammonia	○	○	✓	✓	✓
Ammonia (10 %)	✓	✓	✓	✓	✓
Organic chemicals / organic acids					
Concentrated acetic acid	-	-	✓	✓	✓
Acetic acid (10% in H ₂ O)	✓	✓	✓	✓	✓
Tartaric acid (10% in H ₂ O)	✓	✓	✓	✓	✓
Citric acid (10% in H ₂ O)	-	-	-	-	-
Ketones					
Acetone	-	-	-	-	-
Methyl ethyl ketone (MEK)	-	-	-	-	-
Alcohols					
Ethyl alcohol (white spirits)	-	-	○	○	○
Isopropyl alcohol	-	-	✓	✓	✓
Diethylene glycol	○	○	✓	✓	✓
Aromatics					
Toluene	-	-	-	-	-
Xylene	-	-	-	-	-
Fuels					
Petrol	-	-	✓	✓	✓
Diesel	○	○	✓	✓	✓
Kerosene	-	-	✓	✓	✓
Synthetic oils / lubricating oil					
ASTM oil #2	✓	✓	✓	✓	✓
Hydraulic fluid					
Based on mineral oil	-	-	✓	✓	✓
Based on glycol	-	-	✓	✓	✓
Based on synthetic ester	-	-	◆	◆	◆
Vegetable oils					
Rapeseed oil	○	○	✓	✓	✓
Olive oil	○	○	✓	✓	✓
Soybean oil	○	○	✓	✓	✓
Other					
Seawater	✓	✓	✓	✓	✓

✓ = resistant - = not resistant ○ = short-term resistance ◆ = no data

You don't know just how good a cable is until you see it in the carrier

Nothing proves the excellent performance of our products better than an uncompromising test



The following test set-ups were used as the basis for the indicated motion cycles:

LIFE-LINE Series 200

Test KS VL – 1 200



Travel length:	13.8 m	Speed:	2 m/s
Acceleration:	2.2 m/s ²	Radius:	7.5 to 8 x cable diameter

Result: over two million cycles

LIFE-LINE Series 400

Test KS VL – 2 400



Travel length:	17.4 m	Speed:	2.6 m/s
Acceleration:	2.2 m/s ²	Radius:	7.5 to 8 x cable diameter

Result: over four million cycles

LIFE-LINE Series 700

Test KS VL – 3 700



Travel length:	28.3 m	Speed:	3 m/s
Acceleration:	2.2 m/s ²	Radius:	7.5 to 8 x cable diameter

Result: over seven million cycles

With a LIFE-LINE cable from KABELSCHLEPP, you play it safe!

Installing cables into the cable carrier

Do not cut ring-coiled cables

When cutting cables prior to installation into the cable carrier, ring-coiled cables must be unspooled tangentially and not be pulled in loops off the top.

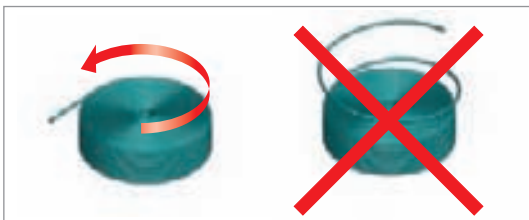

Uncoil cables from reels torsion-free

When cutting cables prior to installation into the cable carrier, drum-coiled cables must be unreeled, twist- and torsion-free.



Weight distribution inside the carrier cavity

When inserting the cables into the cable carrier, the cable weight is to be symmetrically distributed within the cavity width to assure maximum cycle life of the cable carrier and reduce the likelihood of cable carrier twist or tilt during operation.

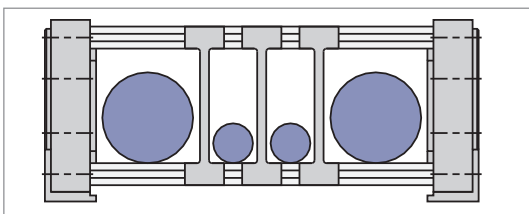

■ Right weight distribution

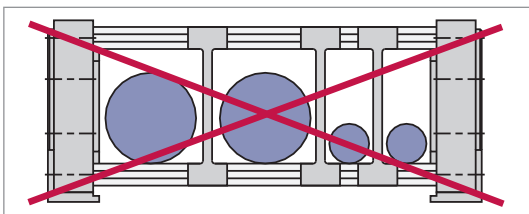

■ False weight distribution

Cable length

A change in the length of the cables after installation can be balanced out in the carrier loop. Thus, the cables must move freely inside the cable carrier at sufficient length and torsion-free.

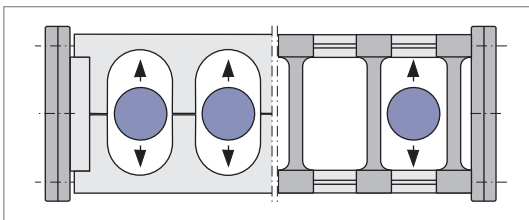

Installing cables into the carrier

The cables must be inserted into the carrier system in a way to allow them to move independently through the carrier's bend radius.

How to do it:

- Always allow sufficient clearance between the dividers and within the cable carrier cavity area.
- Insert cables tension-free.
- Never tie-wrap or fasten cables onto the carrier links or cross bars!

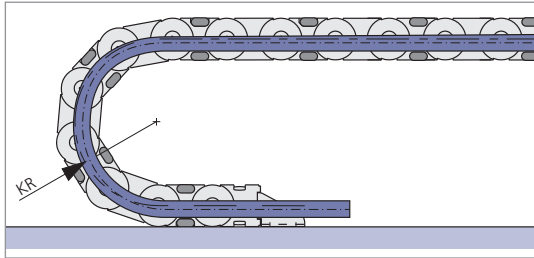

Strain relief at the driven end of the carrier

After positioning the driven end (moving end) in the **retracted position** the cables are strain-relieved at the moving end.

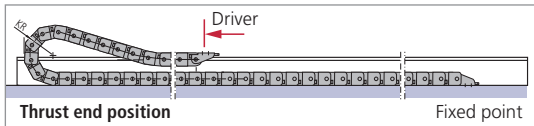

Correct cable length inside the carrier

After repositioning the driven end (moving end) in the carrier's **extended position** the cables are checked for tension-free length in the carrier loop and if necessary, pushed further into the carrier.

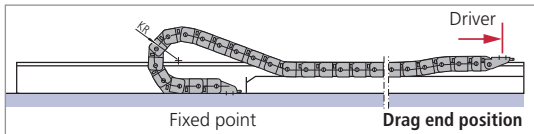

Strain relief at the fixed end of the carrier

At this tension-free "installation length", the cables are then strain-relieved at the carrier's fixed point.



LIFE-LINE Scout

Cable dimensioning for your cable carrier application

Inquiring party: Company: _____
 Contact person: _____
 Telephone: _____
 E-mail: _____
 ZIP code: _____ Town: _____
 Street address: _____

Cable application: Is the cable being used in a cable carrier?
 yes no

Number of cables: _____ (please attach a cable list if available)

Carrier application: Machine type: _____
 Carrier type: _____
 Free installation height H (mm): _____ Bend radius of carrier KR (mm): _____

Operational parameters: Travel length L_S (m): _____ Speed v (m/s): _____
 Acceleration a (m/s²): _____ approx. number of cycles (per year): _____

Cable design: No. of cores: _____ Core cross-section: _____

Shielding: unshielded shielded doubled shielded

Purchases & delivery: approx. requirements per year (m): _____ Lot size (m): _____
 coil reel
 Desired date for 1st delivery: _____ Length of 1st delivery: _____
 I would like a sample of a similar LIFE-LINE article no.: _____

Core identification: numbers + 1x gn/ye color acc. to DIN 47100

Voltage: Rated voltage U (V): _____

Capacitance: core/core c (nF/m): _____ core/shield c (nF/m): _____

Operating conditions: Operating temperature range: T_{min} (°C): _____ T_{max} (°C): _____
 Ambient conditions:
 indoor application outdoor application
 Chemical resistance: _____
 UV radiation: _____
 other radiation: _____

Approvals: UL UL/CSA other _____

Other: _____

Application examples



■ TOTALTRAX – the system solution for time-saving final assembly and short rework



■ Complete systems with a total weight of up to 10+ tons
 ■ Customer inspection, if desired, at the factory
 ■ Special packaging and transportation logistics for delivery to the construction site
 ■ Up to 50 % time saving during final assembly



■ MC-crane cable with cable package, SZL strain relief driven-end plate and sea-watertight AL-guide channel for worldwide use in port cranes



■ High-speed test stand
 ■ Durability tests exceeding 25 million cycles

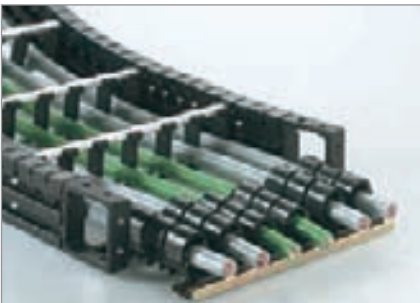

■ Optimized SZL-strain relief for long cable life – safe, compact, easy-to-assemble



■ 125 m travel length: carrier fully harnessed with LIFE-LINE Series 700

Definitions

Oil-resistant

The term "oil-resistant" means the chemical resistance of cables that are used in an environment where they are continuously exposed to oil or lubricants. Tests are carried out using approx. 55 oils and lubricants.

UV-resistant

The UV-resistance describes the resistance of the cable jacket to premature aging of the material due to sunlight. In addition, LIFE-LINE cables are also weather-resistant.

CFC-free

Chlorofluorocarbons

Due to the very detrimental effects of CFCs on the environment, and in particular on the ozone layer, we do not use them either in the manufacture of our products or in the products themselves.

Flame-retardant

Flame-retardant describes the fire behavior of cables tested according to IEC 60331. Flame retardant is a characteristic of the materials used in the insulation according to which it only catches fire after a delay when it is subjected to an open flame, and extinguishes itself when the flame is removed.

Silicone-free

The silicones used in cables are a very serious problem when applying paint, because if a surface contains silicone, paints and lacquers will not adhere to it properly. That is why all of our cables are generally silicone-free.

RoHS-compliant

Restriction of the use of certain hazardous substances in electrical and electronic equipment.

In particular, the use of lead, mercury and cadmium should be strictly limited.



Halogen-free

No materials such as chlorine, fluorine, iodine or bromide are used in our cables, because in the event of a fire corrosive gases would form hydrochloric acid, hydrofluoric acid, etc., thus greatly extending the scope of damage.

Profibus

This field bus was developed in Germany in 1989, and today is the most widespread bus of its type worldwide. It is used equally extensively in both production automation and process automation. We make a distinction between two types:

Profibus DP (Decentralized Periphery)

Sensors and actuators are controlled by a central controller. Data rates of up to 12 Mbit/s are possible.

Profibus PA (Process Automation)

Is used in process engineering and process technology. The data transfer rate is only 31.25 kbit/s.

Interbus

Is a field bus developed by the German company Phoenix Contact. The Interbus bus system is widely used in the automotive industry. The standard data transfer rate is 500 kBit/s.

Definitions

CAN-BUS

Is a bus system developed by Bosch. The CAN bus was developed for use in vehicles. Its data transfer capabilities are thus very large over short distances, but decrease greatly as the distance increases. The data transfer rate up to 40 m is 1 Mbit/s. Variants of the CAN bus:

CAN open – Primarily used in Europe.

DeviceNet – Primarily used in the USA. Developed by Allen-Bradley.

USB

Universal Serial Bus

A serial bus developed by Intel that connects a PC with external devices. USB 2.0 achieves a data rate of 480 Mbit/s, which gives it an advantage over the industrial bus systems, but because it transfers data only in packets, it is less suitable for time-critical applications.

LWL

Fiber-optic cables

Electric signals are converted by an optocoupler into light pulses, transferred via the fiber-optic cable and then converted back. The transfer rate is larger than for all comparable copper cables, and furthermore the cables are not subject to electromagnetic influences, and thus particularly suitable for industrial environments. The data transfer rate at 1300 nm/km is up to 10 Gbit/s. The fiber-optic cables can be made of plastic (POF) or glass.

Cable carrier suitability

Cable carrier suitability designates the characteristic of a cable to be moved continuously in a cable carrier. This characteristic is present if the cable can withstand more than one million motion cycles. All of the cables offered in our catalog are cable carrier suitable.



Servo cable

Servo cables designate cables that, in addition to the electric power required for the drive, can also transmit the signals generated by the servo controller. These measurements are made by means of an encoder such as a resolver, an incremental encoder or an absolute encoder.

Center element

The center element serves to fill the cavity that is present with an extruded jacket. This center element must be able to hold the stranded assembly securely in position. It is one of the essential elements of our LIFE-LINE cables.

Rated voltage

The rated voltage designates the working range of the cable as defined by standards. The permissible voltage may differ depending on the approval.

Insulation resistance

The insulating materials used oppose the flow of electric current with a very high resistance. This is inversely proportional to the cable length. The insulation resistance is a measure of the quality of the insulating material between two conductors or between a conductor and a shield.

Temperature range

The temperature range designates the range in which the cables can be moved in a cable carrier. It is dependent on the insulating materials employed in the cable. Use outside of the specified temperature spectrum will result in significant damage to the cable.

Definitions

ICC

Integrated Color Code

Part-extruded color code based on the DESINA color code. Cable types are easy to distinguish, thus greater safety and shorter assembly times.



TOTALTRAX

Pre-assembled cable carrier systems.

Ready-to-connect cable carrier complete systems with system guarantee.

Approvals

Our cables feature extensive approvals: here are a few examples of the possibilities for KABELSCHLEPP LIFE-LINE cables:

UL – Underwriters Laboratories

Required approval for use in the US market.



CSA – Canadian Standards Association

Required approval for use in the Canadian market.



CE – Conformité Européenne

The cable conforms with the EU directives for use and sales.



Technical plastics

Insulating materials

The insulating materials used in our LIFE-LINE cables can be subdivided into the following groups:

PVC – polyvinyl chloride

The material most often used in the cable industry. Plasticizers, stabilizers, masterbatches and other additives are added to form an individual mix, i.e. KS-PVC. Operating temperature: from – 5 °C to + 80 °C

PUR – polyurethane

Besides a significantly higher notch toughness, polyurethane is also more resistant to chemicals. Its very good flexibility at low temperature makes this material excellent for outdoor applications. Operating temperature: from – 30 °C to + 90 °C

PP – polypropylene

Because of its very high dielectric strength, polypropylene is a very good insulating material. In combination with PUR insulation it is thus possible to produce cables that are excellent for use in cable carriers. Operating temperature: from – 30 °C to + 90 °C

CAT cables

Unlike with normal data cables, with a Cat cable the transfer parameters are always specified, and therefore the damping and frequency of transfer are clearly defined.

Cat 5

Frequency of transfer: 100 MHz
Damping: 22 dB
NEXT (min. at 100 MHz): 32.3 dB

Cat 5e

Frequency of transfer: 100 MHz
Damping: 22 dB
NEXT (min. at 100 MHz): 35.3 dB

Cat 6

Frequency of transfer: 250 MHz
Damping: 19.8 dB
NEXT (min. at 100 MHz): 44.3 dB

Ethernet

Ethernet is a defined standard for data transfer in networks (LANs). At present the transfer rates are up to 100 Mbit/s.

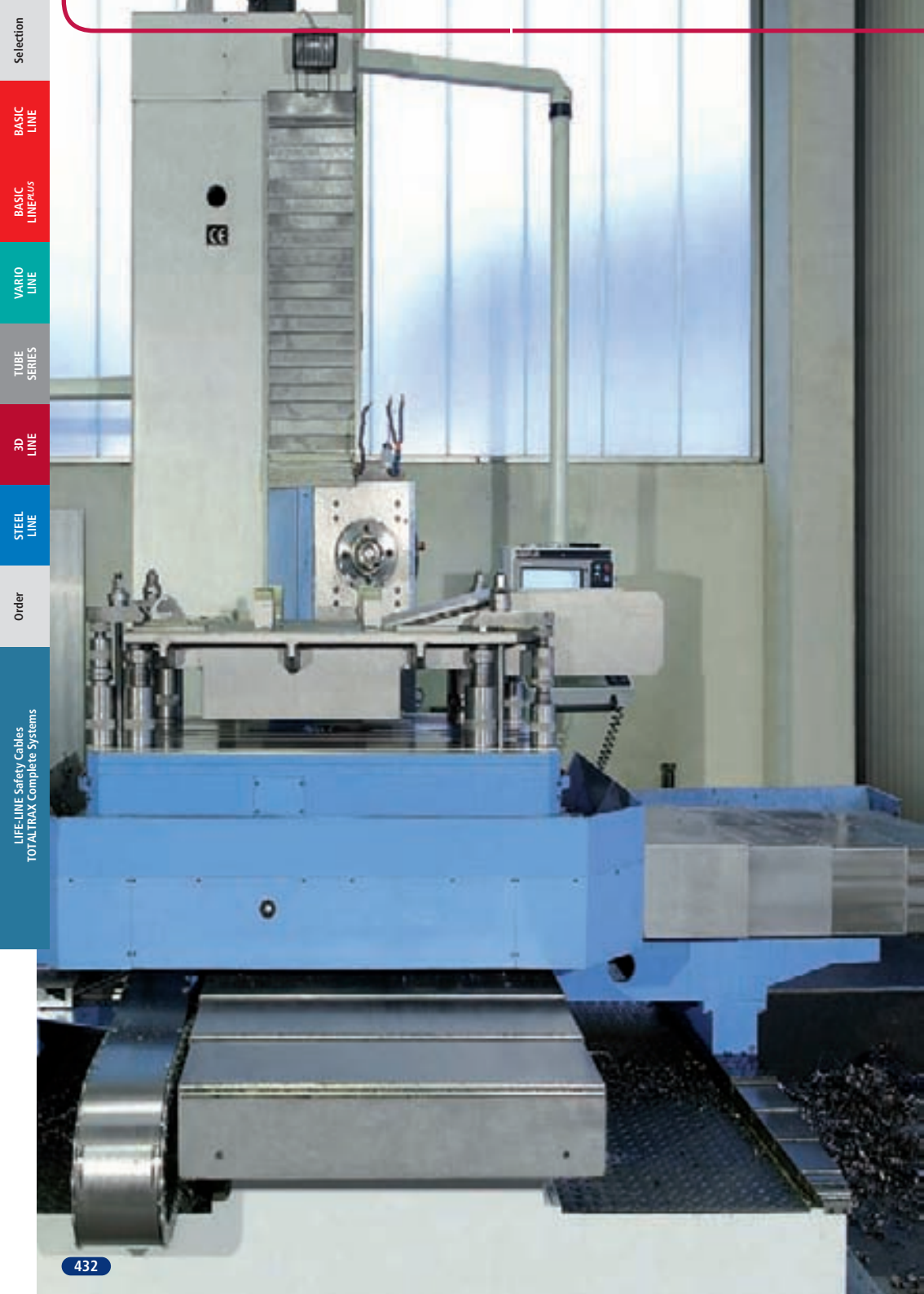

Selection

BASIC
LINE

BASIC
LINEPLUS

VARIO
LINE

TUBE
SERIES

3D
LINE

STEEL
LINE

Order

LIFE-LINE Safety Cables
TOTALTRAX Complete Systems

3

Guideway Protection and Conveyor Systems



GUIDEWAY PROTECTION SYSTEMS

CONVEYOR SYSTEMS

PROTECTIVE DEVICES

Safe. Clean. Reliable

Guideway Protection and Conveyor Systems

KABELSCHLEPP – that is motion. Motion as a principle of continuous development, a never-ending series of new inventions. Just like our product range. KABELSCHLEPP supplies reliable complete solutions covering all aspects of motion and transport for your machines.



From standard to customized

Where not only standard products, but also customer-specific solutions are the order of the day, being close to the customer is not just empty words, but a way of life.



Service is one of our greatest priorities

We are available for you 24 hours a day. Because our service department is oriented towards your requirements: If your production is down only because a conveyor system or a telescopic cover is out of order, then we can give you quick, reliable help.

It is often most advantageous to repair the equipment, since generally custom-manufactured items are involved. Our service technicians are familiar with many different manufacturers, and are thus able to get your production up and running very quickly.

- Installation, maintenance and repair right at your location
- Large repairs and general overhauls at our Service Center in Hünsborn, Germany
- Quick delivery of spare parts
- Training your personnel for maintenance and small repairs
- Specimen construction and manufacture of prototypes



■ KABELSCHLEPP Service-Center Hünsborn



■ Repair stands in Hünsborn

SERVICE-HOTLINE: + 49 2762/97420 · kabelschlepp-service.de

Efficient and flexible thanks to modern manufacturing organisation

Efficiency – that is the key word that guides our entire company. A challenge that is part of the 21st century, and a challenge that we are eager to meet.

Our production facility for protection and conveyor systems is one of the most modern in Europe.

Constant investments in the most modern manufacturing systems and the expansion of our production areas to approximately 3500 m² give you very visible benefits:

- Top quality
- Short delivery times
- An excellent price/performance ratio



■ KABELSCHLEPP System Engineering



■ KABELSCHLEPP System Engineering Manufacturing

Hinged belt conveyors 442

Scraper conveyors 450

Modular conveyors 454

Belt conveyors 456

Telescopic covers 460

Way wipers 474

Link apron covers 483

Bellows 487

Conical spring covers 498

Roll-up covers 492

Protective devices 494

KABELSCHLEPP is a provider of solutions, e.g.:

Part conveyor – scratch-free parts transfer at production machines

The part conveyor is a solution for automatic production on punching nibbling machines. Both smooth and angular parts can be transported. The overall concept and the integration into the machine were developed in cooperation with our customers.



Gentle transport all the way to the parts depot

The parts conveyor provides the option of gently transporting parts with high standards for surface quality out into the required parts depot. The brush rollers in the discharge area ensure that the materials being transported are transferred to the parts depot virtually horizontally.

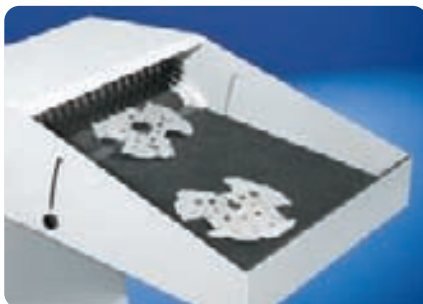

KABELSCHLEPP is a provider of solutions, e.g.:

Chip protection wall can be traversed horizontally and vertically – variable chip protection

Machining tools should be kept ready near the machining area. To prevent damage and fouling of the tools that are kept ready, they have to be given special protection. Our chip protection wall separates the machining cell from the tool magazine and protects the tools in the magazine that are not needed for the current machining operation.

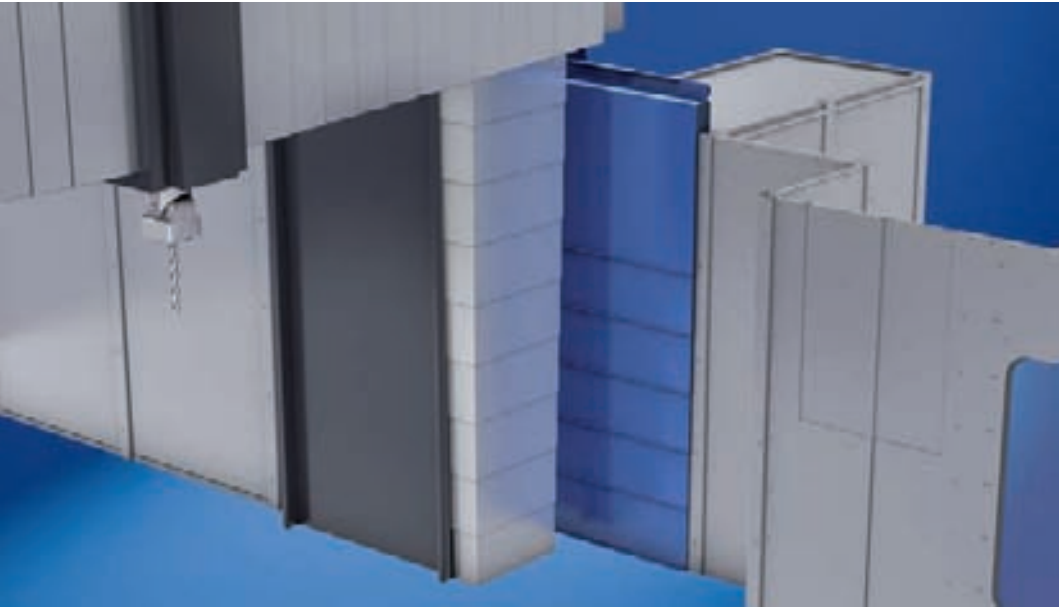

Variable protection of the tool magazine

The chip protection wall is fastened to a height-adjustable cross-beam, and moves with it in the vertical direction. An electric drive moves the wall in the horizontal direction for tool changing.

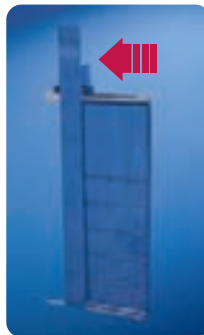

Subject to change.



Selection

BASIC
LINE

BASIC
LINEPLUS

VARIO
LINE

TUBE
SERIES

3D
LINE

STEEL
LINE

Order

LIFE-LINE Safety Cables
TOTALTRAX Complete Systems

Conveyor Systems

KABELSCHLEPP

Conveyor systems

Reliability and experience based on tradition



Hinged belt conveyors

page 442

Proven for a wide range of disposal tasks



Scraper conveyors

page 450

For disposal of small materials



Modular conveyors

page 454

Hinged belt conveyors with modular construction



Belt conveyors

page 456

The all-rounders – also for parts with sharp edges

Conveyor systems

Reliability and experience based on tradition

Our scraper belt, hinged belt and belt conveyors embody more than 30 years of experience. Systematic further development of our products and adaptation of their functions for use with the latest generation of machines guarantees you the utmost level of reliability.

Every production machine requires a disposal system

In the metalworking industry, tonnes of metal chips are created every day at cutting machine tools. We offer the right chip removal system and the suitable conveyor for your specific application.

- For disposal of chips at machine tools
- For transporting metal scrap and chips away from saws
- For disposal at stamping presses and laser cutting systems
- For disposal of edge scrap at trimming shears in coil cutting systems
- For transporting away casting waste in foundry lines



■ Standard hinged belt conveyor at a CNC boring machine

From standard to customized – we have a solution

- Everything from a single source – planning, design and manufacturing
- Standard conveyors available within a short time
- For an individual solution we will work together with you to design a suitable conveyor
- The optimal solution for whatever material is to be conveyed: hinged belt conveyor, scraper conveyor or belt conveyor
- Can be supplied with coolant processing if required
- Quality and long service life are our strong points
- Spare parts supplies are of course ensured for years to come
- Great price-performance ratio

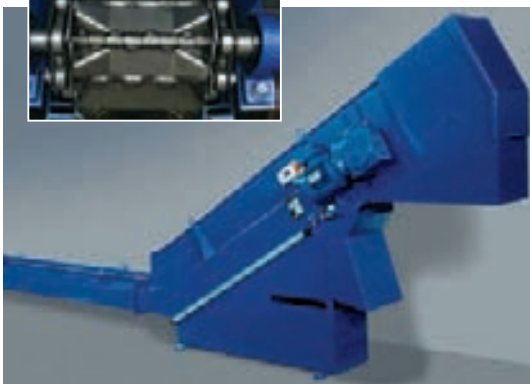

■ Hinged belt conveyor developed for the Trumf TUBEMATIC laser cutting machine. Special hinged belt plates prevent jamming of the material to be conveyed.

kabelschlepp.de

Fon: +49 2762 4003-0

Enquiry forms – page 503



kabelschlepp.de

Fon: +49 2762 4003-0

Enquiry forms – page 503

Designs and areas of application

Conveyors are an aspect of mechanical engineering, and are used especially on cutting machine tools. For **many applications** it is possible to use our **standard models**. The material to be conveyed, volume to be conveyed, and space limitations often already determine the type of conveyor.

In most cases, the variable dimensions such as the belt width, feed length, discharge height and incline are sufficient to take the requirements of the specific application in to account.



■ Hinged belt conveyors



■ Scraper conveyors



■ Belt conveyors

We also plan and manufacture special conveyors for very specific requirements, even complete chip disposal systems with machine cleaning, crushing, workshop cleaning and hopper storage.



■ Hinged belt conveyor for loading of a hopper system



■ Special model at a trimming shear with a belt width of 900 mm



■ Scraper conveyor for distribution of various chip materials



■ Scraper conveyor under a hopper system for aluminium chips

Hinged belt conveyors

Proven for a wide range of disposal tasks

Transportation of the material takes place on the upper trough of a revolving hinged belt. Drivers ensure transport of the material up the inclined section.

For wet machining the cooling lubrications are collected in the conveyor housing and can be fed back into the machine circuit via an optionally available coolant container or a pump station.

Our hinged belt conveyors can be used either as stand-alone conveyors at machine tools, or as linked conveyor systems. Depending on the design, the material to be conveyed is brought to the required height at a defined incline and then discharged.



This way we can solve your disposal tasks in over 80 % of all cases:

- Wet or dry chips
- Workpieces and waste
- Hot forgings
- Stampings and punching scrap
- And much more

■ Hinged belt conveyors

Structure

- Stable metal plate construction
- Standardized housing cross-section with variable width
- Robust worm gear motor with torque switching
- Customized discharge height
- Customized incline standards = 30°, 45° and 60°
- Floor mounting or as a push-in version into the machine base

Accessory examples

- Motor monitoring systems with current-monitoring relay
- Other overload safety devices (on request)
- Coolant container with pump station
- Direct electrical connection to your machine controller
- Other special solutions are available. Please do get in touch with us, we will be happy to advise you.



kabelschlepp.de

Order

Fon: +49 2762 4003-0

LIFE-LINE Safety Cables
TOTALTRAX Complete Systems

Conveyor Systems

Enquiry forms – page 504

Typical designs

Straight design

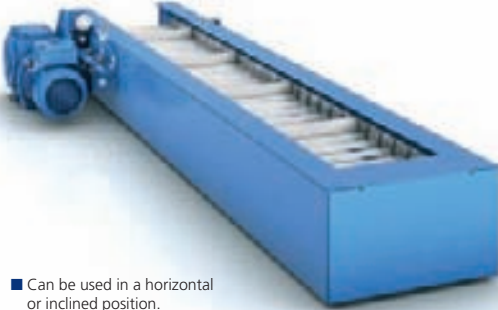

- Can be used in a horizontal or inclined position.
Max incline 45°

Straight/rising design



- Max. incline 45°

Straight/rising/straight design



- Max. incline 60°



Hinged belt conveyors

Proven for a wide range of disposal tasks

Types and main areas of application

SRF 040.00 – the elegant “small one”, and particularly compact

Pitch of the hinged belt $t = 40$ mm

With its small pitch (40 mm) and extremely compact design, this conveyor is suitable for even the smallest machine tools.



SRF 063.00 – the “classic”, and our best seller

Pitch of the hinged belt $t = 63$ mm

The conveyor type for most mechanical engineering applications.

SRF 100.00 – the “big one” and especially robust

Pitch of the hinged belt $t = 100$ mm

With a pitch of 100 mm, this conveyor is particularly useful when large quantities of chips are present.



SRF 150.00 – the “strongest” one we build

Pitch of the hinged belt $t = 150$ mm

Special solutions with 150 mm pitch for transporting away of large outputs or large parts.



Hinged belt designs

Various hinged belt designs are available for different operating conditions:

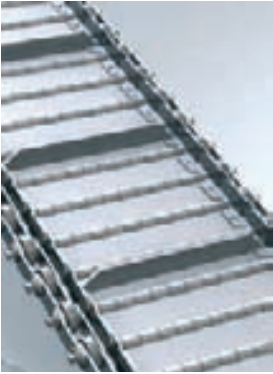

■ **Hinged belt (standard)**
for dry materials and chips with a low proportion of coolant



■ **Hinged belt with perforations**
for pre-separation of coolant for materials with a high proportion of coolant



■ **Hinged belt conveyor with corrugations**
for transporting "sticky" parts

Standard dimensions

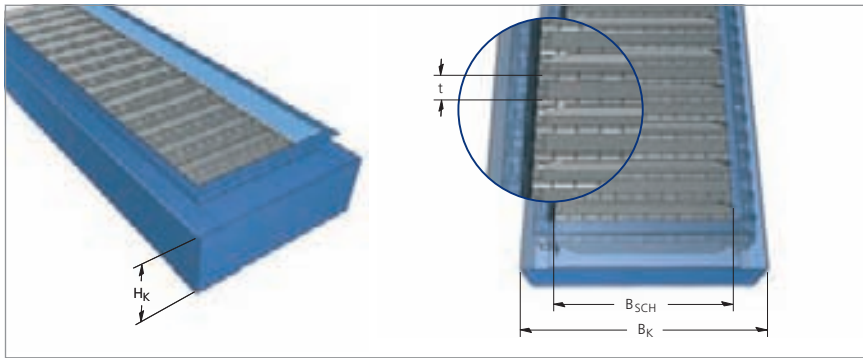

Type	Pitch t	Box height HK	Hinged belt width BSCH	Box width BK
SRF 040.00	40	140	150, 200, 250, 300, 450, 600	BSCH + 75 mm
SRF 063.00	63	216	150, 300, 450, 600, 750, 900	BSCH + 120 mm
SRF 100.00	100	360	150, 300, 450, 600, 750, 900	BSCH + 150 mm
SRF 150.00	150	540	300, 450, 600, 750, 900	BSCH + 190 mm

Special widths on request.

Hinged belt conveyors

Proven for a wide range of disposal tasks

Dimensions of conveyor housing

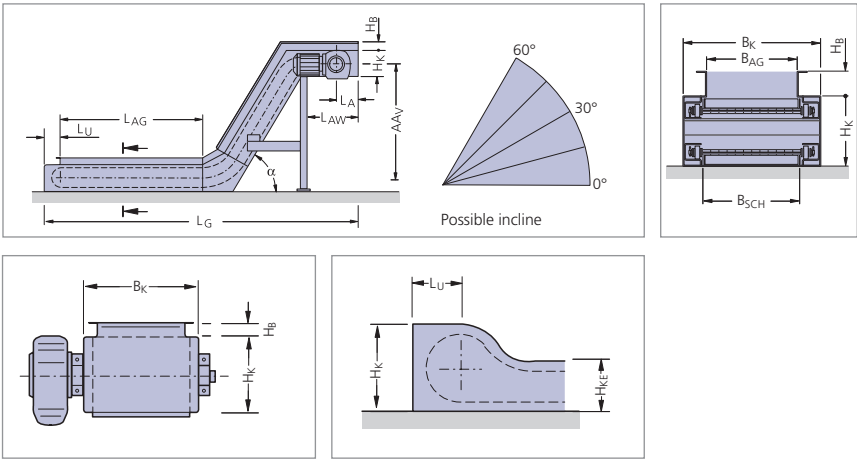

Variable dimensions:

- B_{Sch} = Hinged belt width
- B_K = Box width
- B_{AG} = Feed width
- H_B = Panel height
- AAV = Distance between axles, vertical
- L_{AG} = Feed length
- L_{AW} = Discharge length
- L_G = Total length of the conveyor
- α = Incline

Design-dependent dimensions:

- H_K = Box height
 - H_{KE} = Retracted box height
 - L_A = Length of the tail (discharge, incl. tensioning distance)
 - L_U = Length of the tail (feed)
- The tensioning station is located at the discharge.

Type	B _K	H _B	L _{AW}	H _K	H _{KE}	L _{AW} min	L _A	L _U
SRF 040.00	40	60	–	140	110	500	180	73
SRF 063.00	40	80	150	216	153	620	240	111
SRF 100.00	150	250	–	360	260	1000	600	185
SRF 150.00	150	250	350	540	390	1000	600	275

Dimensions in mm

Dimensions of hinged belt

Manufactured of strip steel, the hinged belt plates have roller-formed hinge eyes, and are connected by means of axles to the side chains (which are designed as hollow pin chains), thus forming a hinged belt assembly.

Type	t	S _{SCH}	H _S
SRF 040.00	40	1.5	20
SRF 063.00	63	3.0	35
SRF 100.00	100	3.5	60
SRF 150.00	150	5.0	100

Dimensions in mm

Definitions:

t = Pitch

B_{SCH} = Hinged belt width

S_{SCH} = Plate thickness of the conveyor

H_S = Height of the side rim

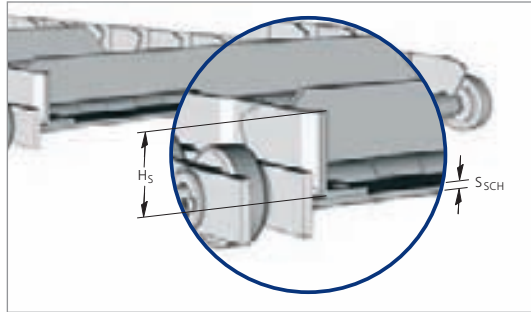
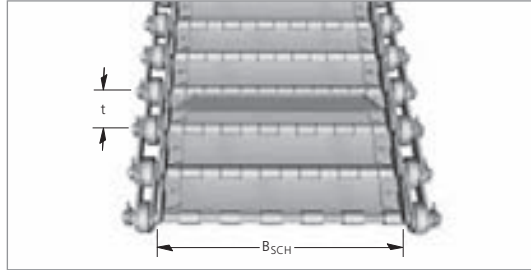

Dimensions as a function of the hinged belt width

Type	B _{SCH}	B _K	B _{AG}
SRF 040.00	150	225	130
	200	275	180
	250	325	230
	300	375	280
	450	525	430
	600	675	580
SRF 063.00	150	270	130
	300	420	280
	450	570	430
	600	720	580
	750	870	730
	900	1020	880
SRF 100.00	150	300	120
	300	450	270
	450	600	420
	600	750	570
	750	900	720
	900	1050	870
SRF 150.00	300	490	250
	450	640	400
	600	790	550
	750	940	700
	900	1090	850

Dimensions in mm

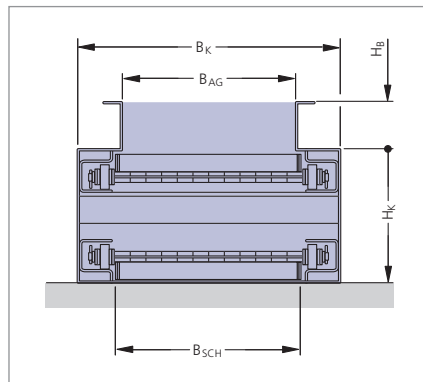

Definitions:

B_{SCH} = Hinged belt width

B_K = Box width

B_{AG} = Feed width

Hinged belt conveyor with WAVE-BELT System

No hinge – low wear

Chips and dirt can accumulate in the hinges with conventional hinge belt conveyors.

The WAVE-BELT System has no hinges on the top side of the belt and is smooth in this area. Chips and dirt cannot get trapped. Due to the "WAVE-FORM" of the belt plates, there is hardly any gap between the plates. **This makes the hinge belts tighter, have a longer service life and require less maintenance.**

The side rims have also been further developed so that almost no conveyed material can get trapped in this area. **In this way, wear and the risk of failure are reduced.**

Hinged belt conveyor with WAVE-BELT System

- Longer service life due to optimized belt design
- Tighter than conventional belts, as there are no hinges
- Extremely stable due to special shaping of the individual belt plates
- Easy to maintain due to bolted and thus very easily replaceable belt plates



■ Due to the special form of the plates, the complete belt is extremely flexurally rigid and highly stressable.



kabelschlepp.de

Fon: +49 2762 4003-0

Enquiry forms – page 504

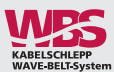

With this sign the use of the latest generation of KABELSCHLEPP hinged belts in conveyors can be recognized.



kabelschlepp.de

Fon: +49 2762 4003-0

Enquiry forms – page 504

Easy replacement of individual hinge belt plates

The belt plates are bolted and can be easily replaced if needed without having to dismantle the complete conveyor belt.

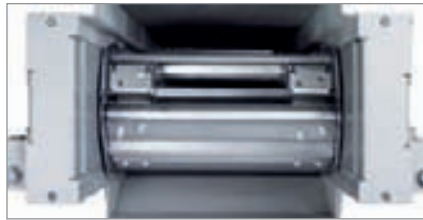
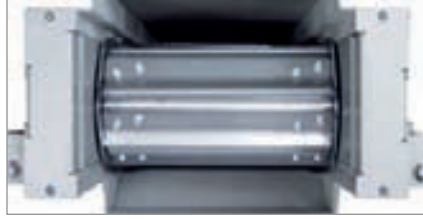

■ Replacement of individual hinge belt plates at the discharge.

Dimensions of hinge belt conveyor WBC 063

Hinge belt

Type	t	S _{SCH}	H _S
WBC 063.00	63	2.5	22.5

Dimensions in mm

- t = Pitch
- B_{SCH} = Hinged belt width
- S_{SCH} = Plate thickness of the conveyor
- H_S = Height of the side rim

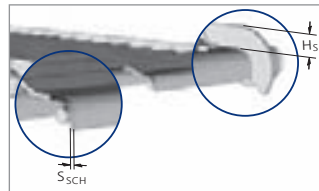
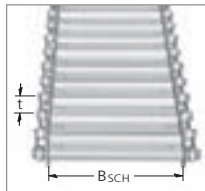

Scraper conveyors

For disposal of small materials

Transport of the material takes place via drivers which push the material along the floor of the housing towards the discharge.

Cooling lubricants are collected in the conveyor housing and can be fed back into the machine circuit via an added-on container or a pumping unit. Our scraper conveyors can be used as stand-alone conveyors at machine tools or as linked conveyor systems.

Depending on the design, the material to be conveyed is brought to the required height at a defined incline and then discharged.



The solution for small and short chips:

- Frequently used for machining of non-ferrous metals
- Can also be used for very hard, short chips
- Casting chips, milling chips and sawing chips

■ Scraper belt conveyors

Structure

- Stable metal plate construction
- Standardized housing cross-section with variable width
- Robust worm gear motor with torque switching
- Customized discharge height
- Customized incline standards = 30°, 45° and 60°
- Floor mounting or as a push-in version into the machine base

Accessory examples

- Motor monitoring systems with current monitoring relay
- Other overload safety devices (on request)
- Coolant container with pump station
- Direct electrical connection to your machine controller
- Other special solutions are available. Please do get in touch with us, we will be happy to advise you.



kabelschlepp.de

Order

Fon: +49 2762 4003-0

LIFE-LINE Safety Cables
TOTALTRAX Complete Systems

Conveyor Systems

Enquiry forms – page 506

Typical designs

Straight design

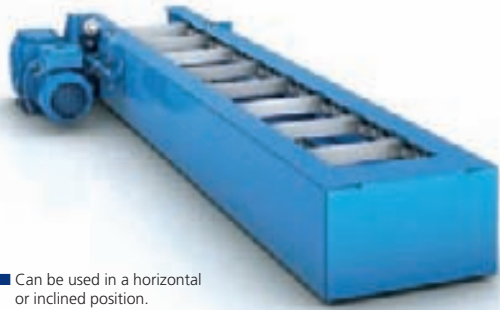

- Can be used in a horizontal or inclined position.
Max incline 45°

Straight/rising design



- Max. incline 45°

Straight/rising/straight design



- Max. incline 60°



Scraper conveyors

For disposal of small materials

Types and main areas of application

KRF 040 – the “classic” scraper conveyor

Pitch of the scraper belt $t = 40$ mm

Our standard scraper conveyor for smaller machine tools and small quantities of chips.



KRF 063 – for somewhat “bigger” tasks

Pitch of the scraper belt $t = 63$ mm

For larger machines and larger quantities of chips.



KRF 100 – the “strongest” one we build

Pitch of the scraper belt $t = 100$ mm

Special solution for very large quantities of chips.

Standard dimensions

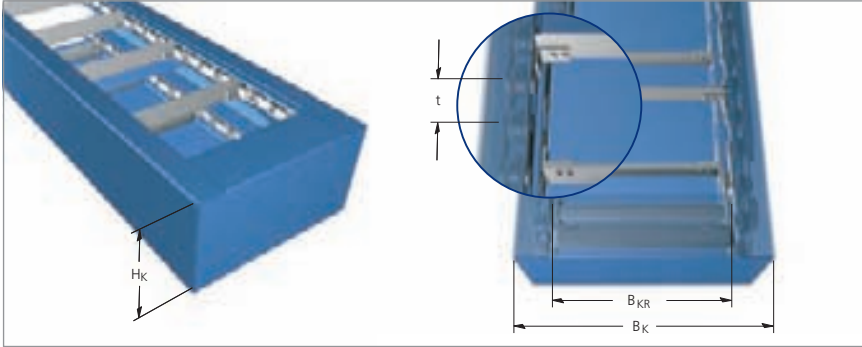

Type	Pitch t	Box height H _K	Scraper belt width B _{KR}	Box width B _K
KRF 040.00	40	140	150, 200, 250, 300, 450, 600	B _{KR} + 90 mm
KRF 063.00	63	216	150, 300, 450, 600, 750, 900	B _{KR} + 120 mm
KRF 100.00	100	420	150, 300, 450, 600, 750, 900	B _{KR} + 150 mm

Special dimensions on request.

Dimensions of conveyor housing

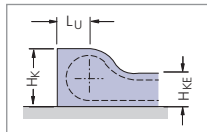
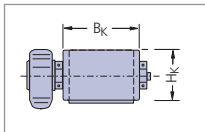
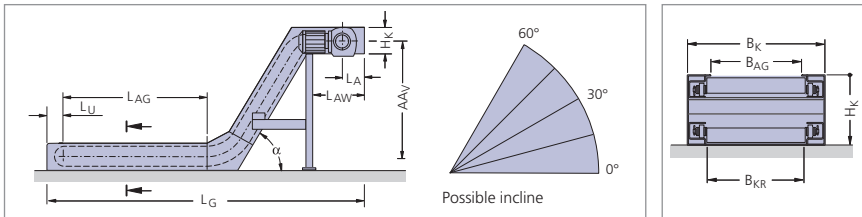

Type	H _K	H _{KE}	L _{AW}	L _A	L _U min
KRF 040.00	140	110	500	180	73
KRF 063.00	216	153	620	240	106
KRF 100.00	360	260	1000	600	215

Dimensions in mm

Variable dimensions:

B_{KR} = Scraper width
B_K = Box width
B_{AG} = Feed width

AA_V = Distance between axles, vertical
L_{AG} = Feed length
L_{AW} = Discharge length
L_G = Total length of the conveyor
α = Incline

Design-dependent dimensions:

H_K = Box height
H_{KE} = Retracted box height
L_A = Length of the tail (discharge, incl. tensioning distance)
L_U = Length of the tail (feed)



Modular conveyors

Hinged belt conveyors with modular construction

Our hinged belt conveyors are also available with modular design construction. Thanks to the use of standard subassemblies, you can benefit from significantly shorter delivery times than with conventionally constructed conveyors.

The conveyors are delivered ready for operation.

The hinged-belt conveyors feature three individually configurable subassemblies:

- reversing unit
- feeding section
- discharge unit

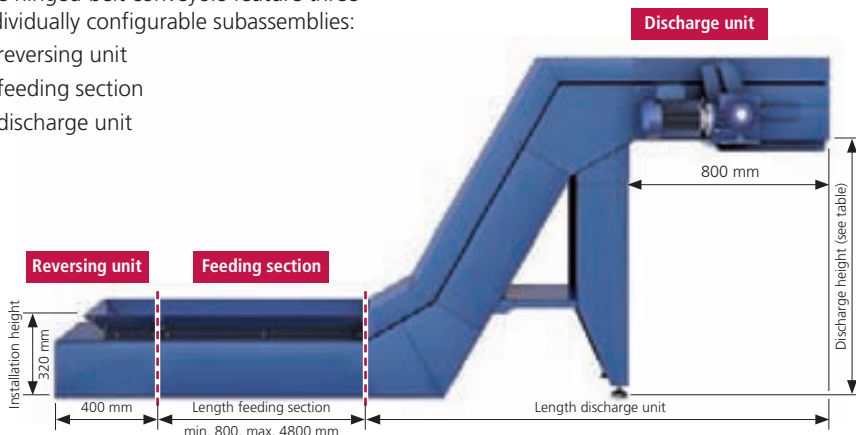

Dimensions of standard modules

On the basis of **conveyor type SRF 063 (belt width 300 mm)**, the standard modules can be assembled and delivered on short notice. Fixed discharge heights cover the most common container sizes. With length sections of 400 mm, the feed length can be adapted to various machines.

Should you require a conveyor system with different dimensions, please contact us – we are constantly expanding our range of standard modules.

Modular hinged belt conveyors with modular system design

- short delivery times
- cost-efficient
- configurable with standard subassemblies
- delivered ready for operation (no on-site assembly necessary)
- stable conveyor housing (welded modular connections)

Standard subassembly	Discharge height H_f	Belt width B_{SCH}	Box width B_K	Panel height H_B	Length L	Installation height H_E
Discharge unit 800	1115	300	420	80	1845	–
Discharge unit 1200	1460	300	420	80	2045	–
Discharge unit 1600	1810	300	420	80	2245	–
Feeding section 800	–	300	420	80	800	320
Feeding section 1200	–	300	420	80	1200	320
Feeding section 1600	–	300	420	80	1600	320
Reversing unit	–	300	420	80	400	320

all dimensions in mm

Belt conveyors

The all-rounders – also for parts with sharp edges

Our belt conveyors are predominantly used on punch-nibbling machines, for transporting punching scrap and punching trimmings.

However, other parts can also be transported, such as waste parts from plastic injection machines. The transport belt of the conveyor is resistant to oil and grease.



■ Belt conveyors

Structure

- Housing made of steel plate
- Oil-resistant belt
- Protective motor switch
- Convex return shafts
- Shafts with ball bearings
- Adjustable belt tension

The universal transport solution, for applications where no cooling lubricant is present.

- Also suitable for parts with sharp edges
- Not suitable for transporting hot chips



Standard design



- Standard design**
 Can be used in a horizontal or inclined position. Max incline 30°

Standard dimensions

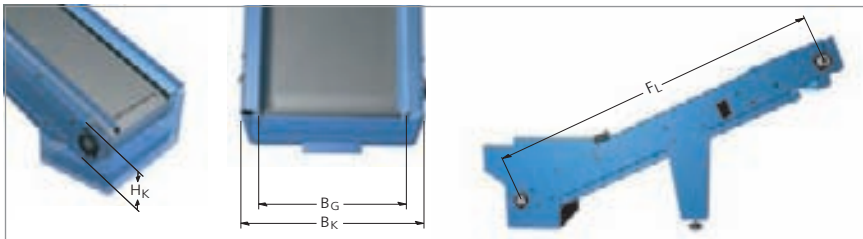

Type	Box height H_K	Belt width B_G	Box width B_K	Maximum conveying length F_L
GBF	104	150, 200, 250, 300, 450, 600	$B_G + 50$	5000

Special widths on request.

Dimensions in mm



Selection

BASIC LINE

BASIC LINEPLUS

VARIO LINE

TUBE SERIES

3D LINE

STEEL LINE

Order

LIFE-LINE Safety Cables
TOTALTRAX Complete Systems

Conveyor Systems

Guideway protection systems

Perfect protection for guideways on machine tools



Telescopic covers

page 460

Perfect protection for guideways on machine tools



Way wipers

page 474

The cleanup crew



Link apron covers

page 483

Solutions for limited spaces



Bellows

page 487

Guideway protection solutions with very little compression



Conical spring covers

page 489

Protection under extreme conditions



Roll-up covers

page 492

Protection in a minimum of space

Telescopic covers

Perfect protection for guideways on machine tools

Wherever guideways on machines have to be protected, we have a suitable solution. Our guideway protection systems boast a high degree of operational reliability, a long service life, and make use of innovative technical solutions.



Every production machine requires protection for its guideway

Today, modern machine tools process workpieces at ever-greater cutting and travel speeds. The protection of guideways, measuring systems, drive elements and other vulnerable parts is absolutely essential.

Accelerations and speeds of machines are constantly increasing. Telescopic covers must also be able to cope with these challenges. This is where telescopic covers with harness mechanisms are used.



■ Telescopic cover for lathes



■ Telescopic cover at a milling machine

From individual manufacture to series production – we have a solution

The number of varieties is immense, no cover for a machine is exactly the same as any other.



■ Telescopic cover with flat shape on a boring machine

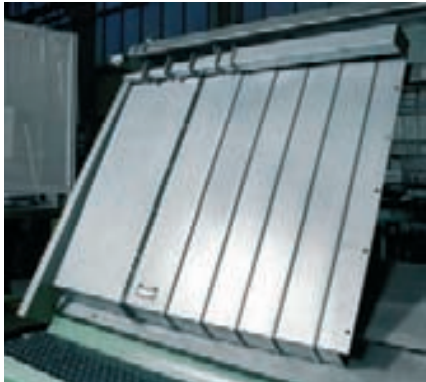

■ Special form of an inclined bed cover on a test framework

Designs and areas of application

Until the 1970s, telescopic covers seldom moved in speed ranges any greater than 15 m/min.

The expansion and compression of the individual boxes took place sequentially. Due to the low speed, there was hardly any impact pulse that caused interfering vibrations.

Over the years, however, Improvements in drive technology have increased the travel speeds of the machines and thus also the speeds of the cover.

At high running speeds the impact pulses affecting the covers is enormous. This creates high impact noise and machine vibration. Furthermore extreme mechanical stress is exerted on the telescopic cover.

The landscape for telescopic covers has changed greatly in the last few years.

“Old” designs are less and less in demand, with modern concepts such as covers with differential drives taking their place.



■ Cross-beam cover at a milling machine



■ Telescopic cover for wheel grinders

Telescopic covers are generally produced from cold-rolled uncoated thin plates in thicknesses from 1 to 3 mm.

In case of extremely aggressive environmental conditions (e.g. aggressive cooling lubricants), corrosion-resistant stainless steel plates may also be used.

KABELSCHLEPP telescopic covers also allow the use of semi-finished products with surface finishings such as:

- Plates with pure zinc coatings
- Plates with zinc/nickel coatings
- Plates with lead/zinc coatings

This ensures substantial protection against corrosion.



Telescopic covers

The speed is decisive

At speeds below 15 m/min a telescopic cover can still be built in the conventional form of box synchronization. At high running speeds the inevitable impact pulses lead to vibrations and clearly audible impact noise.

So-called differential drives serve to synchronize the boxes and eliminate impact pulses. KABELSCHLEPP has decided on the tried and proven harness mechanism principle for which special materials are used.

Telescopic cover with damping elements

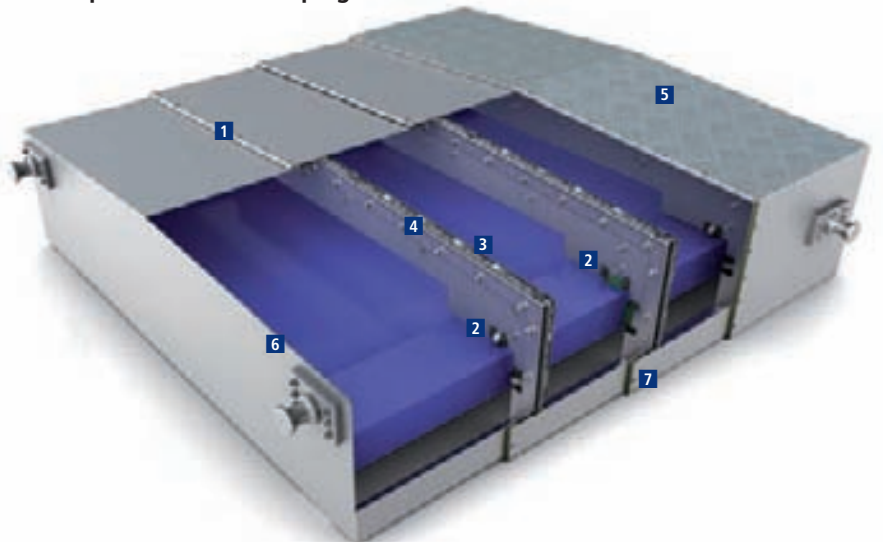

1 Wiper systems in various designs



2 Rollers



2 Sliders



3 Gully in various designs

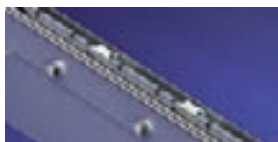

4 Damping systems in various designs



5 Structural metal plates to prevent slipping (on the largest box)



6 Lifting element



7 Locking system

Travel speed	Damper elements / harnesses
Up to 15 m/min	Not required
Up to 30 m/min	Damper elements
Up to 60 m/min	Damper elements / harnesses

The use of damping elements depends on the travel speed and the moving mass. The information in the table should therefore only be viewed as guide values.

Telescopic covers

Selection

BASIC LINE

BASIC LINE PLUS

VARIO LINE

TUBE SERIES

3D LINE

STEEL LINE

Order

kabelschlepp.de

Fon: +49 2762 4003-0

LIFE-LINE Safety Cables
TOTALTRAX Complete Systems

Conveyor Systems

Guideway
Protection Systems

Enquiry forms – page 510

463

Telescopic cover with harness mechanism

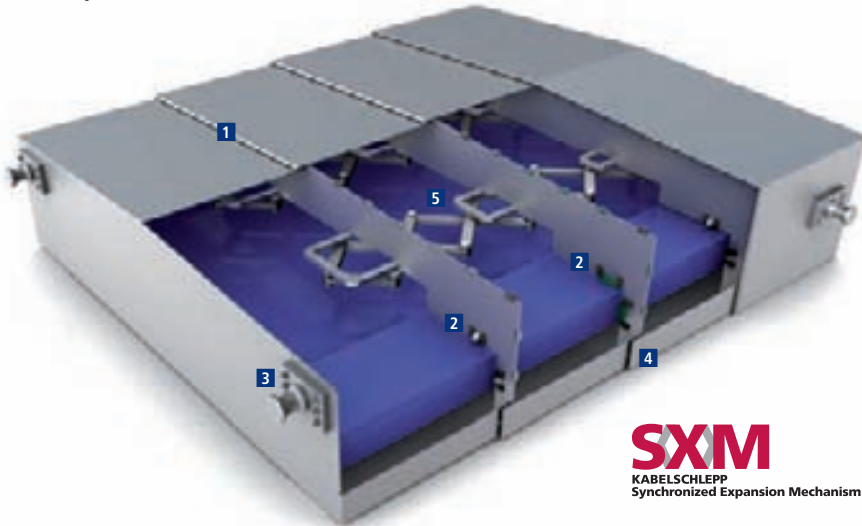

SXM
KABELSCHLEPP
Synchronized Expansion Mechanism



1 Wiper systems in various designs



2 Rollers



2 Sliders



3 Lifting element



4 Locking system



5 Synchronising device (harnesses) for fast-running telescopic covers

SXM – Mechanical elements with harnesses

KABELSCHLEPP sets the mark

To ensure impact-free expansion / compression of telescopic covers, they are used with so-called synchronisers (harnesses).

As a result, all of the cover boxes move evenly during expansion and compression. The individual boxes move relative to each other only at a differential speed.

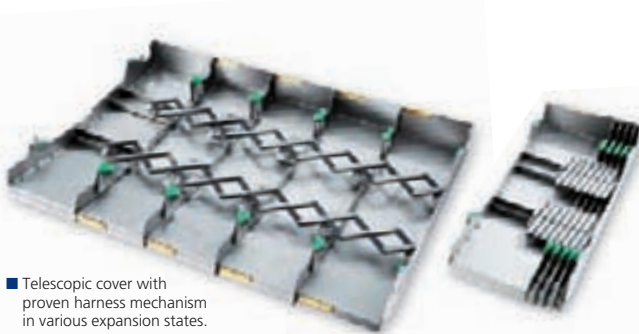

- Telescopic cover with proven harness mechanism in various expansion states.

SXM
KABELSCHLEPP
Synchronized Expansion Mechanism

SXM – Synchronized Expansion Mechanism.

The KABELSCHLEPP harness technology is used wherever you find this symbol.

Telescopic covers with harness mechanisms have many advantages:

- High travel speeds up to 200 m/min are possible.
- **Acceleration forces** and speeds are **uniformly distributed across all the plates**. This also applies to the resultant inertial forces.
- The **force peaks** that would normally occur when the telescopic covers dashed against each other **do not occur**.
- The disruptive **impact pulse** of the boxes is **eliminated**.

Cover with two harnesses

This solution has been developed for travel speeds greater than 100 m/min.

Two harnesses ensure synchronization. In the example shown here the cover plates are made of 1 mm thick stainless steel.

The cover plates are riveted to the rear wall. Welding and the resulting heat effects have been avoided. Only the wiper is spot-welded.



SXM
KABELSCHLEPP
Synchronized Expansion Mechanism

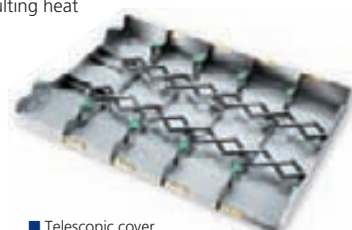

- Telescopic cover with proven harness mechanism

Cover with one harness

This particularly lightweight solution has been developed for "small" machine tools. The cover plates are made of 1 mm thick normal steel.

The travel speed in this special application is only 30 m/min. The harness mechanism serves to ensure synchronization, however, and the reduced mass of all the elements means that it was possible to develop an especially cost-effective solution here.

SXM
KABELSCHLEPP
Synchronized Expansion Mechanism



- Telescopic cover with only one harness

Damping brake for telescopic covers

Higher surface quality with push and pull-damped telescopic covers

During travel of telescopic covers, impact pulses are generated when the boxes strike against the damping elements. In order to ensure high surface quality during machining, strong impact pulses must be avoided.

The damping brake achieves soft damping of the accelerated masses.

The surface quality of workpieces is positively influenced in particular by soft impact pulses and a longer damping distance.



Damping brake for telescopic covers

- damping via braking effect
- especially for large covers
- damping during expansion and compression
- adjustable damping

Minimized impact pulse through defined braking process

Impact pulses are reduced by a defined braking process, and the deceleration path is lengthened by several centimeters compared to buffer solutions. The end result is a soft damping.

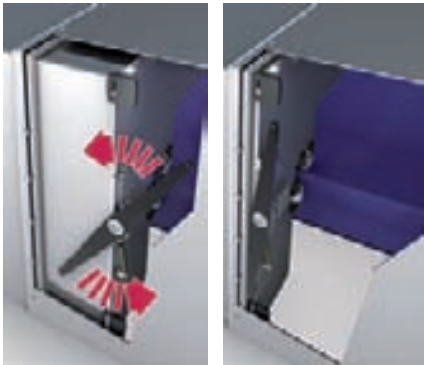

■ The braking of the boxes minimizes shocks

Damping during expansion and compression

The damping brake works during box expansion and compression of the boxes. The soft damping reduces the load on the material and increases the service life.

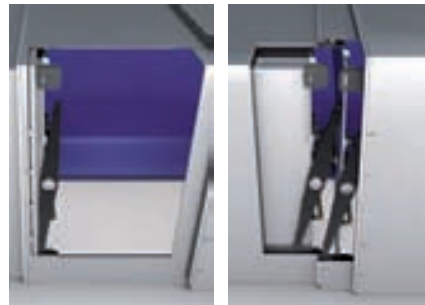

■ Damping in both directions



Telescopic covers

Perfect protection for guideways on machine tools



Photograph: Heinrich Georg GmbH Maschinenfabrik

kabelschlepp.de

Fon: +49 2762 4003-0

Enquiry forms – page 510

Designs

Machine tools come in a wide variety of designs. That is why a modern lathe needs another type of telescopic cover than, for example, a large

bed-type milling machine. The following designs provide an overview of typical designs.

Flat shape

The U-shaped design is generally used in a horizontal, lying position for milling table guides. With this design the maximum width of the telescopic cover should be limited to 1.5 m.

Roof shape, centric (eccentric)

This design is always advisable when cooling lubricants are used. The inclined surface allows the water – and naturally also the chips – to run off more easily. With large covers (> 3 m width) for reasons of stability, etc. at least three roof angles should be provided.

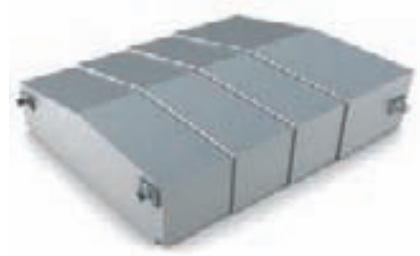

Flattened roof shape

The flattened roof shape is a special construction method with two roof angles. Primarily for dry operation and widths > 3 m.

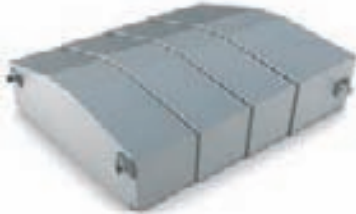

Shape with incline to one side

The shape with incline to one side has a special roof shape. Depending on the possible incline, covers can be constructed with widths of up to 1.5 m. This shape is likewise a recommended solution when large amounts of coolant are present.

Depending on the angle of incline, this form also helps to discharge coolants / chips.

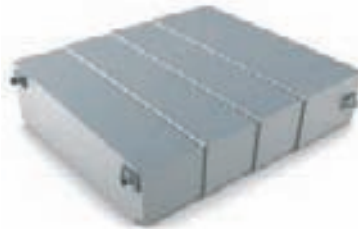

Vertically-installed telescopic cover

Standing covers are used on larger machine tools, mostly in the area above and below the cross beam. They can take many different shapes.



Blind cover

With blind telescopic covers, the cover plates move in separate guide rails, each of which is mounted on the machine at the sides. It is used exclusively in a vertical arrangement. The guide rails are generally made of brass.



Cross-beam cover

These covers are predominantly used on large gantry machine tools on a cross beam to the left and right of the support. The boxes are suspended vertically and protect the support guides from chips and cooling lubricants.



Tubular cover, polygonal cover

Tubular covers or covering shafts, spindles, etc. They can be made either with a round or a polygonal shape.



Wipers on telescopic covers

Wipers on telescopic covers keep the cover boxes clean and prevent the penetration of dirt and chips.

Welded-on and riveted-on wipers

With these types the support profile is spot-welded or riveted to the cover box.

Type MA 8 / MA 12

These wipers consist of an NBR profile vulcanized onto a steel strip.

Necessary calculated distance of the cover plates 2.5 to 3.5 mm.

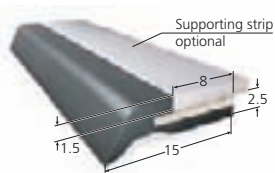

■ Wiper type MA 8

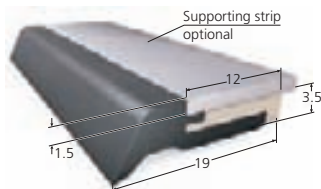

■ Wiper type MA 12

Type MA 8S / MA 12S

Wipers MA 8 and MA 12 are covered with a protective strip for protection against hot chips.

Necessary calculated distance of the cover plates 3.5 to 4 mm



■ Wiper type MA -S

Type MA 12.1 / MA 18

A specially-milled steel plate profile is spot-welded to the boxes and a PUR wiper lip is inserted.

Necessary calculated distance of the cover plates 3.5 to 5.5 mm.

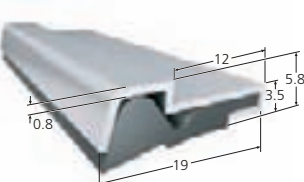

■ Wiper type MA 12.1

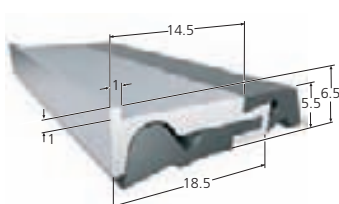

■ Wiper type MA 18



kabelschlepp.de

Fon: +49 2762 4003-0

Enquiry forms – page 510

Welded-on and riveted-on wipers

Steel plate wiper made of spring band steel

A specially shaped, approximately 0.4 mm thick, approximately 25 mm wide band of stainless spring band steel is spot-welded to the cover plate. This wiper is recommended for dry machining.

Necessary calculated distance of the cover plates 1 mm.

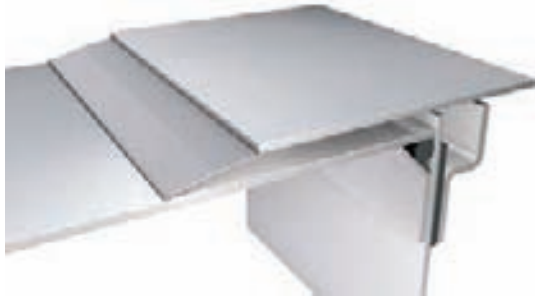

Types with replaceable wiper lips – the new generation

The replaceable wiper with a PU lip

This new generation of wipers can be replaced directly on the machine, without disassembling the telescopic cover.

The wiper lips have good gliding characteristics and are also usable where little lubricant is generated, e.g. on machine tools.

Turn-lock fasteners fasten the wiper to the cover plates. With a 90° turn of the turn-lock fasteners the wiper is locked or released. In this way the system can be easily switched out for fresh parts.

Necessary calculated distance of the cover plates 4 mm (VA 12 G) and 6 mm (VA 17 G).



■ Wiper type VA 12 G

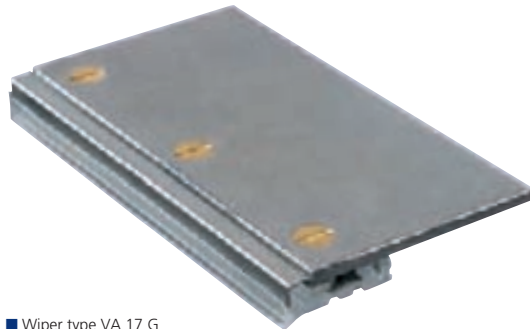

■ Wiper type VA 17 G

Damping elements on telescopic covers

Telescopic covers with travel speeds greater than 15 m/min must be provided with dampers in order to reduce impact pulses.

Wiper type MA 18 with damping

The support profile is made of aluminium and is screwed or riveted on. The wiper lip is identical to MA 12.1. The special damping profile can be installed in the rear aperture formed onto the support profile.

Necessary calculated distance of the cover plates 5.5 mm.



Brass strips with damping

Brass strips are used primarily on standing covers. The damping profile described above can likewise be mounted on an appropriately drawn brass profile.

Necessary calculated distance of the cover plates 5.5 mm.



Progressive damping element

In order to reduce impact pulses effectively, progressive damping elements can be installed in the rear walls of the covers. Depending on application and running speed the number of dampers is varied in order to achieve an optimal result.



Damping elements for compression

Damping elements that only work during expansion require an additional element for compression. Here simple rubber buffers mounted at an appropriate point on the rear wall have proven themselves over many years.



Splash- and hose-proof protection on telescopic covers

Over time cooling emulsion and fine chips can be “pumped” under the individual boxes and make it over the rear wall into the machinery space that is being protected. In many cases this is undesirable. Machine tools with hydrostatic bearings require “watertight” covers.

Gullies for telescopic covers

In order to catch coolant and chips that make it over of the rear wall. This gully allows the fluids to be drained off to the sides.

Aluminium gully type AL 19

This gully is an extruded aluminium profile which is screwed onto the rear walls of the cover. The cover plate is bent downwards so that it projects into the gully. This allows the coolant between the plates to flow into the moulded gully. Condensation water that forms under the cover plates is wiped off by a lip and drained into gullies to the front and back. This makes it possible to achieve a very high level of waterproofing.



Gully type ST 05

This gully is screwed onto the rear wall. This has the advantage of, among other things, meaning that galvanized metal plates can be used (no welding necessary).



Condensation gully type ST 05 K

This gully is based on the proven type ST 05. An upward extending sealing membrane made of flexible synthetic moves in both directions catching the condensation and directing it into the drain gutters. From there it flows automatically into the side drains.



Telescopic covers



Selection

BASIC LINE

BASIC LINE PLUS

VARIO LINE

TUBE SERIES

3D LINE

STEEL LINE

Order

kabelschlepp.de

Fon: +49 2762 4003-0

LIFE-LINE Safety Cables
TOTALTRAX Complete Systems

Conveyor Systems

Guideway Protection Systems

Enquiry forms – page 510



Rollers and sliders on telescopic covers

The individual boxes of telescopic covers are supported by rollers or sliders on the guideways or corresponding supplementary guides. In addition, there are various solutions depending on the qualities of the way:

Plastic rollers

- Gentle rolling on the guideway
- For low travel speeds



Steel rollers

- For high support loads
- For high travel speeds



Plastic sliders

- Good sliding characteristics on the guideway
- For high travel speeds
- Can also be used for linear guides

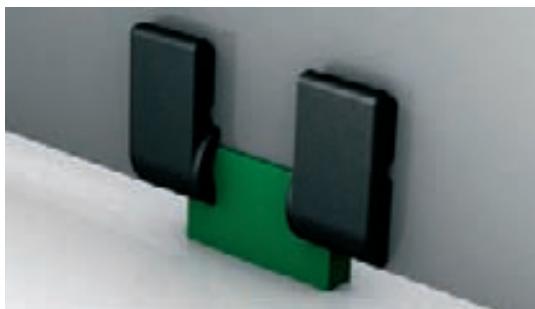

Metal sliders

- For high support loads
- For low travel speeds



CROSS-COVER covers

Even longer service lives for horizontal machines

Wherever for example machining spindles of horizontal drilling machines move with high accelerations and speeds, horizontal and vertically moving cover elements are needed.

With the second CROSS-COVER generation you likewise receive a ready-to-install cover unit that is movable in two dimensions. They are adapted individually to your application and delivered ready to install.

Our reworking of its proven design has improved its dynamic characteristics and extended its service life.



Re-Design CROSS-COVER

With the second CROSS-COVER generation the use of gliding and guide elements and the systematically weight-optimized design have made possible even higher travel speeds.

In addition to improvement of the dynamic characteristic values through reduction of the moving masses, the covers are even more durable. They provide the same high penetration resistance as the service-proven system.

Re-Design CROSS-COVER

- higher travel speeds and accelerations possible
- longer service life
- lighter thanks to optimized design
- Protection against spray water according to IP X5
- Size selections available on short notice



■ CROSS-COVER in various expansion states

SXM
KABELSCHLEPP
Synchronized Expansion Mechanism

SXM – Synchronized Expansion Mechanism

Impact-free travel of the cover elements

To ensure impact-free expansion / compression, synchronizers (harnesses) are also used in the revised design.

Protection against spray water acc. to IP X5

The CROSS-COVER covers meet the requirements of protection class IP X5 (Ingress Protection – protection against hose water).

Way wipers on guideways

The cleanup crew

Way wipers are essential to keep the guideways in a proper functional state, and thus to keep the machine tool permanently in operation. Even if the guideways are already protected by a telescopic cover, it is necessary to wipe fine, penetrating particles off of the vulnerable ways.



kabelschlepp.de



■ Harnessed way wipers



■ Cast wiper with steel support strip



■ Way wipers in a modular system



■ BAY-WIPE way wiper with optimised corner design.

kabelschlepp.de

Fon: +49 2762 4003-0

Enquiry forms – page 514

475

Overview and delivery forms

Harnessed way wipers – proven in millions of applications

Available in a wide variety of shapes, harnessed according to your specifications, in bar form or available ex-stock.

Further Information can be found on page 476.



Way wiper BA 65

Cast wiper with steel support strip, available ex-stock in bar form.

Further Information can be found on page 478.



Way wiper BA 115 – with extra-long lip

Highly-flexible cast wiper with steel support strip, available ex-stock in bar form.

Further Information can be found on page 479.



Way wipers in a modular system – the clever solution

The most economical alternative to cast wipers.

Further Information can be found on page 480.



Way wiper types BA and BAS

Wipers of this type have a replaceable lip and guarantee high form stability and mechanical loading capacity. They are manufactured in custom forms according to your specifications. Available as bar material ex-stock.



Note: Reduce costs

With types BA and BAS the wiper lip is replaceable. In case of wear, only the lip has to be exchanged; the support profile can remain in use.

Properties

- Temperature range – 40 °C to 100 °C
- Support material: Aluminium
- Wiper lip material: Polyurethane
- Largely resistant to oils, greases, alkalis and water
- Pretension approx. 2 mm
- Replaceable wiper lip
- Standard length of bar material: 1000 mm



■ Inside or outside wiping forms are possible



Dimensions and types

Type BA

Way wipers of this type are used mainly in those cases where installation conditions are restrictive, or where the wipers are additionally protected by means of a telescopic cover, a bellows, a link apron cover, or where no chips occur.

Type	Installation height H (clamped in position)
BA 18	17.5
BA 25	23.5

Standard length: 1000 mm

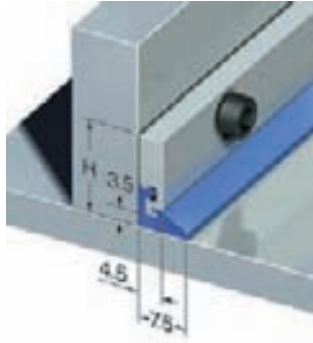

Type BAS

In this type series, the light metal support provides protection for the wiper lip. It is used primarily in the case of direct incidence of chips (no hot chips).

Type	Installation height H (clamped in position)
BAS 18	17.5
BAS 25	23.5
BAS 40	39.5

Standard length: 1000 mm

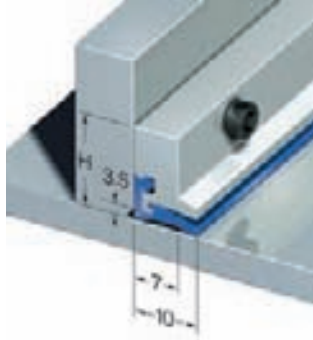

Pre-wiper for protection of the guideway

To protect the wiper lip from hot chips, and to remove coarse and stubborn dirt from the guideway, the way wiper must be fitted with a pre-wiper made from stainless spring steel or brass.

The pre-wiper and its corresponding light metal clamping strip are affixed to the machine component with the fastening screws of the wiper.

For straight way wipers with a corresponding hole pattern (distance between holes ≤ 80 mm), the clamping strip is not required.

Way wiper BA 65 – bar material

Wipers of this type are compact and are notable for high shape accuracy and dimensional accuracy. It is manufactured in various forms, thus guaranteeing high repeatability.

Properties

- Temperature resistance – 40 °C to + 100 °C, briefly up to 140 °C
- Support material: Steel
- Wiper lip material: Abrasion-resistant synthetic rubber (NBR)
- Resistant to standard oils, greases, acids and bases
- Resistant to microorganisms

Dimensions

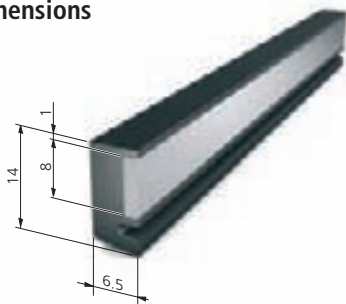

■ Way wiper BA 65-14

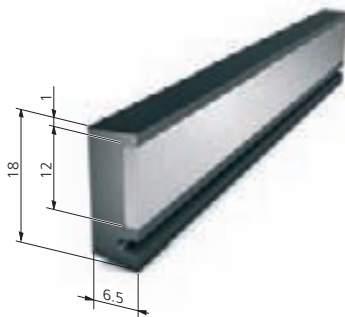

■ Way wiper BA 65-18

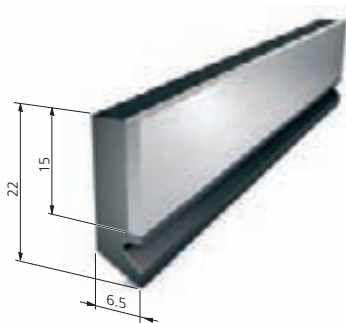

■ Way wiper BA 65-22



■ Way wiper BA 65-25

Type	Pretension (max.)
BA 65-14	1 mm
BA 65-18	1 mm
BA 65-22	2 mm
BA 65-25	1 mm

Length: 500 mm

Way wiper BA 115 – bar material

Highly flexible wiper with a max. pretension of 4 mm. It is likewise manufactured in various forms, guaranteeing high repeatability.

Properties

- Temperature resistance – 40 °C to + 100 °C, briefly up to 140 °C
- Support material: Steel
- Wiper lip material: Abrasion-resistant synthetic rubber (NBR)
- Resistant to standard oils, greases, acids and bases
- Resistant to microorganisms

Dimensions

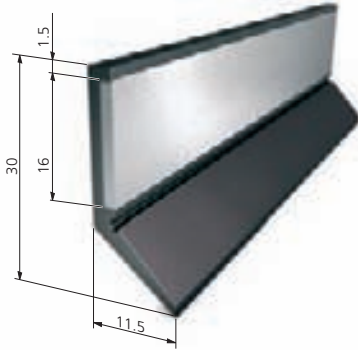

■ Way wiper BA 115-30

Type	Pretension (max.)
BA 115-30	4 mm

Length: 500 mm

kabelschlepp.de

Fon: +49 2762 4003-0

Enquiry forms – page 514

Way wiper BA 65 VARIO

The most economical alternative to cast wipers – even for small quantities. On request we also manufacture them according to your specifications – custom tailored for your application. BA 65 VARIO way wipers are optionally available as complete wipers, or as individual wiper lips in bar form for your own harnessing.



So-called “cast wipers” are wipers consisting of a piece of neoprene rubber vulcanised onto a steel support profile. They are produced in specially-manufactured injection moulds. Larger quantities are essential, as the tool costs must be offset by the number of parts produced.

For the wiper system **BA 65 VARIO** no special tools are required: A pre-finished profile of synthetic rubber is custom-tailored. The support profile – usually made from metal – can be produced on a laser or nibbling machine.

Thus smaller quantities can be produced in this way at a reasonable cost.

Properties

- Temperature resistance – 40 °C to + 100 °C, briefly up to 140 °C
- Support material: Steel, stainless steel
- Wiper lip material: Abrasion-resistant synthetic rubber (NBR)
- Resistant to standard oils, greases, acids and bases
- Pretension of the wiper lip: max. 1 mm
- Resistant to microorganisms



Dimensions

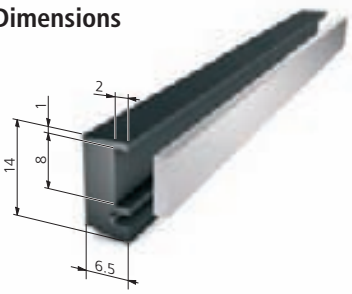

Way wiper BA 65-14 VARIO

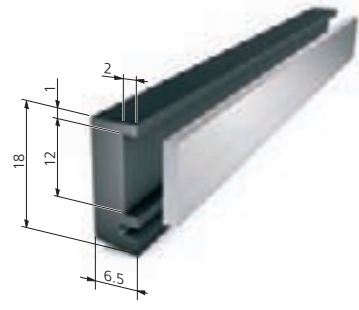

Way wiper BA 65-18 VARIO

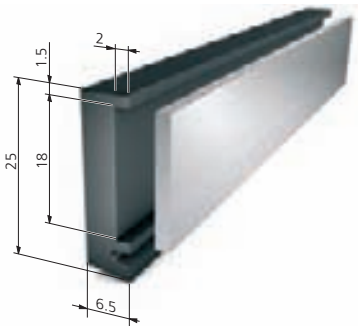

Way wiper BA 65-25 VARIO

Type	Pretension (max.)
BA 65-14	1 mm
BA 65-18	1 mm
BA 65-25	1 mm

Length: 500 mm

Delivery options

1. Construction set as individual parts

The support material and wiper lips are produced according to your specifications, and put together as a construction set.



Easy assembly of the individual parts

2. Ready-to-install wiper system

All parts are supplied affixed to the support profile.



Ready-to-install wiper system

3. Separate wiper lip

If your production department can produce the required support plates itself, you can order the wiper lip from us separately. The delivery length is 500 mm.

It can be ordered as follows:

-pcs. wiper lip BA 65-14 material no. 79000
-pcs. wiper lip BA 65-18 material no. 79001
-pcs. wiper lip BA 65-25 material no. 79003



Wiper lip bar material

Way wiper BAY-WIPE

Wiper with double action

BAY-WIPE by KABELSCHLEPP does, what didn't seem possible up to now: A way wiper system that serves to wipe off oil inside while simultaneously removing foreign particles and coolants outside. In this way it protects particularly hydrostatic guideways by preventing the escape of lubricants.

Many wiper systems have problems at the point where a hydrostatic guideway goes round a corner. Rounded or bevelled corners on guideways are often problem areas, because the wiper elements cannot follow the profile closely enough.

Our BAY-WIPE system now has these problem areas perfectly under control. Thanks to its optimised corner elements, which follow the contours of the path exactly, the guideway is wiped clean in both directions.

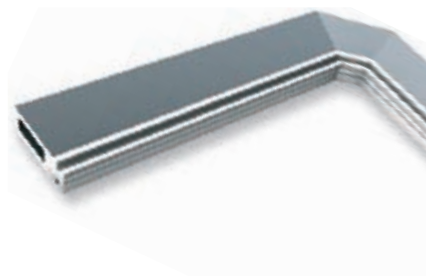

Properties

- Aluminum support profile with PUR wiper lip
- Wiper with double action: Wipes inside and outside
- Has separation effect by wiping on both sides
- Extremely low oil loss
- Prevents the invasion of foreign material
- Optimal regularity of pressure through minimum form deviation (die casting)
- Also provides seal at guideway protection bevel by conforming to shape
- Simple production, few parts

Dimensions

- Pretension: 0.4 mm
- Length: 516 mm

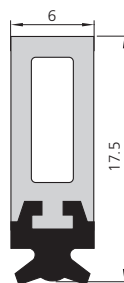

Intelligently designed, individually produced

The wiper lip of the BAY-WIPE was developed at the Institute for Machine Elements (IMA) at the University of Stuttgart. KABELSCHLEPP participated in this research project, and put the results into practice in a consistent manner.

A wiper lip that works in both directions is affixed directly to the support profile by means of a plastic injection moulding process. The straight sections of this profile, which have been cut to length, are then non-positively joined with pre-assembled corner elements. This allows a wiper system to be created from the individual parts, exactly suited to the contours of the guideway.



Link apron covers

Solutions for limited spaces

Link apron covers can be used anywhere where, for reasons of space, it is not possible to use telescopic covers. They lie directly on the guideways and can hang down freely at the end of the path, or be screwed on or wound around without any special guides.



Properties

- Small space requirement
- Protection against chips and lubricant
- Splash- and hose-proof
- Low weight
- Long service life
- Heat-resistant to 100 °C over extended periods
- Customized end attachment
- All link apron covers can be supplied with a roller device
- Lateral guides are not necessary
- Short delivery time
- Attractive price/performance ratio





Link apron covers

Solutions for limited spaces

Designs

Design 1

Lightweight, highly flexible solid profile link apron covers, thin design.

$B_{\min} = 100 \text{ mm}$

$B_{\max} = 950 \text{ mm}$

$R_{\min} = 25 \text{ mm}$

Weight = 5.6 kg/m^2

Solid aluminium profile $19 \times 3.0 \text{ mm}$
with PU connecting elements



Design 2

Robust solid profile link apron covers,
for high stress.

$B_{\min} = 100 \text{ mm}$

$B_{\max} = 2950 \text{ mm}$

$R_{\min} = 50 \text{ mm}$

Weight = 14.2 kg/m^2

Solid aluminium profile $20 \times 5.5 \text{ mm}$
with PU connecting elements

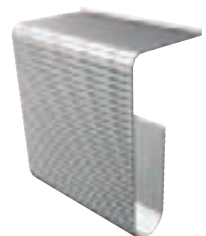

Design 2N

Lightweight, stable hollow profile link apron covers,
extremely stress-resistant, even in large widths.

$B_{\min} = 100 \text{ mm}$

$B_{\max} = 2950 \text{ mm}$

$R_{\min} = 50 \text{ mm}$

Weight = 10 kg/m^2

Hollow aluminium profile $20 \times 5.5 \text{ mm}$
with PU connecting elements



Design 3

Flexible solid metal link apron cover,
with hinges and one-sided bend radius.

$B_{\min} = 100 \text{ mm}$

$B_{\max} = 2000 \text{ mm}$

$R_{\min} = 60 \text{ mm}$

Weight = 16.5 kg/m^2

Hollow aluminium profile $18.5 \times 6.8 \text{ mm}$
with integrated hinge

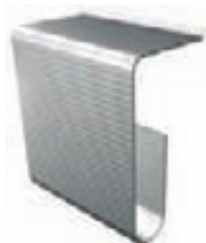

Fastenings / connecting elements

Examples of fastening profiles



■ Standard end profile



■ Standard profile with mounting bracket



■ Straight end profile

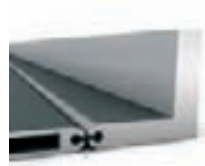

■ Angle fastening profile

Installation variants

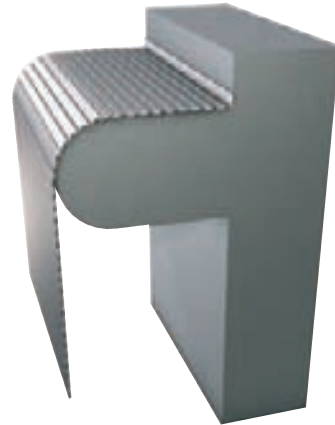
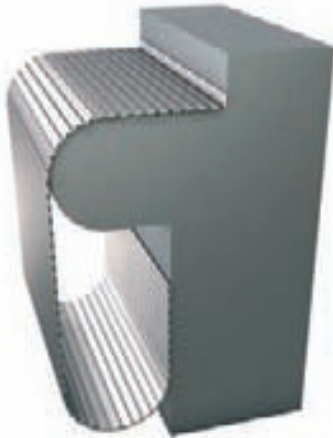

Roller devices

All link apron covers can be rolled up like a window blind.

They can be driven with spring or electric motors.

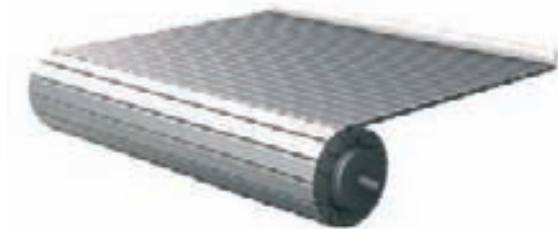

Steel link apron covers – FLEX-COVER

Lighter, tougher, more economical



The FLEX-COVER link apron cover represents a small revolution: it is made from heat steel, making it 3 times more robust than aluminium – but weighing the same. Its construction means that penetration by fluids and chips is virtually impossible. The individual elements roll against each other in the radius of the lamellas.

There is hardly any wear, as there is no friction, and no bendable connection elements that could be exposed to fatigue.

FLEX-COVER gives you improved properties with no increase in weight, and at a considerably lower price.

The specially-milled sheet steel lamellas are held together by a slotted plastic tube, which is itself affixed by means of spring steel clips.



Properties

- Rustproof steel lamellas
- 3 times greater resistance to flying chips
- Each lamella has a completely smooth surface
- Hardly any wear of steel or plastic parts
- Virtually no penetration by chips or fluids

$B_{\min} = 200 \text{ mm}$

$B_{\max} = 2000 \text{ mm}$

$L_{\max} = 2500 \text{ mm}$

$R_{\min} = 50 \text{ mm}$

Weight = 10 kg/m^2

Heat resistance: approx. $80 \text{ }^\circ\text{C}$

Travel speed: 1.5 m/s

Acceleration: up to 15 m/s^2 , depending on the specific application

Bellows

Guideway protection solutions with very little compression

KABELSCHLEPP bellows are used on all kinds of machine to provide protection for guideways and spindles, in those cases where no hot chips are present and accessibility is not a requirement.

Bellows can be individually produced from a range of different materials, depending on your specific requirements.

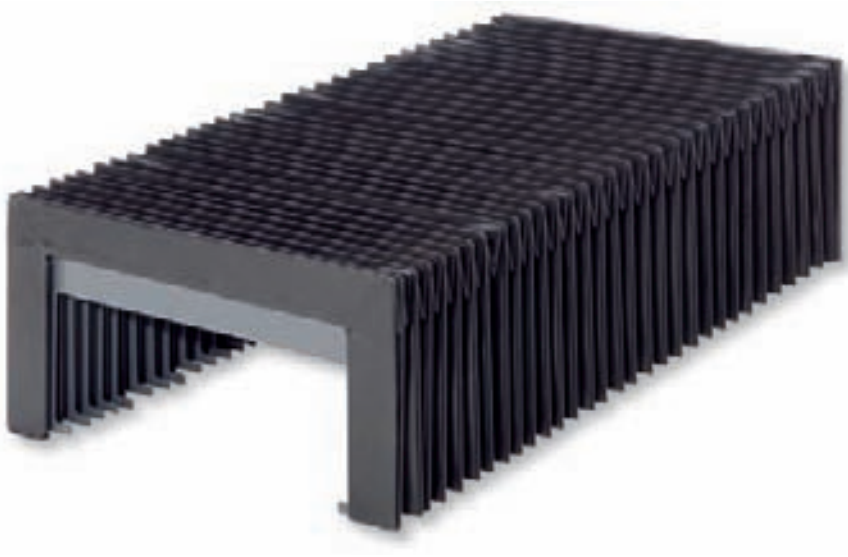

Properties

- Simple installation
- High travel speed
- Minimal compression
- High quality

Installation variants

- Horizontal, lying
- Horizontal, hanging
- Vertical

Delivery options

- For travel speeds of up to 1.5 m/s
- Customized production
- Available in a wide range of shapes
- Available in many different materials

Bellows

Guideway protection solutions with very little compression

Designs

U-bellows design

- Variable dimensions
- Customized in the guide
- Economically priced

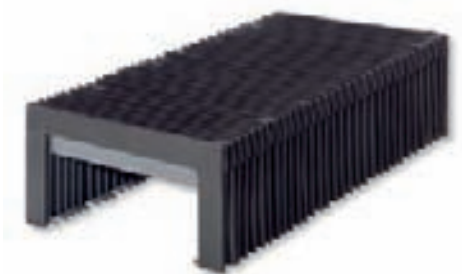

■ U-bellows design

Box bellows design

- Covering for movable machine elements
- High form stability



■ Box bellows design

U-bellows design with lamellas

- Reliable protection against heavy chip generation
- Rust-resistant and acid-resistant telescopic plates
- Can be made coolant-proof upon request
- Rigid or movable design of the telescopic plates is possible

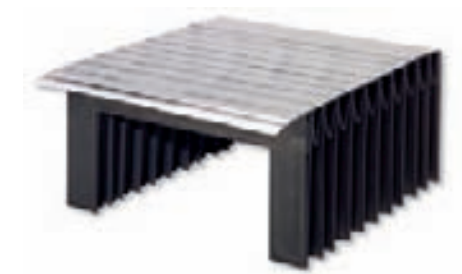

■ U-bellows design with lamellas

Additional shapes and designs are available on request.

Conical spring covers

Protection under extreme conditions

Conical spring covers protect spindles, columns, shafts, threads and rod guides reliably against contamination, chips and mechanical damage. They provide a good sealing function, and are self-cleaning if installed in a suitable position. High temperature resistance and resistance to chemicals guarantee reliable protection even under extreme operating conditions.



The springs are made of hardened high-quality spring band steel. The optimized design means that the horizontal bending and vertical deflection is very

low. Thus even in the extended state KABELSCHLEPP conical spring covers guarantee excellent protection against dirt and mechanical influences.

Properties

- Accident prevention for operating personnel from revolving spindles and shafts
- Reduction in downtimes resulting from contamination
- Increased machine service life
- Some conical spring covers are also available for retrofitting

Subject to change.

Conical spring covers



Selection

BASIC LINE

BASIC LINE PLUS

VARIO LINE

TUBE SERIES

3D LINE

STEEL LINE

Order

kabelschlepp.de

Fon: +49 2762 4003-0

LIFE-LINE Safety Cables
TOTALTRAX Complete Systems

Conveyor Systems

Enquiry forms – page 517

Guideway
Protection Systems



Conical spring covers

Protection under extreme conditions

Installation positions

The conically wound conical spring covers automatically follow the motions of the machine. Made of high-quality blue polished steel or alternatively of stainless steel, they can be used in vertical, horizontal and inclined positions.

Vertical installation

When installed vertically, conical spring covers are mounted with the larger diameter at the top. This way the overlapping of the individual coils makes the conical spring covers self-cleaning.



Horizontal installation

When installed horizontally, conical spring covers are mounted with the larger diameter in the direction of the chip generation. In horizontal installation with larger diameters or longer expansion, the maximum expansion is reduced to 60 % of the value for vertical installation.

Moreover, a slight sag appears in the conical spring cover, which is about 2 – 5 % of the maximum expansion.



Installation in inclined position

In addition to vertical and horizontal installation, installation in an inclined position is also possible. For small angles of incline above the horizontal the same conditions apply as in horizontal installation.





Installation of several conical spring covers in series

By connecting several conical spring covers in series it is possible to deal with special requirements, such as extra-long traversing distances.

We would be happy to advise you regarding such applications and can supply you with the necessary special flanges.



Retrofitting

Many conical spring covers are also available for retrofitting.

Selection

Selection of the conical spring cover suitable for your specific application is generally based on the following criteria:

- Internal diameter D1
- Expansion AZ (vertical / horizontal)
- Compression ZD

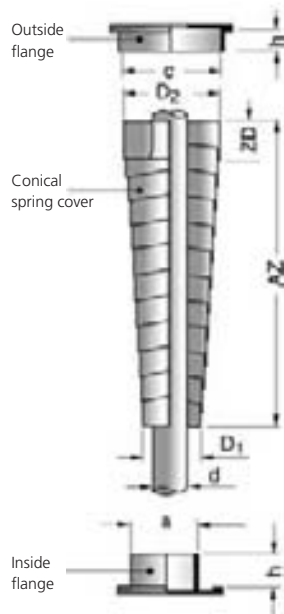

Roll-up covers

Protection in a minimum of space

KABELSCHLEPP roll-up covers serve to protect contact surfaces and guideways on all kinds of machine.

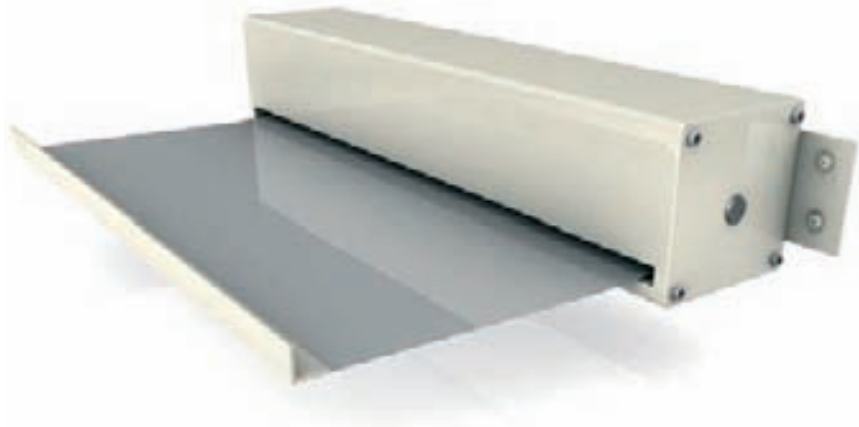

kabelschlepp.de

Properties

- For high travel speeds
- Minimal space required
- Customized production
- Simple installation
- Long service life
- Cost-effective

Designs

Roll-up cover without housing

Roll-up covers without a housing are suitable for areas with limited space, and facilitate optimal integration into the machine enclosure.



Roll-up cover with housing

Roll-up covers with an additional housing made of steel or aluminium protect the standard roll-up cover and allow simple installation or retrofitting.

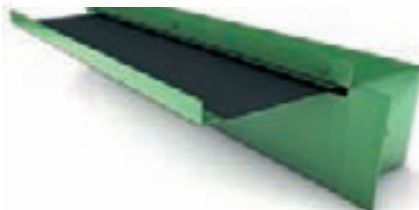

Fon: +49 2762 4003-0

Enquiry forms – page 518

Roll-up covers with plastic band

- Reliable protection against cutting waste, oil and cooling emulsions
- Particularly suitable for high travel speeds thanks to its low own weight
- Minimal space required
- Very resistant to tearing due to plastic layered special fabric
- Various materials are possible



Roll-up covers with steel band

- Very good protection against cutting waste, oil and cooling emulsions
- Rust-resistant and acid-resistant spring band steel with thickness from 0.2 to 0.4 mm
- Suitable for high travel speeds and greater mechanical loads
- Only available with housing

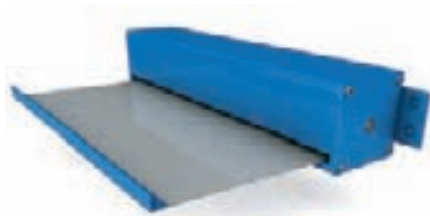

kabelschlepp.de

Fon: +49 2762 4003-0

Enquiry forms – page 518

Selection

BASIC
LINE

BASIC
LINEPLUS

VARIO
LINE

TUBE
SERIES

3D
LINE

STEEL
LINE

Order

LIFE-LINE Safety Cables
TOTALTRAX Complete Systems

Conveyor Systems

Guideway
Protection Systems



Protective devices

according to EN ISO 12100



PROTECT-PANEL

The "impenetrable" housing for your machines

page 496

PROTECT-PANEL system

The "impenetrable" housing for your machines

High speeds, quick machining cycles, cooling water and chips: Machine tools represent a dangerous environment for people. This is why all machine tools are contained in nearly "impenetrable" housings.

These help reduce or eliminate the hazards for the persons who work with them. With the KABELSCHLEPP PROTECT-PANEL system, we offer you optimized protection for a particularly attractive price.

Steel plate construction for a totally harmonised system

Every protective device is produced to your specifications – nevertheless made from standardized parts. We design in 3D and assemble your protective device from predefined elements. Special connecting elements hold the walls in line.

The entire system is made of steel. Extremely sturdy wall modules are created by using a combination of screws and rivets as well as sandwich-design without weld joints from industrially preassembled components. The wall elements are normally mounted vertically on C-profiles, e.g. on the shop floor. Unevenness of the floor surface can be compensated by adjusting hardware.

This production method offers you several advantages: Short design times by use of standardized parts. Short delivery times, since our production is based on predefined processes. Shorter installation time, since our mounting profiles are standardized and the wall elements are assembled with only a few screws. Processing on state-of-the-art processing machine tools provides a high precision for all elements. Avoiding welding as much as possible eliminates the potential for distortion and irregularities.

KABELSCHLEPP PROTECT-PANEL – modules:

- Wall modules
- Window modules
- Corner modules
- Roof modules
- Sliding doors
 - automatic design
 - telescopic design
- Folding doors
- Lift gates
- Roll gates
- Chip protection walls
- Powder coated
(colour as desired, RAL 9002 is standard)



PROTECT-PANEL: Secure protection against water spray

The unique connecting element means that the wall elements are sealed against water spray, and are joined to each other in an extra-sturdy manner. Each pair of modules is joined by specially-formed plates held together by bolts. An additional plate on the inside forms a labyrinth seal. In order to direct the remaining water spray downwards, we have fitted a deflector plate which guides the downward-flowing water directly into a particle conveyor, for example. The sandwich construction of the wall elements, together with the deflector plate, result in a sealed protective wall which can withstand even high water pressures.



- Protection against sprayed fluids:
Sealed with a rubber seal and deflector plate.

kabelschlepp.de

Fon: +49 2762 4003-0

Protective devices in modular design



PROTECT-PANEL – modules:



■ **Wall modules**
(standard dimensions
B x H 1235 x
2350 mm)



■ **Window modules**
(with special glass
pane insert)



■ **Corner modules**



■ **Roof modules**



■ **Sliding doors**
(automatic design)



■ **Sliding doors**
(telescopic design)



■ **Folding doors**
(electric motor-driven
under PLC control)



■ **Lift gates**
(up to six segments)



■ **Roll gates**
(vertical/vertical-
horizontal motion)



■ **Roll gates with stainless steel lamellas**
(opens quickly, lightweight design)

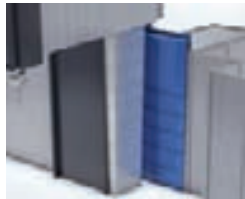

■ **Movable chip protection walls**
(vertical and horizontal)



PROTECT-PANEL system

The "impenetrable" housing for your machines

Protective devices in modular design

Wall modules

The standard wall module measurements are defined at 1235 mm width, 2350 mm height and 50 mm thickness. The sheet thickness of the outside cover plates is 2 mm.

Also the DIN EN 12415 and/or 17 standards are fulfilled by a total sheet thickness of 4 mm.

Using a 150 mm high floor-mounted C-profile with a wall connection element creates a grid spacing of 1250 x 2500 mm (W x H). The wall modules can be mounted side-by-side to form long walls. When necessary, supporting-columns are installed to add to lateral stability. Corner modules and roofs also provide a stabilizing effect and add to wall stability considerably. Connection elements have a labyrinth-seal on the work area side so that additional synthetic or rubber seals are not necessary. All parts of the walls are riveted or screwed together and are protected against rust by a powder coating in the desired colors. Cavity sealing protects the inner sides of the walls from condensation.



Windows modules

In the staging area of the machine polycarbonate-glass compound windows with high-grade steel frames are used which meet the DIN/EN 12415 standards for lathes and/or DIN/EN 12417 for machining centers. Outside the work area safety windows which are designated as single-pane safety glass are usually sufficient.

All window panes are installed in the walls – where necessary – in a splash-proof way. While the windows themselves are always produced as a rectangle, the opening can be formed according to customer preference. Whether oval, rectangular or rectangular with rounded corners, the organization of the external cover plates in the window area makes any shape possible.

Usual window measurements are 1000 x 1200 mm (W x H). The wall module in the standard measurements is made as a window module. If larger window widths are desired special modules are necessary.





kabelschlepp.de

Fon: +49 2762 4003-0

499

Corner modules

Wall modules can be combined to form corner modules. It is irrelevant whether it is a standard or a custom wall width. Specially designed corner profiles combine the elements at the header sides using screws and rivets imbedded in the already coated walls.

A metal valance reaching to the ground closes the outside corner opening and provides good aesthetics. As seen from the staging area the inside corner is sealed and waterproof without the use of synthetic seals. The 90° corner constructed in this way is extremely stable.

Multiple colors – as shown in the picture – require separately produced elements, since otherwise a powder coating would not be possible.



Roof modules

The machine tools had to be secured at the top for reasons of job safety.

The task: Although the covers to be constructed do not have to bear the same load as the side walls, they need to ensure a high degree of stability to effectively block flying chips.

Based on our PROTECT-PANEL system, we developed a roof with a sandwich design that is both light-weight and stable.

To dispense with inner braces, a bearing structure was selected that is also used for suspension bridges: Steel cables and pylons assume the static function for the roof elements.

Since workpieces are frequently supplied by cranes in processing centres, the roof was designed to open a few locations. This opening was created by two movable elements that telescopically overlap. The sliding roof elements take up very little space when open.



PROTECT-PANEL system

The "impenetrable" housing for your machines

Protective devices in modular design

Sliding doors (automatic design)

Because automatic doors are integrated into the machine tool programme, they automatically open and close according to the required production cycle. For heights of 2-3 m that's nothing special. But the automatic door in the PROTECT-PANEL system can manage much bigger sizes.

At the production plant of one of our customers, a first automatic door has been installed which is 6500 mm high, 1600 mm wide, 500 kg in weight and can open and close within 5 seconds. It's a challenge that we were able to solve with the help of linear drives, a three-phase motor and control shaft technology.



Sliding doors (telescopic design)

The access to the inside of machining centres is particular large due to our space-saving telescopic sliding door. Components in XXL format can be easily supplied.

The PROTECT-PANEL system already boasts of a series of sliding door and roll gate solutions. The telescopic sliding door can be opened wide quickly, but it remains impenetrable when closed.

The sliding door elements also come in a sandwich construction and additionally provided with bullet-proof glass window to allow a view of the interior.



Folding doors

To make exchanging workpieces easier, and if it is not possible to implement a guide rail in the upper and lower areas of the enclosure, then you can equip the enclosure with a folding door which moves to the side. The folding door is suspended only from a lateral post, leaving the greatest possible open space for your workpieces, especially in the upwards direction.

The door elements have the same design as the wall elements. Each of them is driven by a 24 V DC motor with a planetary gear unit and integrated PLC controller. Country-specific voltages can easily be obtained using an appropriate transformer.

Modern CAN-BUS technology makes it possible to program different motion patterns for individual door elements. Teaching and loading of programs are remarkably simple. If suitable CAN-BUS equipment is present, the motors can also be monitored using the machine controller. When closed, the



doors are held together by a locking mechanism, and will not open even if a person leans on them, for example. The end positions can be monitored and interrogated either via the program, or by means of additional limit switches.



kabelschlepp.de

Fon: +49 2762 4003-0

501

Lift gates

Unlike the roll gate, the lift gate has a small number of larger segments, which all move together. The segments have a sandwich construction, which makes them extremely resistant to penetration. These larger segments are thus not rolled up, but instead are positioned one behind the other, and hang neatly one behind the other when the door is open.

A special feature of this gate is its lifting and lowering mechanism, which makes use of pulleys. Each gate element is suspended on two pulleys, which raise or lower all of the elements evenly.



Roll gates

When changing pallets on machine tools, a gate is required that moves at high speeds when opening and closing. The PROTECT-PANEL roll gate functions in principle like a garage door. A segmented gate moves upwards and is rolled up. The height of an already built gate structure is 3500 mm.

The lamellas of this gate are made from aluminium, and are reinforced on the inside with steel inserts. This guarantees the required penetration resistance.

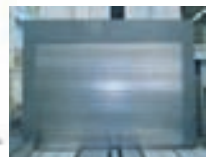

Roll gates with stainless steel lamellas

Different production processes require differentiated gate solutions. The roll gate with rugged stainless steel lamellas is an economical solution featuring lightweight construction.

Thanks to the special shaping of the lamellas the gates are very stable despite their low intrinsic weight and are very resistant to flying chips. The lightweight construction means that high speeds can be achieved when opening and closing.



Movable Chip protection walls

Machining tools should be kept ready near the machining area in order to ensure short distances and thus short changing times. To prevent damage and fouling of the tools that are kept ready, they have to be given special protection.

Our chip protection wall separates the machining cell from the tool magazine and protects the tools in the magazine that are not needed for the current machining operation.

It can be traversed horizontally for loading; during machining it follows the vertical motion of the cross beam.



Hinged belt conveyors question form.

Purpose of the conveyor: _____

Material to be conveyed: _____

Type of material to be conveyed (for chips: type of chip): _____

Max. dimensions of material to be conveyed: _____

Material: _____

Output: _____ m³/h _____ kg/h

Coolant:

Type of coolant: Emulsion Oil _____

Quantity of coolant: _____ l/min

Coolant container: On conveyor housing

Separate container

With pump

With float bracket

Electrical connection values:

Operating voltage: _____ volts

Control voltage: _____ volts

Frequency: _____ Hz

Electrical control

Supplied by KARELSCHLEPP GmbH

Material to be provided by customer

Design of control _____

Overload safety

Electrical overload protection (e.g. motor protection switch)

Current monitoring relay

Torque switching via limit switch
(only when conveyor driven by attachable gear motor)

Paintwork

Primer _____

Paint = RAL _____

Design

Straight

Straight/rising

Straight/rising/straight



■ Straight design
Horizontal or rising
Max. incline 45°













■ Straight/rising design
Max. incline 45°



■ Straight/rising/straight design
Max. incline 60°

Enquiry forms

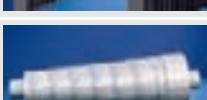
Question forms and technical information

	Hinged belt conveyors Question form	page 504
	Scraper conveyors Question form	page 506
	Modular conveyors Question form	page 508
	Belt conveyors Question form	page 509
	Telescopic covers Question form	page 510
	Telescopic covers Technical information question form	page 511
	Way wipers Question form	page 514
	Link apron covers Question form	page 515
	Bellows Question form	page 516
	Conical spring covers Question form	page 517
	Roll-up covers Question form	page 518

Hinged belt conveyors question form

Purpose of the conveyor: _____

Material to be conveyed:

Type of material to be conveyed (for chips: type of chip): _____

Max. dimensions of material to be conveyed: _____

Material: _____

Output: _____ m³/h _____ kg/h

Coolant:

Type of coolant: Emulsion Oil _____

Quantity of coolant: _____ l/min

Coolant container: On conveyor housing
 Separate container
 With pump
 With float bracket

Electrical connection values:

Operating voltage: _____ volts

Control voltage: _____ volts

Frequency: _____ Hz

Electrical control

Supplied by KABELSCHLEPP GmbH
 Material to be provided by customer

Design of control _____

Overload safety

Electrical overload protection (e.g. motor protection switch)
 Current monitoring relay
 Torque switching via limit switch
 (only when conveyor driven by attachable gear motor)

Varnish coating

Primer _____

Paint – RAL _____

(if not otherwise specified, RAL 7035 – light-grey – will be delivered)

Design

Straight
 Straight/rising
 Straight/rising/straight



■ **Straight design**
Horizontal or rising.
Max. incline 45°



■ **Straight/rising design**
Max. incline 45°



■ **Straight/rising/straight design**
Max. incline 60°



Straight design

Construction dimensions:

Overall length L_G : _____ mm

Box height H_K : 140 mm (SRF 040.00)
 216 mm (SRF 063.00)
 360 mm (SRF 100.00)

Box width B_K : _____ mm

Belt width B_{SCH} : _____ mm

Panel height H_B : _____ mm

Additional information

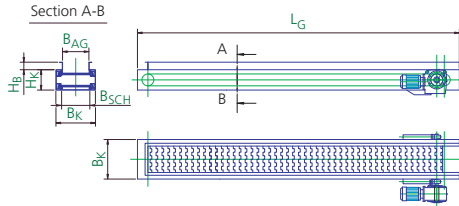

Straight/rising design

Construction dimensions:

Overall length L_G : _____ mm

Feed length L_{AG} : _____ mm

Distance between axles, vertical A_{AV} : _____ mm

Box height H_K : 140 mm (SRF 040.00)
 216 mm (SRF 063.00)
 360 mm (SRF 100.00)

Box width B_K : _____ mm

Belt width B_{SCH} : _____ mm

Panel height H_B : _____ mm

α : _____ mm

Additional information

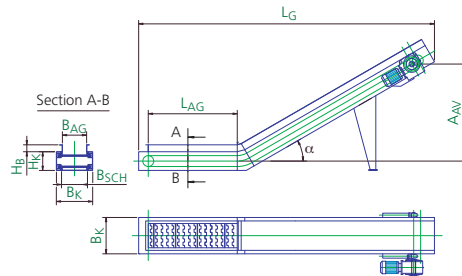

Straight/rising/straight design

Construction dimensions:

Overall length L_G : _____ mm

Feed length L_{AG} : _____ mm

Distance between axles, vertical A_{AV} : _____ mm

Box height H_K : 140 mm (SRF 040.00)
 216 mm (SRF 063.00)
 360 mm (SRF 100.00)

Box width B_K : _____ mm

Belt width B_{SCH} : _____ mm

Panel height H_B : _____ mm

α : _____ mm

Discharge length L_{AW} : _____ mm

Additional information

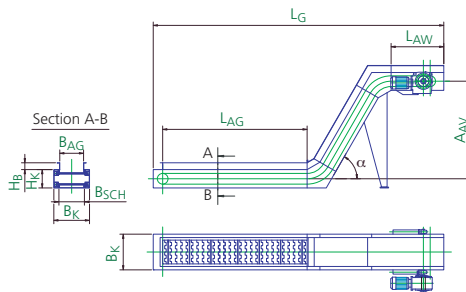



Scraper conveyors question form

Purpose of the conveyor: _____

Material to be conveyed:

Type of material to be conveyed (for chips: type of chip): _____

Max. dimensions of material to be conveyed: _____

Material: _____

Output: _____ m³/h _____ kg/h

Coolant:

Type of coolant: Emulsion Oil _____

Quantity of coolant: _____ l/min

Coolant container: On conveyor housing
 Separate container
 With pump
 With float bracket

Electrical connection values:

Operating voltage: _____ volts

Control voltage: _____ volts

Frequency: _____ Hz

Electrical control

Supplied by KABELSCHLEPP GmbH
 Material to be provided by customer

Design of control _____

Overload safety

Electrical overload protection (e.g. motor protection switch)
 Current monitoring relay
 Torque switching via limit switch
 (only when conveyor driven by attachable gear motor)

Varnish coating

Primer _____

Paint – RAL _____

(if not otherwise specified, RAL 7035 – light-grey – will be delivered)

Design

Straight
 Straight/rising
 Straight/rising/straight



■ **Straight design**
Horizontal or rising.
Max. incline 45°



■ **Straight/rising design**
Max. incline 45°



■ **Straight/rising/straight design**
Max. incline 60°



Straight design

Construction dimensions:

Overall length L_G : _____ mm
 Box height H_K : 140 mm (KRF 040.00)
 216 mm (KRF 063.00)
 360 mm (KRF 100.00)

Box width B_K : _____ mm
 Belt width B_{KR} : _____ mm

Additional information

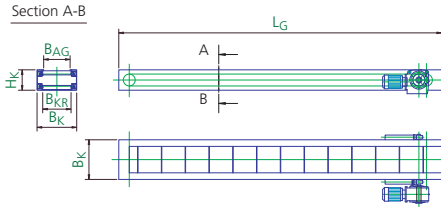

Straight/rising design

Construction dimensions:

Overall length L_G : _____ mm
 Feed length L_{AG} : _____ mm
 Distance between axles, vertical A_{AV} : _____ mm
 Box height H_K : 140 mm (KRF 040.00)
 216 mm (KRF 063.00)
 360 mm (KRF 100.00)

Box width B_K : _____ mm
 Belt width B_{KR} : _____ mm
 α : _____ mm

Additional information

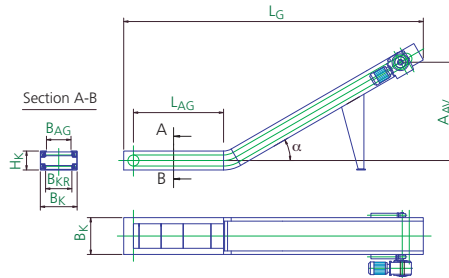

Straight/rising/straight design

Construction dimensions:

Overall length L_G : _____ mm
 Feed length L_{AG} : _____ mm
 Distance between axles, vertical A_{AV} : _____ mm
 Box height H_K : 140 mm (KRF 040.00)
 216 mm (KRF 063.00)
 360 mm (KRF 100.00)

Box width B_K : _____ mm
 Belt width B_{KR} : _____ mm
 α : _____ mm
 Discharge length L_{AW} : _____ mm

Additional information

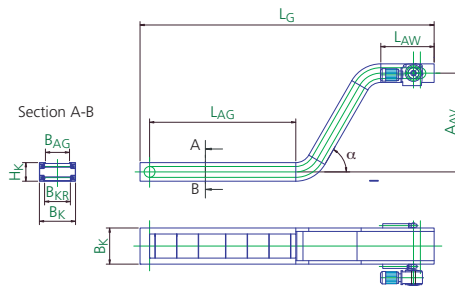

Modular conveyors question form

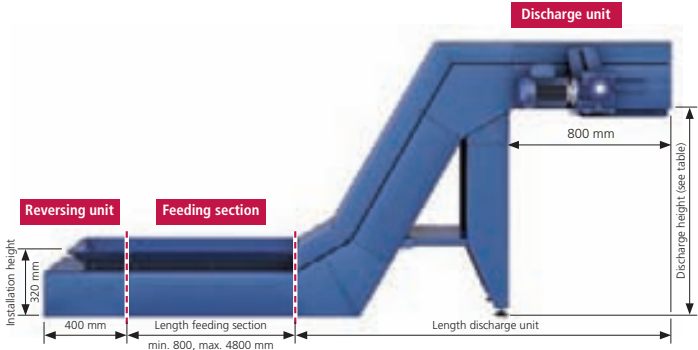

Section A-B

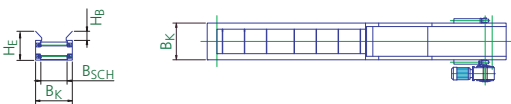

Discharge unit

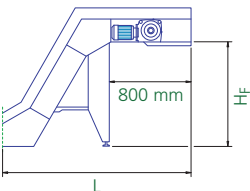

Discharge unit modul	Choice
Discharge unit 800	
Discharge unit 1200	
Discharge unit 1600	

Feeding section

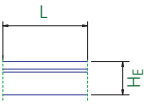

Feeding section modul	Quantity
Feeding section 800	
Feeding section 1200	
Feeding section 1600	

Total length feeding section _____ (mm)

Reversing unit

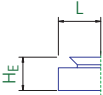

Reversing unit modul	Choice
Reversing unit	<input checked="" type="radio"/>

Standard subassembly	Discharge height H _F	Belt width B _{SCH}	Box width, B _K	Panel height H _B	Length L	Installation height H _E
Discharge unit 800	1115	300	420	80	1845	–
Discharge unit 1200	1460	300	420	80	2045	–
Discharge unit 1600	1810	300	420	80	2245	–
Feeding section 800	–	300	420	80	800	320
Feeding section 1200	–	300	420	80	1200	320
Feeding section 1600	–	300	420	80	1600	320
Reversing unit	–	300	420	80	400	320

Belt conveyors question form

Purpose of the conveyor: _____

Material to be conveyed:

Type of material to be conveyed (for chips: type of chip): _____

Max. dimensions of material to be conveyed: _____

Material: _____

Output: _____ m³/h _____ kg/h

Electrical connection values:

Operating voltage: _____ volts

Control voltage: _____ volts

Frequency: _____ Hz

Electrical control

Supplied by KABELSCHLEPP GmbH

Material to be provided by customer

Design of control _____

Overload safety

Electrical overload protection (e.g. motor protection switch)

Current monitoring relay

Varnish coating

Primer _____

Paint – RAL _____

(if not otherwise specified, RAL 7035 – light-grey – will be delivered)

Construction dimensions:

Conveying length FL: _____ mm

Discharge height AH: _____ mm

Belt width GB: _____ mm

Additional information



■ **Standard design**
Horizontal or rising.
Max. incline 30°

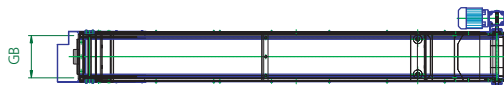
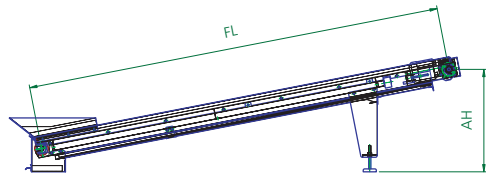

Telescopic covers question form

Machine data:

Machine type: _____

Use of telescopic cover:

- Machine base
 Standing
 Cross-beam

Machine travel (travel distance LS_k) _____ mm

Travel speed v : _____ m/min

Acceleration a : _____ m/s^2

Width of guideway B_g : _____ mm

Guideway lubrication:

- Hydrostatic
 Aerostatic
 Other _____



Photograph: Waldrich Siegen Werkzeugmaschinen GmbH

Data for the design of the telescopic cover:

Travel length of telescopic cover LS : _____ mm

Maximum compression of telescopic cover L_z : _____ mm

Possible width of the telescopic cover B_A : _____ mm

Possible height of the telescopic cover above the guideway $H_{1,x}$: _____ mm

Possible total height of telescopic cover H_G : _____ mm

Connection of telescopic cover: _____

Wiper with protective strip for protection against hot chips: yes no

Additional information:

Interference contours around the telescopic cover (way wipers, lines, etc.):

Design of the telescopic cover: Not walkable-on Walkable-on when at rest

Quantity of chips: _____ kg/h

Type of chips: _____

Coolant:

Type: _____

Quantity: _____ l/min

Can consoles be attached? yes no

Should consoles be attached? yes no

Other information

Horizontally-installed telescopic covers

Technical information

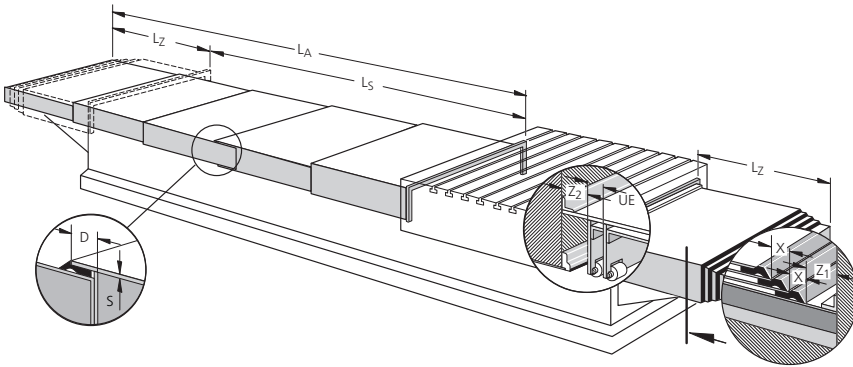

Explanation of terms Technical explanations

- B_A = Maximum width of the telescopic cover
- B_B = Width of guideway
- B_{U1} = Width of undergrip – left
- B_{U2} = Width of undergrip – right
- h_1 = Thickness of upper bundle of plates
- h_2 = Thickness of side bundle
- h_3 = Thickness of undergrip bundle
- $H_{1,1}$ = Height of telescopic cover above the contact surface – left
- $H_{1,2}$ = Height of telescopic cover above the contact surface – right
- $H_{2,1}$ = Height of side leg piece – left
- $H_{2,2}$ = Height of side leg piece – right
- H_G = Total height of telescopic cover
- Z_1 = Console plate extension
- Z_2 = Support plate extension
- v = Travel speed
- L_{SK} = Machine travel length

The travel length of the machine is the distance that a moving machine component travels from one end position to the other.

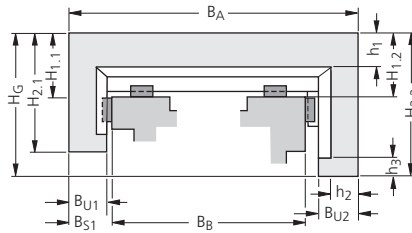

- L_S = Travel length of telescopic cover

$$L_S = L_{SK} + \text{reserve}$$

- L_Z = Compression

If the individual sheet metal elements are compressed in an end position, then the compression is the length of the bundle of metal plates.

- n = Number of plates
- s = Plate thickness
- D = Sheathing (non-expandable plate length)
- UE = Distance between the plates at the support
- X = Gradation of metal plate at the driver wipe
- l = Plate length

The relationship between the plate length and plate width is selectable up to a ratio of 1:8.

Vertically-installed telescopic covers

Technical information

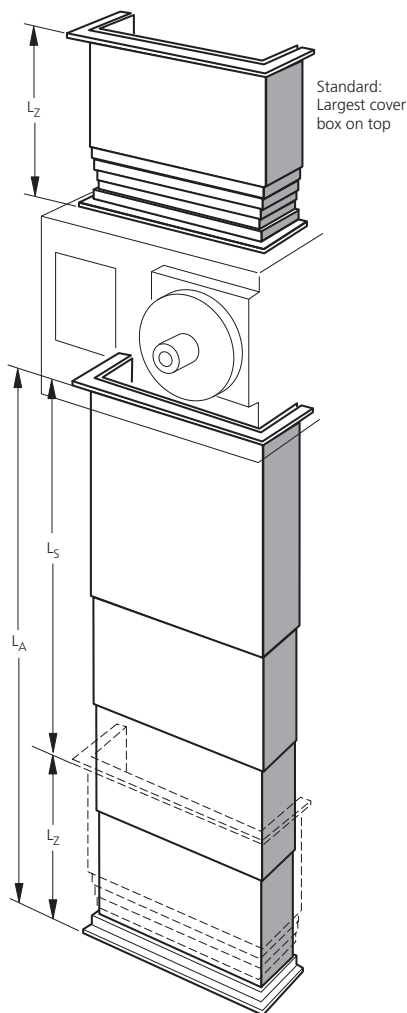

Explanation of terms Technical explanations

B_A = Maximum width of the telescopic cover

B_B = Width of guideway

B_{U1} = Width of undergrip – left

B_{U2} = Width of undergrip – right

h_1 = Thickness of upper bundle of plates

h_2 = Thickness of side bundle

h_3 = Thickness of undergrip bundle

a = Angle at undergrip

$H_{1.1}$ = Height of telescopic cover above the contact surface – left

$H_{1.2}$ = Height of telescopic cover above the contact surface – right

$H_{2.1}$ = Height of side leg piece – left

$H_{2.2}$ = Height of side leg piece – right

H_G = Total height of telescopic cover

v = Travel speed

L_{SK} = Machine travel length

The travel length of the machine is the distance that a moving machine component travels from one end position to the other.

L_S = Travel length of telescopic cover

$$L_S = L_{SK} + \text{reserve}$$

L_Z = Compression

If the individual sheet metal elements are compressed in an end position, then the compression is the length of the bundle of metal plates.

n = Number of plates

s = Plate thickness

D = Sheathing (non-expandable plate length)

UE = Distance between the plates at the support

X = Gradation of metal plate at the driver wiper

l = Plate length

The relationship between the plate length and plate width is selectable up to a ratio of 1:8.

Horizontal, hanging telescopic covers

Technical information

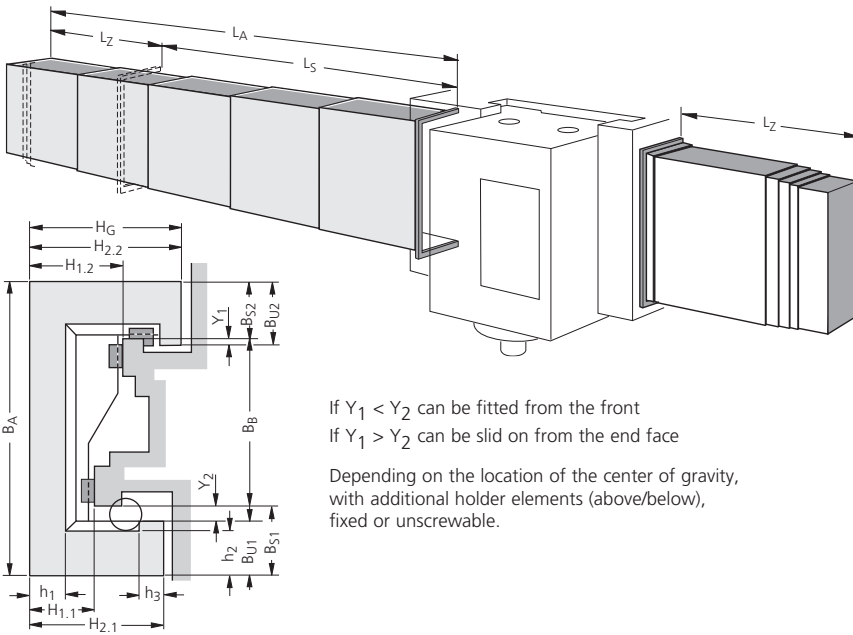

If $Y_1 < Y_2$ can be fitted from the front
If $Y_1 > Y_2$ can be slid on from the end face

Depending on the location of the center of gravity,
with additional holder elements (above/below),
fixed or unscrewable.

Explanation of terms Technical explanations

- B_A = Maximum width of the telescopic cover
- B_B = Width of guideway
- B_{U1} = Width of undergrip – left
- B_{U2} = Width of undergrip – right
- h_1 = Thickness of upper bundle of plates
- h_2 = Thickness of side bundle
- h_3 = Thickness of undergrip bundle
- $H_{1.1}$ = Height of telescopic cover above the contact surface – left
- $H_{1.2}$ = Height of telescopic cover above the contact surface – right
- $H_{2.1}$ = Height of side leg piece – left
- $H_{2.2}$ = Height of side leg piece – right
- H_G = Total height of telescopic cover
- v = Travel speed
- L_{SK} = Machine travel length

- L_S = Travel length of telescopic cover

$$L_S = L_{SK} + \text{reserve}$$

- L_Z = Compression

If the individual sheet metal elements are compressed in an end position, then the compression is the length of the bundle of metal plates.

- n = Number of plates
- s = Plate thickness
- D = Sheathing (non-expandable plate length)
- UE = Distance between the plates at the support
- X = Gradation of metal plate at the driver wiper
- l = Plate length

The relationship between the plate length and plate width is selectable up to a ratio of 1:8.



Way wipers question form

Standard design:

Type	Standard length	Quantity
Type BA 18	1000 mm	_____
Type BA 25	1000 mm	_____
Type BAS 18	1000 mm	_____
Type BAS 25	1000 mm	_____
Type BAS 40	1000 mm	_____
Type BA 65-14	500 mm	_____
Type BA 65-18	500 mm	_____
Type BA 65-25	500 mm	_____
Type BA 115-30	500 mm	_____
BAY-WIPE	516 mm	_____

Harnessed wipers:

Drawing/sketch of the wiper with precise dimensioning

Pre-wiper for protecting the wiper lip against hot chips:

yes no

Environmental conditions (temperature, coolant, dirt, etc.):



Link apron covers question form

Travel speed: _____ m/min

Length: _____ mm

Width: _____ mm

Designs:

Design 1

$B_{min} = 100 \text{ mm}$

$B_{max} = 950 \text{ mm}$

$R_{min} = 25 \text{ mm}$

Weight = 5.6 kg/m²

Solid aluminium profile 19 x 3.0 mm
with PU connecting elements



■ Design 1



Design 2

$B_{min} = 100 \text{ mm}$

$B_{max} = 2950 \text{ mm}$

$R_{min} = 50 \text{ mm}$

Weight = 14.2 kg/m²

Solid aluminium profile 20 x 5.5 mm
with PU connecting elements

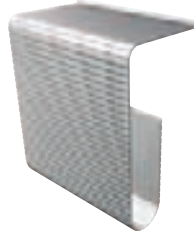

■ Design 2



Design 2N

$B_{min} = 100 \text{ mm}$

$B_{max} = 2950 \text{ mm}$

$R_{min} = 50 \text{ mm}$

Weight = 10 kg/m²

Hollow aluminium profile 20 x 5.5 mm
with PU connecting elements



■ Design 2N



Design 3

$B_{min} = 100 \text{ mm}$

$B_{max} = 2000 \text{ mm}$

$R_{min} = 60 \text{ mm}$

Weight = 16.5 kg/m²

Hollow aluminium profile 18.5 x 6.8 mm
without PU connecting elements



■ Design 3



End attachment:

Comments:





Bellows question form

Drawing/sketch of the cross-section to be covered

Travel speed: _____ m/min

Total expansion: _____ mm

Compression: _____ mm

Machine travel: _____ mm

Max. external dimensions: _____ mm

End attachment:

Installation position:

Environmental conditions (temperature, etc.):

Use of emulsions (type and quantity in l/min):

Annual requirements:

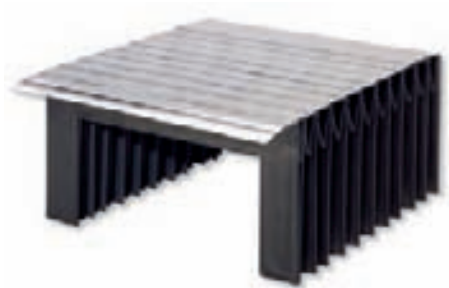



Conical spring covers question form

Internal diameter: _____ mm
 Travel speed: _____ m/min
 Total expansion: _____ mm
 Compression: _____ mm
 Machine travel: _____ mm
 Max. external dimensions: _____ mm



Material:

- Spring band steel, blue polished
- Stainless steel

Installation position:

Environmental conditions (temperature, etc.):

Use of emulsions (type and quantity in l/min):

Annual requirements:

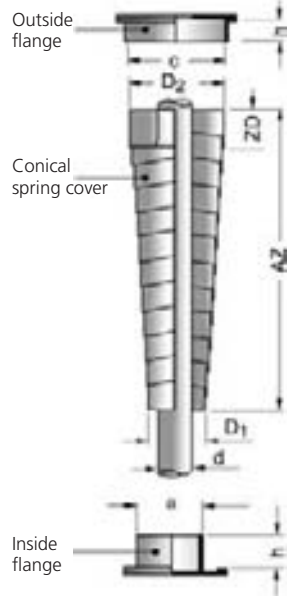

Type designation

025 – 0100 – 020 V 0

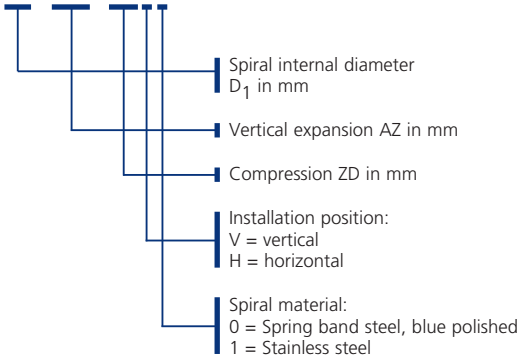

Conical spring cover

- d = Shaft/spindle diameter
- a = Diameter of the guide sleeve
- c = Hole diameter in the external flange
- a ≤ D₁ – 4 mm
- D₁ = Spiral internal diameter
- D₂ = Spiral external diameter
- c = External diameter of the internal flange
- Internal diameter of the external flange
- c ≥ D₂ + 6 mm
- h = Flange height
- (0.6 x ZD ≤ h ≤ (ZD – 2 mm))
- ZD = Compression
- AZ = Expansion / expansion length

The guide flange is not included in the scope of supply, but can be supplied at the same time on request.

When ordering please indicate the installation position and spiral material. See "Type designation".

Roll-up covers question form

Travel speed: _____ m/min

Total expansion: _____ mm

Machine travel: _____ mm

Belt width: _____ mm

End attachment:

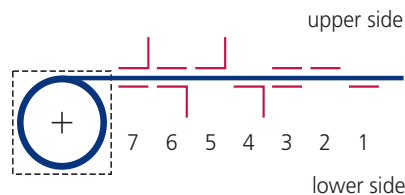

1 2 3 4 5 6 7

Installation position:

Design:

- With housing
 Without housing

Belt type:

- Stainless steel
 Plastic

Environmental conditions (temperature, emulsions, etc.):

Annual requirements:



Notes

Lined area for notes

Subject to change.

Fon: +49 2762 4003-0

kabelschlepp.de

Protective Devices

Guideway Protection Systems

Conveyor Systems

LIFE-LINE Safety Cables
TOTALTRAX Complete Systems

Order

STEEL LINE

3D LINE

TUBE SERIES

VARIO LINE

BASIC LINEPLUS

BASIC LINE

Selection

KABELSCHLEPP is there for you:

Around the world

Germany

Headquarter

KABELSCHLEPP GmbH
Daimlerstraße 2
57482 Wenden-Gerlingen
Fon: +49-2762/4003-0
Fax: +49-2762/4003-220
info@kabelschlepp.de

Service-Center

KABELSCHLEPP GMBH-
HÜNSBORN
Wielandstraße 1 -
Industriegebiet Ost
57482 Wenden-Hünsborn
Fon: +49-2762/97420
Fax: +49-2762/974299
ksh@kabelschlepp.de

Automotive

KABELTRAX Europe GmbH –
Automotive
Daimlerstraße 2
57482 Wenden-Gerlingen
Fon: +49-2762/4003-300
Fax: +49-2762/4003-40300
info@kabeltrax.de
www.kabeltrax.de

KABELSCHLEPP international

America

KABELSCHLEPP AMERICA
7100 West Marcia Road
Milwaukee, WI 53223-3363
Fon: +14143541994
Fax: +14143541900
info@kabelschlepp.com
www.kabelschlepp.com

KABELTRAX LLC – Automotive

7100 West Marcia Road
Milwaukee, WI 53223-3363
Fon: +14143541994
Fax: +14143541900
info@kabeltrax.com
www.kabeltrax.com

Argentina

NORTECNICA S.R.L.
103 Heredia 638
1672 Villa Lynch - Pica
Pcia. De Buenos Aires
Fon: +54-11/47573129
Fax: +54-11/47571088
info@nortecnica.com.ar

Australia

Conductix-Wampfler
14 England Street
Dandenong Vic 3175
Fon: +61-3/9706-8844
Fax: +61-3/9794-9298
sales-australia@conductix.com
www.conductix.com.au

Austria

Robert Ganglberger
Holzbauernstraße 20
4050 Traun
Fon: +43-7229/74330
Fax: +43-7229/61503
ganglberger.r@aon.at
www.kabelschlepp.at

Belgium

Wisman Techniek BVBA
Drie Eikenstraat 112
2650 Edegem
Fon: +32-3/4572482
Fax: +32-3/4572980
electro@wisman-techniek.be
www.wisman-techniek.be

Brazil

Porta Cabos Indústria e
Comércio Ltda.
R. Francisco Visentainer, 875 –
09861 639
V. Santa Cássia
São Bernardo do Campo – S.
Paulo
Fon: +55-11-4072-1217
Fax: +55-11-4072-1223
portacabos@portacabos.com.br
www.portacabos.com.br

China

Kabelschlepp (China) Co. Ltd.
Plant No. 2 of Germany Industry
Park
Zhangpu Town, 215321
Kunshan City
Fon: +86-512/57293500
Fax: +86-512/57296400
kabelschlepp@
kabelschlepp.com.cn

TSUBAKI KABELSCHLEPP
SHANGHAI CO., LTD.
Rm. 701, Tomson Financial
Building,
No. 710 Dong Fang Rd.,
Pudong Shanghai, P.R.C.
200122
Fon: +86-21/68760511
Fax: +86-21/68769456
zhangtks@sh163.net

Czech Republic

OPTICONTROL s.r.o.
Lelekovice 103
66431 Brno
Fon: +420-5/41232289
Fax: +420-5/41232711
info@opticontrol.cz
www.kabelschlepp.cz

Denmark

Bagger-Nielsen
Svalehøjvej 10
3650 Ølstykke
Fon: +45-7020/7633
Fax: +45-7020/7603
info@bagger-nielsen.dk
www.bagger-nielsen.dk

Finland

Movetec Oy
Hannuksentie 1
02270 Espoo
Fon: +358-9/5259230
Fax: +358-9/52592333
info@movetec.fi
www.movetec.fi

France

KABELSCHLEPP FRANCE
S.A.R.L.
27, Rue du chemin vert
B.P. 1 Bâtiment Pariwest
78612 Le Perray en Yvelines
Fon: +33-1/34846365
Fax: +33-1/34848671
contact@kabelschlepp.fr
www.kabelschlepp.fr

Great Britain

KABELSCHLEPP METOOL
Metool Products Ltd.
Unit 1, Mercian Park
Mercian Close, Manners
Industrial Estate
Ilkeston, Derbyshire DE7 8HG
Fon: +44-115/9225931
Fax: +44-115/9258183
postmaster@metool.com
www.kabelschlepp.co.uk

Greece

E. D. Koumakis S.A.
O.T. 32 Sindos Industrial Area
P.O.B. 199
57022 Thessaloniki - Hellas
Fon: +30-23 10/796791
Fax: +30-23 10/795056
info@koumakis.gr
www.koumakis.gr



Hungary

FIGRA -
Műszaki Kereskedelmi Kft
Szentmiklósi út 14.
1213 Budapest
Fon: +36-1/420-3053
Fon/Fax: +36-1/277-6067
figra@t-online.hu
www.figra.hu

India

Kabelschlepp India Pvt. Ltd.
B-14, ITI Ancillary Industrial
Estate
Mahadevapura Post,
Bangalore - 560048
Fon: +91-80-41158997
Fon: +91-80-41158998
sales@kabelschlepp.info

Israel

RS Tech Ltd
64 Ashkenazy St.
Tel-Aviv 69869
Fon: +972-3-649 0454
Fon: +972-3-64873 07
samital@012.net.il

Italia

KABELSCHLEPP ITALIA S.R.L.
Via Massari Marzoli, 9
21052 Busto Arsizio - VA
Fon: +39-0331/350962
Fax: +39-0331/341996
infoksi@kabelschlepp.it
www.kabelschlepp.it

Japan

TSUBAKIMOTO CHAIN
COMPANY
1-3, Kannabidai 1 Cho-me
Kyotanabe
Kyoto 610-0380
Fon: +81-774-64-5212
Fax: +81-774-64-5024
takayuki.matsuda@
gr.tsubakimoto.co.jp
www.tsubakimoto.co.jp

Korea

KABELSCHLEPP Korea Inc.
SK TechnoPark B/D Tech-1312,
190-1, SangDaeWon-Dong,
JungWon-Gu,
SeongNam-City, GyeongGi-Do,
South Korea (465-120)
Fon: +82-31-776-4420
Fax: +82-31-776-4424
sale@kskorea.kr

Liechtenstein

see Switzerland

Luxembourg

Wisman Technik BVBA
Drie Eikenstraat 112
2650 Edegem
Fon: +32-3/4572482
Fax: +32-3/4572980
electro@wisman-technik.be
www.wisman-technik.be

Netherlands

Wisman Electrotechniek
De Vente 10
7261 ST Ruurlo
Fon: +31-88/0023500
Fon: +31-88/0023599
electro@wisman-technik.nl
www.wisman-technik.nl

Norway

Ing. H. Asmyhr a.s.
Hvamsvingen 10
2013 Skjetten
Fon: +47-64/834550
Fax: +47-64/834555
firmapost@asmyhr.no
www.asmyhr.no

Poland

KABELSCHLEPP Sp z o.o. Polen
ul. Piekna 13
85303 Bydgoszcz
Fon: +48-52/34877 11
Fax: +48-52/34877 15
kabelschlepp@kabelschlepp.com.pl
www.kabelschlepp.com.pl

Portugal

Vahle Portuguesa
Sistemas de Alimentação
Eléctrica, Lda.
Quinta do Borel,
Rua Tenente Gouveia, 21-21^a
2720-525 Amadora
Fon: +351 214998690
Fax: +351 214998699
geral@vahle.pt
www.vahle.pt

Russia

see White Russia

Singapore

KABELSCHLEPP Singapore
Pte. Ltd.
60 Kaki Bukit Place
#07-15 Eunos Techpark
Singapore 415979
Fon: +65-68419008
Fax: +65-68416887
sales@kabelschlepp.com.sg

Slovakia

KABELSCHLEPP SYSTEMTECHNIK
spol. s r.o.
Povazská 67
94067 Nové Zámky
Fon: +421-35/6923200
Fax: +421-35/6923222
info@kabelschlepp.sk
www.kabelschlepp.sk

Slovenia

Inoteh d.o.o.
K Zelenici 77
2345 Bistrica ob Dravi / Slovenia
Fon: +386-2/66511 31
Fax: +386-2/6652081
info@inoteh.si
www.inoteh.si

South Africa

MAGQUIP PTY LTD
P.O.Box 682
Maraisburg 1700.
Fon: +27-11/4727 109
Fax: +27-11/4725 535
info@magquip.co.za

Spain

Exclusivas Rein, S.A.
Portal de Gamarra, 36
Pabellón 14
01013 Vitoria
Fon: +34-945/262922
Fax: +34-945/266437
tecnico@exrein.es
www.exrein.es

Sweden

Miltronic AB
Kungshagsvägen 7
P.O. Box 1022
61129 Nyköping
Fon: +46-1557 77 00
Fax: +46-1557 77 01
info@miltronic.se
www.miltronic.se

Switzerland/Liechtenstein

Hans Hess & Co. AG
Gewerbestrasse 16/Postfach
8800 Thalwil
Fon: +41-44/7225500
Fax: +41-44/7225502
mail@hanshess.ch
www.hanshess.ch

Taiwan

SIGNET TRADING CO. LTD.
No. 99, An-Chai 8th St.
Hsin-Chu Industrial Park.
Hu-Ko, Hsin-Chu
Fon: +886-35/978808
Fax: +886-35/978848
gudel@ms44.hinet.net
signet@tps4.seed.net.tw

Thailand

PLANET T & S CO., LTD
42 Seree 4 Road, Suanluang
Suanluang, Bangkok
Fon: +662 7189935-7
Fax: +662 7203343
info@planet.co.th
www.planet.co.th

Turkey

Kabellimited
Kabel Enerji iletim zincirleri
San. Tic. Ltd. Sti.
Nilüfer Ticaret merkezi 61. Sk.
No: 17
16120 Nilüfer-Bursa
Fon: +90-224/4440075
Fax: +90-224/4417230
kabel@kabeltr.com
www.kabeltr.com

Ukraine

see White Russia

Venezuela

NORSTAD C.A.
Apdo. 68761
Caracas 1062 A
Fon: +58/2 1242 5358
Fax: +58/2 1241 6848

White Russia/Russia

Asboga LTD
Minsk region
Smolevichski ar. Vill.
Zadomlya 41a
222210 Minsk / Belarus
Fon: +375-17285-64-67
+375-17280-2486
Fax: +375-17287-3727
ks@asboga.ru



The power to innovate



IDEAS AROUND THE MACHINE

CABLE CARRIER SYSTEMS

Cable carriers made of steel and plastic
QUANTUM cable and hose carrier system
PROTUM cable and hose carrier system
PROFILE cable and hose carrier system
ROBOTRAX cable and hose carrier system

LIFE-LINE Safety Cables

Continuous bending hi-flex cables for cable carriers
TOTALTRAX complete turn-key carrier systems
Pre-assembled cables

GUIDEWAY PROTECTION SYSTEMS

Telescopic covers
Link apron covers
Way wipers
Conical spring covers
Bellows
Protective devices

CONVEYOR SYSTEMS

Hinged belt conveyors
Scraper conveyors
Belt conveyors

KABELSCHLEPP GmbH

Daimlerstraße 2
D-57482 Wenden-Gerlingen
Fon: +49 2762 4003-0
Fax: +49 2762 4003-220
E-mail: info@kabelschlepp.de
kabelschlepp.de

KABELSCHLEPP worldwide

For contacts, addresses and
much more, visit our web site at
kabelschlepp.de