

53105300	DATA SHEET	
Valid from: 30.09.2024	SKINTOP® HYGIENIC SC	

The SKINTOP® HYGIENIC SC is a high-quality cable gland that is suitable for hygienic critical areas. The innovative hygienic design prevents food machines, facilities, or components from risk of contamination. The cable gland is suitable for use in applications where mechanical and chemical stability to very aggressive media is required and offers quality and safety in food, pharmaceutical and chemical industry.

The SKINTOP® HYGIENIC SC is especially designed for copper-screened cables to achieve a low-resistance screen contact, strain relief and high protection class.



Components:

Gland body	Stainless steel – V4A (1.4404 / 316L)
Cap nut	Stainless steel – V4A (1.4404 / 316L)
Insert with lamellar cage	Polyamide
Contact spring	CuBe, tin-plated
Seals	Special elastomer – conform to FDA 21 CFR 177.2600

Technical features:

Connecting thread	M12x1,5 up to M40x1,5 acc. to EN 60423
Protection class	IP68 – 10 bar, test acc. to EN 60529 IP69 acc. to EN 60529
NEMA Type Rating	NEMA Type 1, Type 2, Type 4X, Type 6, Type 12 acc. to UL50E
Strain relief	Category A
Transfer impedance	< 0,1 Ohm
Temperature range	-20 °C up to +100 °C

Other properties:

- High functional safety
- Optimal strain relief
- Wide and variable clamping range
- Hygienic design
- Product zone (food)

Approbations:



UL File Nr. 79903
(Test in acc. to UL514B)
UL-approval for sizes M12x1,5 up to M25x1,5

Norm references:

- DIN EN ISO 14 159**
Safety of machinery - Hygiene requirements for the design of machinery
- DIN EN 1672-2**
Food processing machinery - Basic concepts – Part 2: Hygiene requirements



Suitable accessories:

SKINDICHT® SM CrNi M

Creator: MAU1/PDP Released: DAMU1/PDP	Document: DB53105300EN Version: 06	Page 1 of 2
--	---------------------------------------	-------------

53105300	DATA SHEET	
Valid from: 30.09.2024	SKINTOP® HYGIENIC SC	

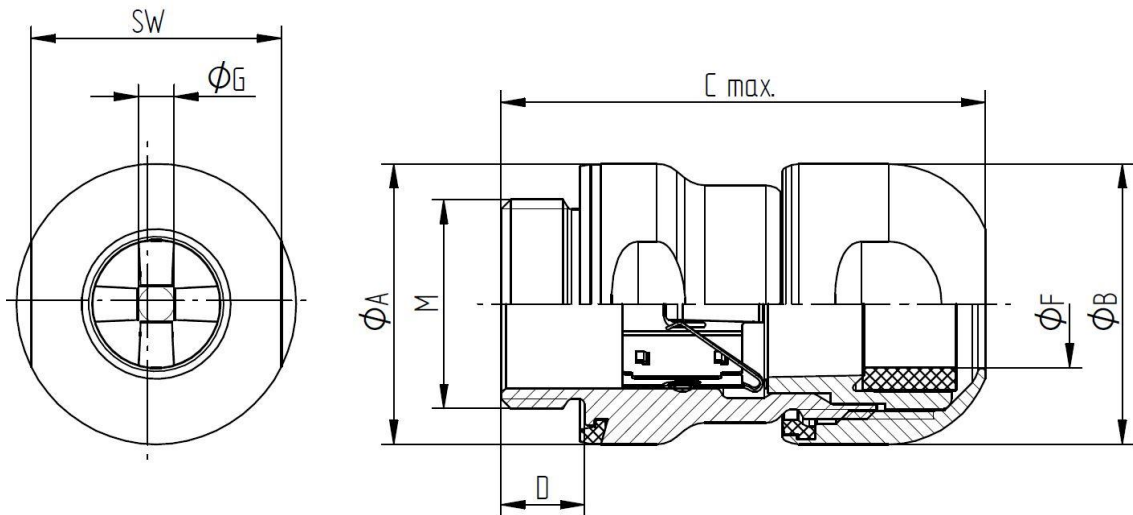

SKINTOP® HYGIENIC SC

Article number	Article description	M	SW [mm]	ϕA [mm]	ϕB [mm]	C max. [mm]	D [mm]	ϕF [mm] EN 62444 Clamping range	ϕF [mm] EHEDG Clamping range	ϕG min. [mm] Over braiding
53105300	SKINTOP HYGIENIC SC M12x1,5	M12x1,5	16	18,8	18,8	38,4	6,5	4,0 - 6,0	4,0 - 5,0	2
53105301	SKINTOP HYGIENIC SC M16x1,5	M16x1,5	20	22,8	22,8	41,4	7	6,5 - 9,0	6,5 - 8,0	4
53105302	SKINTOP HYGIENIC SC M20x1,5	M20x1,5	24	26,8	26,8	46,4	8	9,0 - 12,0	9,0 - 10,5	5
53105303	SKINTOP HYGIENIC SC M25x1,5	M25x1,5	29	31,8	31,8	48,9	8	11,5 - 15,5	11,5 - 14,0	7,5
53105314	SKINTOP HYGIENIC SC M32x1,5	M32x1,5	36	39,6	39	56	9	16,0 - 20,0	16,0 - 18,0	9
53105315	SKINTOP HYGIENIC SC M40x1,5	M40x1,5	45	49	49	62	9	22,0 - 27,0	22,0 - 24,0	15

For more information please see our current catalogue. Please do not hesitate to contact our laboratory if there are any questions regarding resistance against aggressive agents and special oil.

Creator: MAU1/PDP Released: DAMU1/PDP	Document: DB53105300EN Version: 06	Page 2 of 2
--	---------------------------------------	-------------