

53316220	DATA SHEET	
Valid from: 23.10.2024	SKINTOP® DIX-M	

The SKINTOP® DIX multiple seal insert with several holes makes it possible to pass several leads through a gland at the same time. Consequently components can be dimensioned smaller.

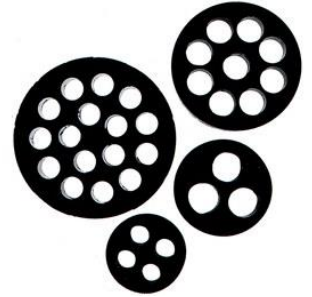

Technical features SKINTOP® DIX-M:

Material NBR
 Sizes M16 up to M50
 Temperature range -40 °C up to +100 °C
 Colour Black
 Protection class IP54 acc. to EN 60529
 IP68 - 5 bar, acc. to EN 60529
 (can be achieved if all the holes are optimally occupied)



Norm references:

Technical features SKINTOP® DIX-M FKM:

Material FKM
 Sizes M20, M40
 Temperature range -20 °C up to +200 °C
 Colour Green
 Protection class IP54 acc. to EN 60529
 IP68 - 5 bar, acc. to EN 60529
 (can be achieved if all the holes are optimally occupied)



Norm references:

Technical features SKINTOP® DIX-M SILICONE:

Material Silicone
 Sizes M16 bis M32
 Temperature range -50 °C up to +200 °C
 Colour Blue
 Protection class IP66 acc. to EN 60529
 IP68 - 10 bar, acc. to EN 60529
 (can be achieved if all the holes are optimally occupied)

Certificates



Norm references:

Creator: MAU1/PDP Released: DAMU1/PDP	Document: DB53316220EN Version: 09	Page 1 of 3
--	---------------------------------------	-------------

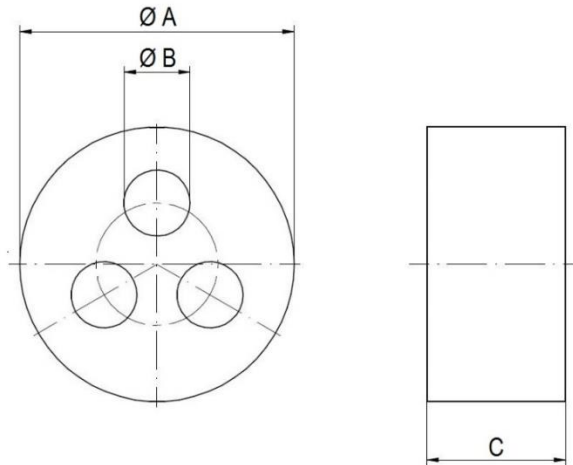

SKINTOP® DIX-M

Part No.	Size	Ø A mm	Ø B mm	Number of boreholes	C mm
53316220	M16	12,6	2	2	8,0
53316420	M16	12,6	2	4	8,0
53316230	M16	12,6	3	2	8,0
53316240	M16	12,6	4	2	8,0
53320250	M20	16,6	5	2	8,4
53320260	M20	16,6	6	2	8,4
53320340	M20	16,6	4	3	8,4
53320353	M20	16,6	5,3	3	8,4
53320440	M20	16,6	4	4	8,4
53320920	M20	16,6	2	9	8,4
53320430	M20	16,6	3	4	8,4
53325260	M25	20,8	6	2	9,5
53325250	M25	20,8	5	2	9,5
53325350	M25	20,8	5	3	9,5
53325360	M25	20,8	6	3	9,5
53325370	M25	20,8	7	3	9,5
53325450	M25	20,8	5	4	9,5
53325540	M25	20,8	4	5	9,5
53325640	M25	20,8	4	6	9,5
53332270	M32	25,6	7	2	12,0
53332280	M32	25,6	8	2	12,0
53332290	M32	25,6	9	2	12,0
53332370	M32	25,6	7	3	12,0
53332380	M32	25,6	8	3	12,0
53332460	M32	25,6	6	4	12,0
53332470	M32	25,6	7	4	12,0
53332560	M32	25,6	6	5	12,0
53332650	M32	25,6	5	6	12,0
53332840	M32	25,6	4	8	12,0
53332850	M32	25,6	5	8	12,0

53316220	DATA SHEET	
Valid from: 23.10.2024	SKINTOP® DIX-M	

Part No.	Size	Ø A mm	Ø B mm	Number of boreholes	C mm
53332940	M32	25,6	4	9	12,0
53340290	M40	33,8	9	2	14,5
53340310	M40	33,8	10	3	14,5
53340480	M40	33,8	8	4	14,5
53340490	M40	33,8	9	4	14,5
53340580	M40	33,8	8	5	14,5
53340590	M40	33,8	9	5	14,5
53340670	M40	33,8	7	6	14,5
53340860	M40	33,8	6	8	14,5
53340969	M40	33,8	6,9	9	14,5
53350118	M50	41,8	8	11	18,0
53350680	M50	41,8	8	6	18,0
53350780	M50	41,8	8	7	18,0
53350870	M50	41,8	7	8	18,0
53350147	M50	41,8	7	14	18,0
53350164	M50	41,8	4	16	18,0
53350166	M50	41,8	6	16	18,0

SKINTOP® DIX-M FKM

Part No.	Size	Ø A mm	Ø B mm	Number of boreholes	C mm
53420250	M20	16,6	5	2	8,4
53420260	M20	16,6	6	2	8,4
53440969	M40	33,8	6,9	9	14,5

SKINTOP® DIX-M SILICONE

Part No.	Size	Ø A mm	Ø B mm	Number of boreholes	C mm
5331 6300	M16	12,6	2	2	8
5331 6301	M16	12,6	3	2	8
5331 6302	M20	16,6	5	2	8,4
5331 6303	M20	16,6	6	2	8,4
5331 6304	M25	20,8	5	4	9,5
5331 6305	M25	20,8	6	2	9,5
5331 6306	M25	20,8	6	3	9,5
5331 6307	M25	20,8	7	3	9,5
5331 6308	M32	25,6	7	4	12

For more information, please see our current catalogue. Please do not hesitate to contact our laboratory if there are any questions regarding resistance against aggressive agents and special oil.

Creator: MAU1/PDP Released: DAMU1/PDP	Document: DB53316220EN Version: 09	Page 3 of 3
--	---------------------------------------	-------------